

# Radio-Electronics®

60c ■ JULY 1973

FOR MEN WITH IDEAS IN ELECTRONICS

## BUILD THIS IC FUNCTION GENERATOR Get 6 Basic Modulated Waveforms

8 WAYS TO TEST  
Hi-Fi Amplifiers

CALCULATOR WITH A MEMORY  
That You Build From A Kit

AMPLIFIER STRAPPING  
4 Channel — 2 Channel

BOOLEAN ALGEBRA  
Logic Circuit Math

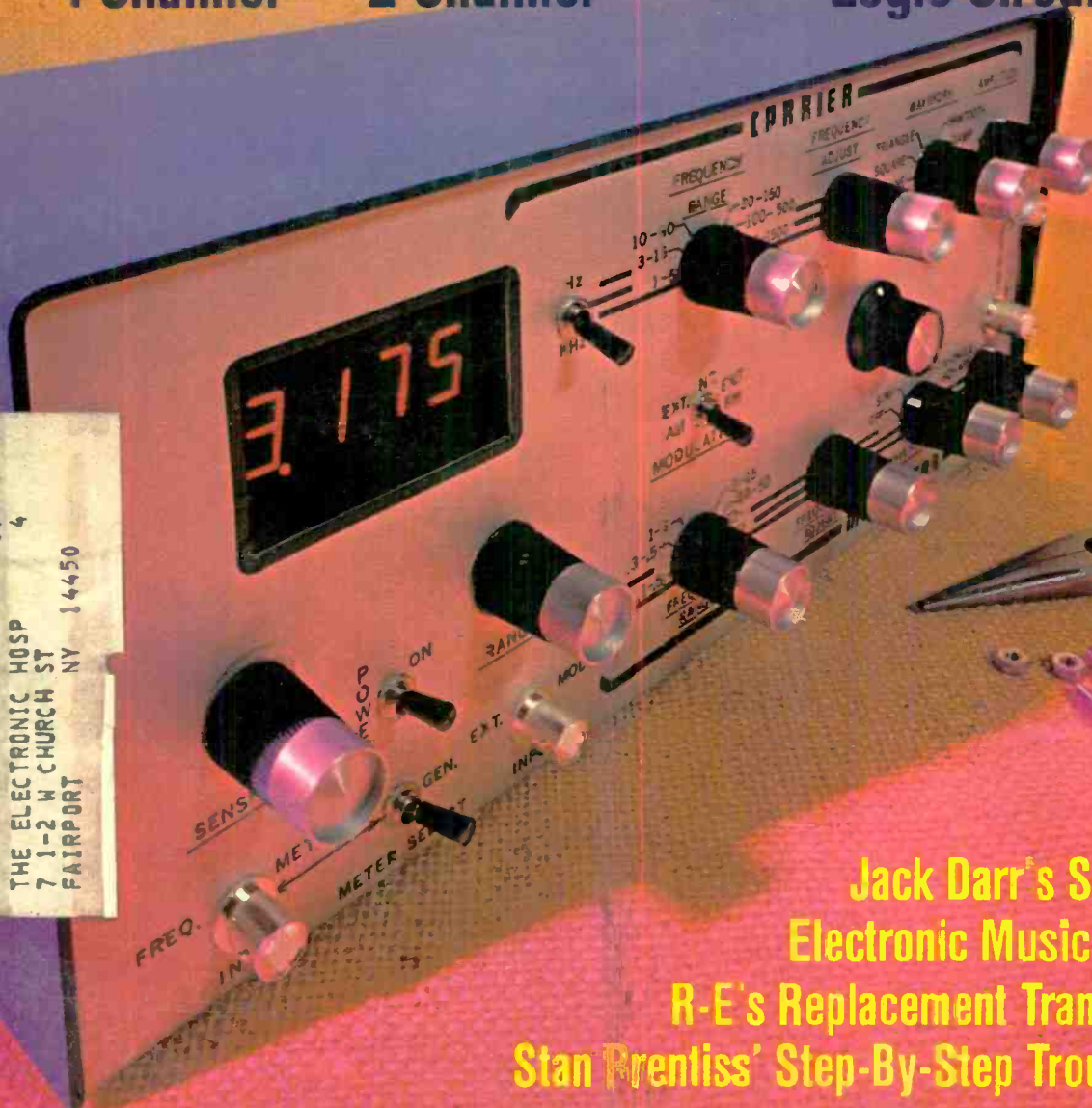

A  
GERNSBACK  
PUBLICATION

**PLUS**

Jack Darr's Service Clinic  
Electronic Music Synthesizer  
R-E's Replacement Transistor Guide  
Stan Prentiss' Step-By-Step Troubleshooting

386164 000 71TEEL96 JUL73 0 A  
07 4  
THE ELECTRONIC HOSP  
7 1-2 W CHURCH ST  
FAIRPORT NY 14450

# Here's everything you'd expect from a high-priced portable multimeter.

## Except a high price.

The B & K Solid-State Electronic Multimeter (Model 277) has 8 important features that you can get on most other quality-made units, but not at prices like ours.

You'd expect to pay quite a lot for a multimeter featuring both high and low power ohms ranges. Both are critically necessary. The B & K 277, with its .068 V power source on low power ohms, will always read the true value of a resistor shunted by a semi-conductor without concern for the semi-conductor's presence. A con-

ventional ohmmeter with a 1.5 volt supply could cause a shunt semi-conductor to conduct, giving a false resistance reading.

The 277's high-power resistance ranges are useful in determining whether transistors are good or bad simply by first forward biasing them to make them conduct and then reversing the leads to qualify the front-to-back ratio.

The B & K 277 has so many features you wouldn't expect at the price: like a .1 V low-voltage scale for both AC and DC; a DC current range of

1  $\mu$  A full-scale for testing sensitive semi-conductor leakage; the unit is fully protected from overloads by fuse; input impedance of 15 M  $\Omega$  on DC; 1% precision resistors; a 4 1/2 inch, 50  $\mu$  A mirrored scale meter; frequency response to 150 KHz and 59 individual ranges.

Our price alone doesn't make it a value, but our features at our price make it a fantastic value.

# \$99.95



**B&K** Very good equipment at a very good price.

Product of Dynascan Corporation/1801 W. Belle Plaine Ave., Chicago, Ill. 60613

Circle 30 on reader service card

www.americanradiohistory.com

# 14 ways to help you earn more money

Take one of these 14 Career Guidance Booklets and "Demonstration Lessons"—free—and find out how you can now start developing the skills you need to succeed in a better-paying career.

In today's fast-moving world, you can move up to a better-paying career in less time than you may think. If you choose a career field that's right for you. And if you can get the kind of career training that today's employers are willing to pay big money for.

To help you choose the right career field, we have listed 14 opportunities in the coupon below. You are invited to discover everything you want to know about the field you like best, by simply mailing the coupon below for a free Career Guidance Booklet.

Your free booklet will describe the opportunities, income and job security you might expect in your newly chosen field. It will also explain how ICS can help you prepare for this—in your spare time...in your own home...regardless of your past experience.

In addition, you'll receive a free "Demonstration Lesson" that lets you see for yourself why you can prepare for your new career—the ICS way—in much less time than you may think.

## Major corporations use ICS career training

Please bear in mind, as you fill in the coupon below, that more than 8,500,000 men and women have turned to ICS for career training, since 1890.

Some 3,300 American firms and government agencies are also using ICS training programs to upgrade and update their employees. Among these firms are such names as Ford, U.S. Steel, Chrysler, Mobil, DuPont, ITT, IBM, General Motors, 3M Company, Alcoa, Pan Am, GE, Motorola, and RCA.

ICS career training is Approved for Veterans, and is Accredited by the Accrediting Commission of the National Home Study Council. Now it's *your* turn to discover how ICS can start *you* in a rewarding new career. Just fill in the coupon below and mail today.



## Take one of these Career Guidance Booklets — free!

**ICS** International Correspondence Schools  
Scranton, Pennsylvania 18515

Please send me free booklets and a free "Demonstration Lesson" for the field I have checked below. I understand that I am under no obligation.

### 1. ACCOUNTING

- Business Accounting
- Bookkeeping
- CPA Training
- Income Tax Specialist

### 2. BUSINESS MANAGEMENT

- Business Administration
- Executive Management
- Industrial/Production Management
- Marketing/Advertising/Sales Management

### 3. COMPUTER PROGRAMMING

- Programming Concepts
- COBOL  System 360
- Fortran IV

### 4. SECRETARIAL

- Medical
- Legal
- Executive

### 5. MOTEL/HOTEL MANAGEMENT

- Motel Management
- Club/Restaurant Management
- Resort Manager
- Hotel Executive

### 6. INTERIOR DECORATING & DESIGN

- Interior Decorator
- Interior Designer
- Advanced Interior Designer

### 7. ELECTRICIAN

- Master Electrician
- Practical Electrician

### 8. DRAFTING

- General Drafting
- Specialized Training (Arch., Mech., Struct., Electrical, Aircraft, Electronics)

### 9. AUTOMOTIVE

- Master Mechanic
- Air Conditioning Specialist
- Body Rebuilding Specialist
- Diesel/Gas Mechanic

### 10. ENGINEERING

- Mechanical  Civil
- Chemical  Industrial
- Electrical-Electronics
- Surveying & Mapping

### 11. AIRLINE/TRAVEL

- Reservation and Communication Specialists
- Ticket Agent
- Travel Agent

### 12. ELECTRONICS

- Electronics Technician
- Specialized programs in Computer Servicing, Communications, CATV
- FCC Licensing

### 13. TV SERVICING

- Color TV Technician
- Stereo/Hi-Fi Specialist
- CATV/MATV Specialist

### 14. AIR CONDITIONING/HEATING

- Air Conditioning/Refrigeration Technician
- Heating Specialist

HIGH SCHOOL. (Earn a H. S. Diploma.)

Check here for special information, if age 16 or under.

Miss \_\_\_\_\_ XA634W  
Mrs. \_\_\_\_\_  
Mr. \_\_\_\_\_ Age \_\_\_\_\_

Address \_\_\_\_\_ Apt. \_\_\_\_\_

City \_\_\_\_\_

State \_\_\_\_\_ Zip \_\_\_\_\_

Approved for Veterans' Training. Eligible Institution under the Guaranteed Student Loan Program. Accredited Member National Home Study Council. Canadian residents use coupon address for service from ICS Canadian, Ltd. In Hawaii: 931 University Ave., Honolulu, Hawaii 96814



# This tube has a 1-Year Warranty. This tube has a 2-Year Warranty. This tube has a 3-Year Warranty.

## The choice is up to you.

Now, you're the one to decide the best type of customer warranty for Sylvania Color Bright 85<sup>®</sup> replacement tubes.

The one-year warranty is basic. GTE Sylvania gives you that.

But, through your distributor, you can offer a 2- or 3-year warranty for just a little extra cost.

No matter which warranty you offer, it's backed up all the way.

The whole idea of this program is to give you

and your customers an added incentive for using Color Bright 85 replacement tubes.

Now, you can offer your customer the warranty that suits both of you best.

Or better yet, you can offer him all three.

Talk to your GTE Sylvania distributor to get full details.

Sylvania Electronic Components, 100 First Ave., Waltham, Mass. 02154

**GTE SYLVANIA**

# Radio-Electronics

FOR MEN WITH IDEAS IN ELECTRONICS

More than 65 years of electronics publishing

JULY 1973

## COMPUTERS AND CALCULATORS

- 23 **Boolean Algebra**  
The secrets of logic circuit math, made easy.  
*by James F. Kennedy*
- 55 **Desktop Calculator Built From A Kit**  
Inside a modern kit-built calculator. *by James R. Kellahin*

## BUILD ONE OF THESE

- 41 **IC Function Generator**  
Get 6 basic modulated waveforms. 30 different variations in all. *by Jack Cazes*
- 46 **Electronic Music Synthesizer**  
Part III—Details of keyboard construction.  
*by James F. Simonton, Jr.*

## HIGH-FIDELITY STEREO

- 32 **Amplifier Strapping**  
Built-in switching converts 4-channel amplifiers for 2-channel playback, and it isn't easy. *by Len Feldman*
- 37 **8 Ways To Test Hi-Fi Amplifiers**  
How to test for rms power output vs. distortion; harmonic distortion vs. output voltage; output vs. IM distortion; power bandwidth; sensitivity; damping factor; signal-to-noise ratio; and frequency response.  
*by Edward C. Palmer*

## TELEVISION

- 36 **Equipment Report**  
Lesco Multitracer
- 48 **Troubleshooting Logically**  
Part IV—Final review and a test to see if you've learned how. *by Jon Turino*
- 50 **Step-By-Step Troubleshooting**  
Solid-state vertical sweep circuits. *by Stan Prentiss*
- 58 **Service Clinic**  
IC's, test methods and equipment. *by Jack Darr*
- 59 **Reader Questions**  
R-E's Service Editor solves reader problems.

## GENERAL ELECTRONICS

- 4 **Looking Ahead**  
Tomorrow's news today. *by David Lachenbruch*
- 36 **Equipment Report**  
Kandu PC Kit.
- 52 **R-E's Replacement Transistor Guide**  
Part V—220 more types are listed. 2N959 to 2N1201.  
*by Robert & Elizabeth Scott*
- 69 **Equipment Report**  
RCA WV-529A vom
- 76 **LED Panel Lights**  
Use an LED to replace a conventional pilot lamp.  
*by William D. Kraengel, Jr.*
- 84 **Appliance Clinic**  
Reversing motors, yesterday and today. *by Jack Darr*

## DEPARTMENTS

- |                           |                               |
|---------------------------|-------------------------------|
| 16 <b>Letters</b>         | 90 <b>Noteworthy Circuits</b> |
| 6 <b>New &amp; Timely</b> | 70 <b>Next Month</b>          |
| 71 <b>New Books</b>       | 99 <b>Reader Service Card</b> |
| 82 <b>New Literature</b>  | 86 <b>Technotes</b>           |
| 78 <b>New Products</b>    | 88 <b>Try This</b>            |

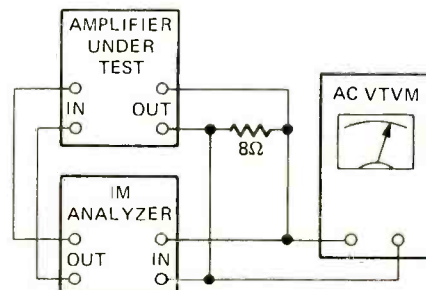

TESTING HI-FI AMPLIFIERS? Here's one of the eight tests you should be making.

... see page 37

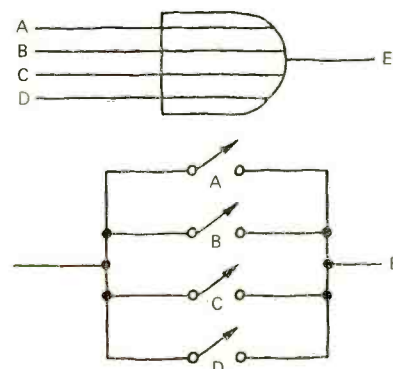

UNDERSTANDING BOOLEAN ALGEBRA is the secret that teaches how logic circuits operate. Find out for yourself.

... turn to page 23

Hugo Gernsback (1884-1967)  
founder

M. Harvey Gernsback, editor-in-chief  
and publisher

Larry Steckler, CET, editor

Robert F. Scott, W2PWG CET, technical editor

Jack Darr, CET, service editor

Louis E. Garner, Jr., semiconductor editor

I. Queen, editorial associate

Leonard Feldman, contributing high-fidelity editor

David Lachenbruch, contributing editor

Vincent P. Cicenla, production manager

Sarah Martin, production assistant

H. Matysko, circulation

Cover photograph by Walter Herstatt

Cover design by Louis E. Rubsamen

Radio-Electronics is indexed in *Applied Science & Technology Index* and *Readers Guide to Periodical Literature*.



Radio-Electronics, July 1973, Vol. 44, No. 7. Published monthly by Gernsback Publications, Inc., 200 Park Avenue South, New York City 10003. Second-class postage paid at New York, N.Y. and additional mailing office. One-year subscription rate: U.S.A. U.S. possessions and Canada, \$7. Pan-American countries, \$8. Other countries, \$8.50. Single copies 60¢. © 1973 by Gernsback Publications, Inc. All rights reserved. Printed in U.S.A.

**Subscription Service:** Mail all subscription orders, changes, correspondence and Postmaster Notices of undelivered copies (Form 3579) to Radio-Electronics Subscription Service, Boulder, Colo. 80302.

A stamped self-addressed envelope must accompany all submitted manuscripts and/or artwork or photographs if their return is desired should they be rejected. We disclaim any responsibility for the loss or damage of manuscripts and/or artwork or photographs while in our possession or otherwise.

As a service to readers, Radio-Electronics publishes available plans or information relating to newsworthy products, techniques and scientific and technological developments. Because of possible variances in the quality and condition of materials and workmanship used by readers, Radio-Electronics disclaims any responsibility for the safe and proper functioning of reader-built projects based upon or from plans or information published in this magazine.

# looking ahead

*Dave Lachenbruch is currently touring Europe and will be travelling through Europe for the next several months. Each issue, a portion of his Looking Ahead column will be devoted to activities he notes and feels are of interest to our readers. The remainder of his column will concentrate on the latest developments in electronics in the United States.*

## Components show

Paris, France—What is claimed to be the world's largest electronic components show attracted the astonishing total of 50,000 visitors to tour nearly 900 exhibits. Although very little was shown which has not previously been announced, unquestionably the three items of principal interest were monolithic IC's for consumer applications (principally color TV), semiconductor memory devices and opto-electronics. In the latter area, the spotlight was shared by optical fibers capable of extremely low loss and liquid crystals.

Not surprisingly, many of the components seem destined eventually for the consumer market—liquid-crystal displays were shown in mock-up wristwatches, for example. The European consumer electronics market is in the midst of an unprecedented boom, highlighted by a television market in which as many as 7 million color and 9 million black-and-white sets could be sold this year. While not equalling the performance of TV in the United States (8.8 million color and 8.2 million monochrome sets sold last year), the figures are astonishing in view of the cost of

color sets in Europe—\$650 to \$1,000 for a deluxe table model, depending on country.

## Standards headaches

Suppose you live on a border, or in a small country, where you can pick up several varieties of TV channels—say, for example, Britain's 405-line and France's 819-line black-and-white, plus 625-line black-and-white with both negative and positive video modulation, as well as 625-line color in both PAL and SECAM systems. If you want to receive all available programs you need an electronic computer—and that's exactly what you get in a combination set. One Belgian firm offers set manufacturers a complete color TV kit to build a ten-module set which can receive all European color and monochrome broadcasts. Sensing the incoming signal, it automatically decodes whatever is being received. Needless to say, most manufacturers buy the kit rather than design their own sets for these peculiar multi-standard areas.

## Kodak's videoplayer

Eastman Kodak has joined the U.S. videoplayer race with an announcement that it will market by the end of this year an attachment for playing super 8 film in color and sound (using international magnetic sound film standards) on conventional color sets. Designed initially for education, business and industry, the Kodak Supermatic uses standard super 8 cartridges—the same type used in automatic projectors.

For several years, Kodak has been attempting to persuade electronics manufacturers that the future of the videoplayer could well be in

standard Super-8 film. Its main arguments have been that film already is an existing standard, that (unlike magnetic tape or discs) it can be used with any TV system. Any existing Super-8 film—educational or even home movies—can be played through a TV set using the Kodak system.

Initial retail price of the compact Supermatic TV attachment will be \$1,250—above the area of home mass marketing. Future models, however, could be aimed at the home-movie crowd. Meanwhile, in Paris, the French electronics producer, Thomson-CSF, announced that it would produce a version of Supermatic for European television standards.

## 110° color tubes

The latest rage in European TV receivers is the 110° wide-angle picture tube, which makes possible a much slimmer cabinet. Since almost all sets sold in Europe are table models, this has become a real selling-point—a table model which will actually fit on a table. Some manufacturers now say that solid-state componentry and simplified circuits have made 110° sets actually as inexpensive to produce as 90° hybrid models.

Two basically different approaches to 110° design are now being offered to European TV manufacturers by the various tube suppliers. The most prevalent is the conventional wide-neck design, developed by the huge Netherlands-based electrical-electronics combine, Philips. An alternative was developed by RCA, which is a partner in two European picture tube-producing companies. This uses a narrow-neck tube, which requires less voltage for deflection, and a simple toroidal yoke with few con-

vergence adjustments and requiring no active components for convergence.

The narrow-neck approach made possible large savings in set manufacture—until Philips came out with new circuitry and a new saddle yoke which appear to offer the same advantages as the narrow-neck, and which Philips says is now cheaper. When and if the American television industry adopts 110° picture tubes, the same battle is likely to break out at home. At present, the only American manufacturer offering a 110° color set is RCA (with a 19-incher—narrow-neck, of course), although Japanese wide-neck versions are available.

## Home videoplayers

Whether the videoplayer is currently a viable home product has yet to be determined. The negative aspect was underscored when it was revealed that the first manufacturer of color VTR's exclusively for consumer use, Cartridge Television, Inc., had suspended production last December after producing only 6,000 decks. It could, of course, resume as demand warrants. In the Netherlands, on the other hand, Philips, which has produced about 20,000 of its VCR video-cassette recorders to date, says that in some European countries, up to 90% of those sold are installed in homes, despite the fact that the device is designed for educational and commercial use, and even though no pre-recorded entertainment programming is available. People use the machine, Philips says, for recording TV shows off the air (with an automatic clock-timer) for later viewing.

by **DAVID LACHENBRUCH**  
CONTRIBUTING EDITOR

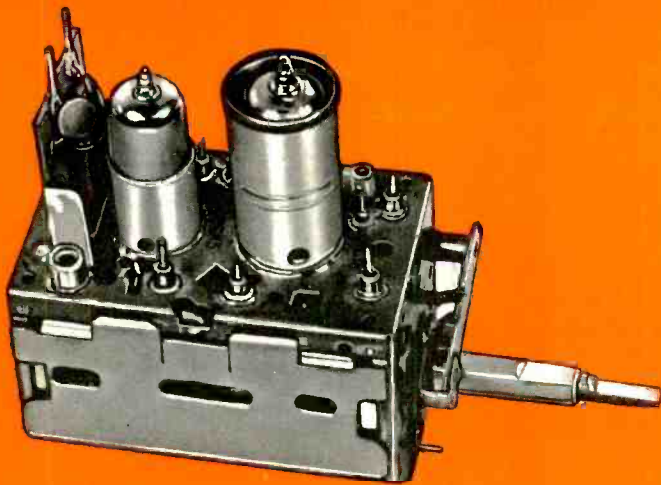

# \$9.75

**ALL PARTS INCLUDED**

except tubes and transistors

**ONE YEAR GUARANTEE**

## TUNER SERVICE CORPORATION

**PROVIDES YOU WITH A COMPLETE SERVICE FOR ALL YOUR TELEVISION TUNER REQUIREMENTS.**

### REPAIR

VHF Or UHF Any Type \$9.75.  
UHF/VHF Combo \$15.00.

In this price all parts are included. Tubes, transistors, diodes, and nuvistors are charged extra.

Fast efficient service at our conveniently located service centers. This price does not cover mutilated tuners.

All tuners are cleaned ultrasonically, repaired, realigned and air tested.

### REPLACE

Universal Replacement Tuner \$9.75.

This price buys you a complete new tuner built specifically by SARKES TARZIAN INC. for this purpose.

All shafts have a maximum length of 10" which can be cut to 1½".

Specify heater type parallel and series 450mA or 600mA.

### CUSTOMIZE

Customized tuners are available at a cost of only \$15.95. (With trade-in \$12.95)

Send in your original tuner for comparison purposes to:



WATCH US GROW

## TUNER SERVICE CORPORATION FACTORY-SUPERVISED TUNER SERVICE

Backed by the largest tuner manufacturer in the U.S.—SARKES TARZIAN, Inc.

HEADQUARTERS	537 SOUTH WALNUT ST., Bloomington, Indiana 47401	TEL: 812-332-7251
ARIZONA	2629 NORTH FIRST AVE., Tucson, Arizona 85717	TEL: 602-791-9243
CALIFORNIA	1324 MARSTEN ROAD, Burlingame, California 94010	TEL: 415-347-5728
CALIFORNIA	123 PHOENIX AVE., Modesto, California 95351	TEL: 209-521-8051
CALIFORNIA	SARKES TARZIAN, Inc. TUNER SERVICE DIVISION 10654 MAGNOLIA BLVD., North Hollywood, Calif. 91601	TEL: 213-769-2720
FLORIDA	1505 CYPRESS ST., Tampa, Florida 33606	TEL: 813-253-0324
GEORGIA	938 GORDON ST., S. W., Atlanta, Georgia 30310	TEL: 404-758-2232
INDIANA	817 N. PENNSYLVANIA ST., Indianapolis, Ind. 46204	TEL: 317-632-3493
INDIANA	6833 GRAND AVE., Hammond, Indiana 46323	TEL: 219-845-2676
KENTUCKY	2920 TAYLOR BLVD., Louisville, Kentucky 40208	TEL: 502-634-3334
NEW JERSEY	547-49 TONNELE AVE., Jersey City, New Jersey 07307	TEL: 201-792-3730
	(On U. S. Highway 1 & 9)	
OHIO	4597 PEARL ROAD, Cleveland, Ohio 44109	TEL: 216-741-2314
OREGON	1732 N.W. 25th AVE., Portland, Oregon 97210	TEL: 503-222-9059
TENNESSEE	1215 SNAPPS FERRY RD., Greeneville, Tennessee 37743	TEL: 615-639-8451
TENNESSEE	1703 LAMAR AVE., Memphis, Tennessee 38114	TEL: 901-278-4484
TEXAS	11540 GARLAND RD., Dallas, Texas 75228	TEL: 214-327-8413
VIRGINIA	4538 PRINCESS ANN ROAD, Norfolk, Virginia 23502	TEL: 703-855-2518

Circle 2 on reader service card

# new & timely

## Human hand is key in new electronic lock

A new electronic identification system, which can be used to permit or deny access to buildings, computers, restricted areas, and for other purposes where automatic and absolute identification is desired, is being produced by Identimation Marketing Corp. of Northvale, N.J.

The system measures hand geometry with a pair of optical scanners and compares it with the information on a magnetic card previously encoded with a 12-digit numerical code for the same hand. The length of the fingers in hundredths of an inch, the translucency of the skin between the fingers, the curvature at the tips of the fingers and the deformation of the skin as pressure is



THE IDENTIMAT is a desk-mounted device that measures 13 x 19 x 19 inches, works unattended. It compares the information from the hand with that on the magnetic identity card, which is seen at lower right in the photograph.

applied are all measured and compared with the information on the card in a simplified computer (if the company or institution using the device has a computer, it can be used). If identity is proved, doors are unlocked, time clocks are energized, access to computers permitted, or other desired effects are produced.

More effective and secure than common identity cards, this device works only when the card and the legitimate holder are both present. A lost or stolen card is no use to the finder or thief.

An especially important application is in employee time-clocks. A friend cannot "punch-in" the employee—he has to be there himself. Identimation Corp. has taken advantage of this feature to put out a complete automated payroll system, which first assures that only authorized employees obtain access to the plant, identifies each employee and records his time in and time out, and prints payroll checks automatically. It can at any time make up reports showing not only the overall payroll situation at the instant, but select out such items as amount of overtime, absentees on a given day by name and department, the various withholding or other desired information.

## Five thousand technicians have CET certification

The Executive Director of the International Society of Certified Electronic Technicians, Ron Crow, reported last March that the electronic technicians who had successfully passed the written CET examination totalled 4,875. With the Society's normal rate of growth, this means that the number of CET's is now well over 5,000.

At the time of the survey, 4,551 were certified for radio-TV and consumer electronics and 44 had qualified as industrial CET's. The rest were on the Associate level. Associates have met all the requirements of the Society, have passed the basics portion of the exam and have completed a formal electronics course, but have not acquired the four years of experience necessary to become a full-fledged CET.

The Indianapolis office, which processes the tests, finds that 54 per cent of the technicians taking the examination are successful. Most of those who fail try again, and at the time of the report, nearly one-third of the examinations were retakes. In Oregon, where it is necessary to pass the CET examination to obtain a permanent state license, the figure rises to 44 per cent.

There are now CET's in all 50 states and in a dozen foreign countries, including such far-away places as Uruguay and Turkey. California leads in number of registered CET's with 1132.

Mr. Crow expects NEA and ISCET to begin a public information program in the very near future to educate the set owner as to the advantages of using a CET for electronic service. With 5000 CET's registered there is a wide enough distribution, he says, that CET can be meaningful to the entire industry and the public.



NEW STAMP COMMEMORATES the invention of the transistor at Bell Labs 25 years ago. Behind the enlarged replica of one of the modern packaged circuits made possible by the transistor are, left to right, Walter Brattain, William Shockley and John Bardeen. In front is Edward Dorsey of the N.Y. Post Office. The unveiling occurred at the IEEE Convention, and the stamp is one of a series of four being issued July 10 to honor progress in electronics.

## "Handie" unit makes user part of telephone system

A new hand-held portable telephone unit that will permit its user to place or receive calls from almost anywhere in a metropolitan area equipped with what Motorola calls the DYNA T.A.C. system was demonstrated recently in New York City. According to Motorola vice president John Mitchell: "In a city where the DYNA T.A.C. system is installed, one can make calls while riding in a taxi, walking down the street or sitting in a restaurant, to any conventional telephone in the world."

The DYNA T.A.C. system will consist of a number of receiver-transmitter combinations placed strategically throughout the city in which the system is installed. These are linked to a central computer, which controls the city system and connects the phones to the regular telephone network.

To make a call, the user presses a "receiver-off-hook" button and waits for

(continued on page 12)



# *All quadraphonic systems are not created equal... Sansui has created the QS vario matrix.*

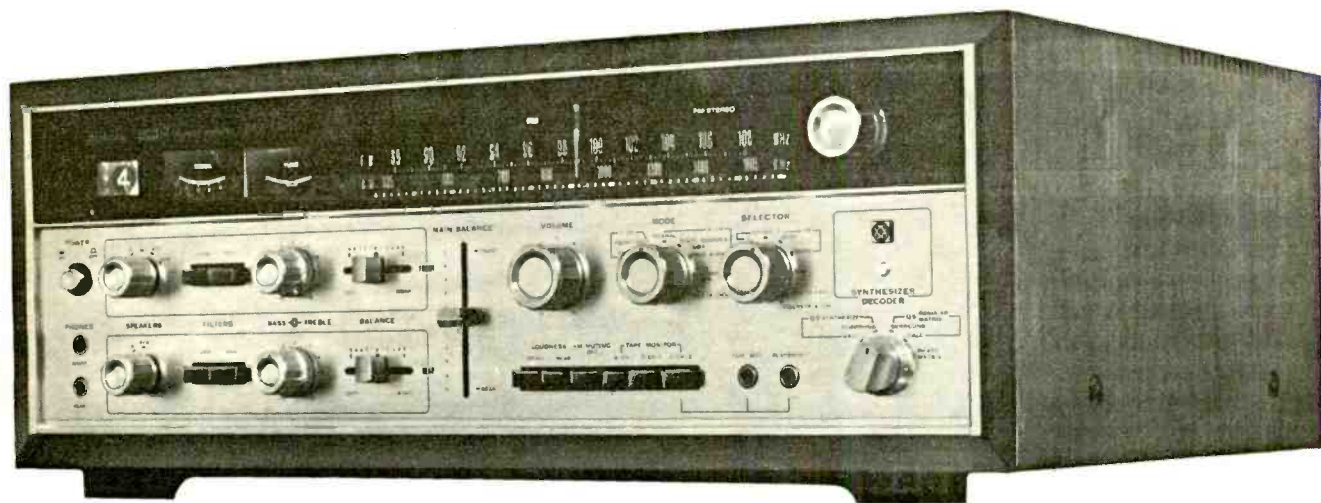

**QRX-6500**

Here at last is the development that once and for all will lay to rest the dispute over discrete vs. encoded recordings. The Sansui vario matrix—a technological extension of the QS Regular Matrix—provides unbelievable front-to-back separation, to a degree never before possible with matrix recordings—separation so great that engineers have hailed it as the “discrete matrix.”

Two new units in the Sansui four-channel lineup—the QRX-6500 and the QRX-3500 contain this outstanding new decoder. These full-featured four-channel receivers have high power output (280 watts and 180 watts IHF), superb FM sensitivity, and are loaded with special features to make quadraphonic listening a totally trouble-free and fulfilling experience.

The new decoder includes a position for Phase Matrix recordings, and both “Hall” and “Surround” positions for the QS Regular Matrix and for the synthesizer section, for accurate decoding of any current matrix as well as creating enhanced 4-channel sound from two-channel recordings.

Other special features include a sound-field rotation switch, linear balance controls for front/rear and for left/right, and the capability to drive up to 10 speakers—all front-panel switch-selected.

Treat your ears to a demonstration today at your nearest Sansui dealer. Your listening will never be the same again.



**QRX-3500**



## **SANSUI ELECTRONICS CORP.**

Woodside, New York 11377 • Gardena, California 90247

ELECTRONIC DISTRIBUTORS, Canada,

SANSUI ELECTRIC CO., LTD., Tokyo, Japan • Sansui Audio Europe S. A., Antwerp, Belgium

# NOW you can train at home building a NEW 25" DIAGONAL Solid State Color TV engineered by NRI for learning and trouble-shooting

*So much better for learning TV servicing than any hobby kit, because NRI designed and created it as an educational tool.*

Unlike hobby kits which are designed for creating a TV set as the end product, NRI built its exclusive 25" Diagonal Solid State Color TV kit as a real training kit. You can introduce and correct defects . . . for trouble-shooting and hands-on experience in circuitry and servicing. The kits include a wide-band oscilloscope, color bar crosshatch generator, transistorized volt-ohmmeter and other valuable equipment that can soon have you earning \$5 to \$7 an hour servicing color sets in your spare time.

Handsome woodgrain cabinet, at no extra cost. (Offered only by NRI)

New square-cornered Sylvania picture tube

100% solid state chassis

6-position detented UHF channel selector



Modular construction with plug-in circuit boards

Automatic degaussing

Automatic fine tuning

Automatic color control

Automatic tint control

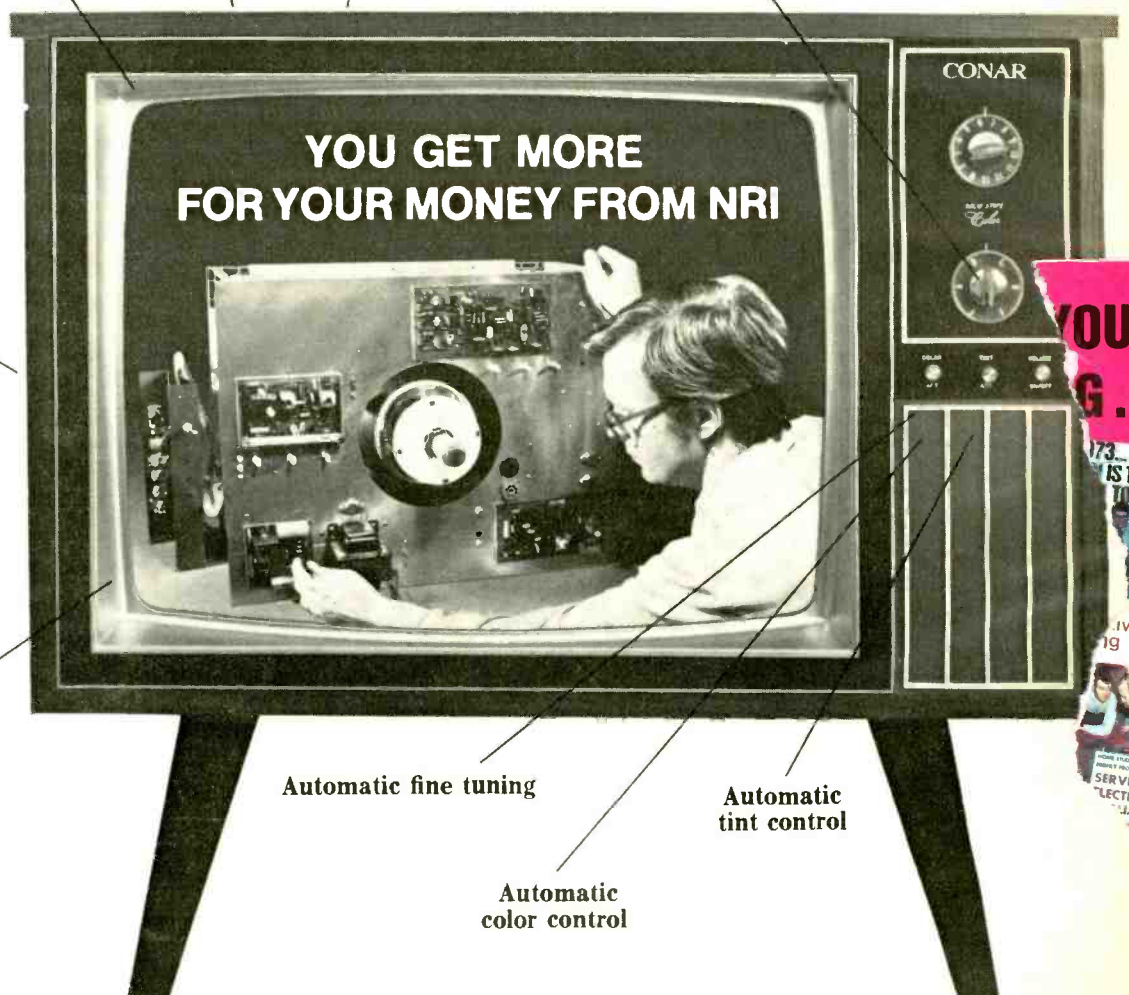

# NRI FIRSTS make learning Electronics fast and fascinating—to give you priceless confidence

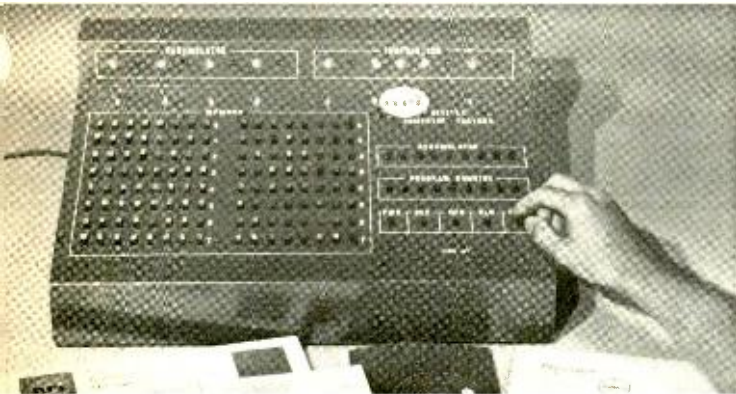

**FIRST** to give you a complete programmable digital computer, with memory, you build yourself . . . to learn organization, operation, trouble-shooting and programming. This remarkable computer is one of ten training kits you receive with the new NRI Complete Computer Electronics Course.

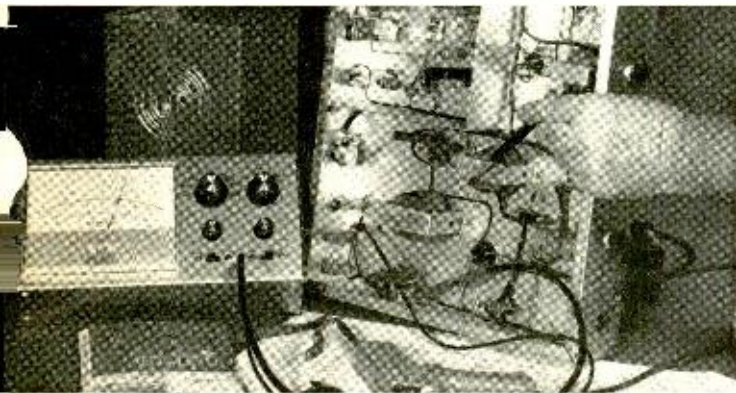

**FIRST** to give you true-to-life experiences as a Communications Technician. Every fascinating step you take in NRI Communications training, including circuit analysis of your own 15-watt, phone/cw transmitter, is engineered to help you prove theory and later apply it on the job. Studio equipment operation and trouble shooting become a matter of easily remembered logic.



**FIRST** to give you completely specialized training kits engineered for business, industrial and military Electronics Technology. Shown is your own training center in solid-state motor control and analog computer servo-mechanisms. Telemetry circuits, solid-state multivibrators and the latest types of integrated circuits are included in your course.

The NRI color TV and digital computer kits are the latest in a long line of "firsts" for NRI. For more than fifty years, NRI has been providing unique 3-dimensional home-study training that has helped hundreds of thousands of students reach their goals quickly and easily.

What NRI provides is a combination of kits and bite-size texts that give you hands-on experience while you are learning. The texts average only 40 pages each, and they are fully illustrated. You are taken step-by-step from the first stages into the more advanced theory and techniques . . . with an expert instructor ready at all times to provide valuable guidance and personal attention. (The level of personal attention provided is more than you would receive in many classrooms.) Once you've grasped the fundamentals, you move with confidence and enthusiasm into new discoveries in the fascinating world of electronics.

You start out with NRI's exclusive Achievement Kit, containing everything you need to get moving fast. Lessons have been specifically written so that experiments build upon one another like stepping stones. You can perform a hundred experiments, build hundreds of circuits . . . as you learn to use the professional test equipment provided, building radios and TV sets, transmitter or computer circuits. It's the priceless "third dimension" in NRI training . . . practical experience.

## Train with the leader—NRI

Compare training kits, texts, techniques and overall training . . . and you'll find that you get more for your money from NRI. Whatever your reason for wanting more knowledge of Electronics, NRI has an instruction plan that will meet your needs. Choose from major programs in Advanced Color TV Servicing, Complete Computer Electronics, Industrial Electronics and the other special courses designed to meet specific needs. With NRI home training, you can learn new skills while you're still working at your present job . . . and turn yourself into the man in demand.

### GET FACTS ABOUT GI BILL

If you have served since January 31, 1955, or are in service now, check GI line on postage-free card.

## Send for free NRI catalog

MAIL THE POSTAGE-FREE CARD FOR THE FREE NRI CATALOG IN THE FIELD OF YOUR CHOICE. YOU WILL BE UNDER NO OBLIGATION. NO SALESMAN WILL CALL.

If the card has been used, write direct to:



**NRI TRAINING**

3939 Wisconsin Ave.  
Washington, D.C. 20016

a dial tone. He then dials the number he wants on the Touch-Tone dial with which the units are equipped. His signals are picked up by the nearest receiver and relayed by its transmitter to the central computer, which completes the connection to the conventional telephone system.

To reach a portable unit, the caller simply dials its number as he would any other. A bell on the portable unit rings, the recipient presses his "off-the-hook" button and is ready to listen and talk.

As soon as FCC approval is obtained, Motorola expects to set up the first system, in New York City. Plans are to have it working before 1976. The FCC has proposed allocating to two-way radio that portion of the uhf spectrum now occupied by television channels 73 to 83, and has encouraged the industry to come forward with new two-way uses for the spectrum. Motorola's new portable radiophone is a response to that invitation.

### New electronic speedometer uses integrated circuit

A new shirt-button size speedometer for automobiles is expected to do away with the problems of wear and tear that create maintenance problems in the conventional speedometer. Introduced by Intermetall, German subsidiary of ITT, the new device will—the manufacturer believes—be able to match the price of mechanical systems while eliminating their drawbacks.

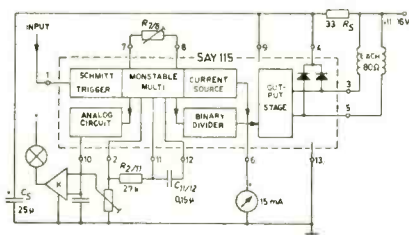

Diagram of a Speedometer Circuit with full deflection at F: 300 Hz

**THE SPEEDOMETER CIRCUIT INCLUDES a Schmitt trigger, a monostable multivibrator, a current source for feeding the moving-coil meter, analog output, and binary frequency divider followed by a power output that feeds the two coils of the mileage indicator motor.**

Built around the ITT monolithic integrated circuit SAY 115, the unit indicates both speed and mileage, and can even be arranged to trigger an alarm if speed is excessive.



"FAR FROM HIS PHONE AND KINDRED," this Intrepid raftsmen-fisherman is part of the telephone network as long as he is in range of one of the DYNA T.A.C. transmitters.

### Commerce Dept. turns off porpoise guides to tuna

Tuna fishermen will no longer be able to depend on man's intelligent friend the porpoise to radio news of schools of tuna to them. The Commerce Department's National Oceanic and Atmosphere Administration has prohibited the use of porpoise-back transmitters for that purpose.

Porpoises tend to swim above schools of tuna, rising frequently to the surface to breathe. When their antennas are above the water, their signals can reach fishermen's receivers within a 15-mile range.

Newspaper reports did not state whether the action was a humane measure taken on behalf of the porpoises, or a conservation measure aimed at protecting the tuna. Since the action was taken by the Department of Commerce, not by the FCC, it can be presumed that the porpoises were all properly licensed to transmit.

### Buried antennas will send messages to submarines

Project Sanguine, the Navy's experimental system for communicating with submarines without requiring them to surface to receive messages, may be located permanently in Texas, with Michigan's Upper Peninsula as a possible second site. The present site of the ex-

perimental Sanguine station, in Wisconsin, is being moved because of public opposition, based on (probably unfounded) fears that the low radio frequencies might endanger life, and (possibly more reasonable) objections to the large swaths that would have to be cut to bury the antennas and provide access roads for maintenance.

The Navy's very-low-frequency test transmitter was installed near Clam Lake in northern Wisconsin in 1968. It consists of two 14-mile-long aerial antennas, one running east and west, the other north and south. A buried antenna installed beneath the north-south aerial proved that transmission from an underground antenna is as effective as from one above the ground, according to a Navy spokesman.

The proposed Texas site, about 60 miles northwest of Austin, is a tableland with little water and vegetation and a climate suited for year-round construction activity. Both it and the proposed Michigan site are on pre-Cambrian granite, which is dry and has low conductivity.

### Built-in automotive tester checks cars by electronics

An automatic vehicle test system that could reduce maintenance time on military vehicles by as much as 90 per cent is being tested by RCA for the 14

(continued on page 14)

# JERROLD HAS TAKEN THE MYSTERY OUT OF MASTER ANTENNA TV.

Now, you don't have to worry about decibels or any other theory. Just pick out one of the Universal Systems shown in the Jerrold Instant MATV Guide, install it and you have an excellent system.

If you can deliver good TV signals to one set from one antenna, you can easily install any system in this guide.

Complete with actual Layouts, Bills of Materials and Installation Tips.

Send for your Jerrold INSTANT MATV Guide today.

## IT'S FREE!

**JERROLD ELECTRONICS CORPORATION**  
P.O. BOX 350, 200 WITMER ROAD, HORSHAM, PA. 19044

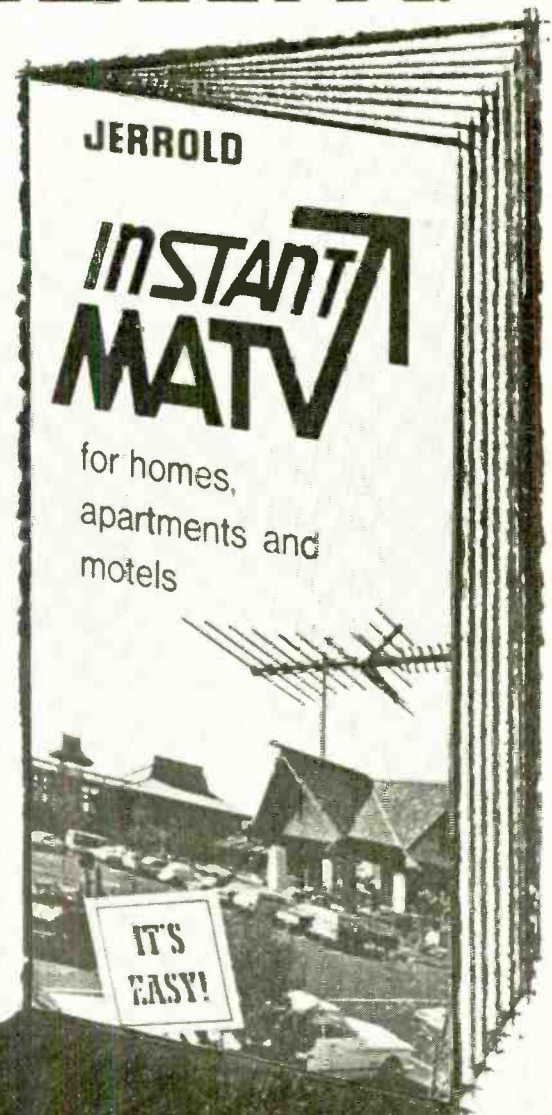

# DISTORTION-TEST AUDIO EQUIPMENT

- *easily*
- *quickly*
- *accurately*

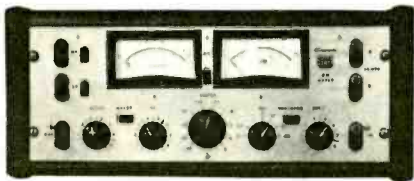

**Now the TECRON IMA makes measuring IM distortion even easier than measuring THD!**

Just one piece of equipment has both internal oscillators and inter-modulation distortion analyzer. Simply connect the oscillator output to the input of the test unit, and hook the unit's output to the input of the analyzer. One quick set up, then switch a single control to simultaneously adjust input and output levels. Take up to ten power level measurements in 5db steps in just 60 seconds! Readings over a wide span of output levels fully describe the distortion characteristics of the test unit.

The IMA itself has a guaranteed residual IMD of less than 0.005% (typically under 0.003%). There are seven IM ranges with accuracy assured to within 5% of full scale (+0.005% on the 0.1 full scale range).

As all other TECRON laboratory instruments, the IMA is of advanced design, ruggedly constructed from highest quality components by skilled American craftsmen.

Product literature is free upon request. For a technical discussion on the advantages of using IM testing to detect audible distortion, send 25¢ for A.E.S. Preprint No. 871(B-9) to Crown International, Box 1000, Elkhart, Indiana, 46514, U.S.A.

Full input and output metering; also full input and output monitoring oscilloscope terminals ■ solid state construction, utilizing FETs for stability and compact size (7"x 19"x 7") ■ full complement of level controls ■ two internal oscillators eliminate the need for additional test equipment ■ rack mount list price \$570, with walnut cabinet \$595

*Made Only in America*



## TECRON

Circle 5 on reader service card

# new & timely (continued from page 12)

Army. It is somewhat reminiscent of the Volkswagen computer self-analysis system described in this magazine November, 1972 (page 37). The RCA unit is, however, a two-stage device, with which the vehicle can be given a quick check to assure that it is in satisfactory operation condition, then diagnosed more carefully if the reading shows that it is



**AUTOMOTIVE VEHICLE TEST SYSTEM, built by RCA, can reduce checking time by 90%.**

not operating as it should.

Called a Built-In Automotive Test System, it consists of a diagnostic connector, a vehicle readiness unit and a vehicle test meter. The diagnostic connector is mounted on the dashboard and linked to sensors that monitor the electrical system, carburetor and a couple of dozen other components and functions, ranging from the efficiency of oil filters to fuel and water gages.

For a road test, the vehicle readiness unit is plugged into the connector. If everything is in order, a green lamp lights; if there is a non-critical problem a yellow light appears, and if the fault is one that demands immediate correction, the light is red.

If repairs are indicated, the vehicle is moved to a maintenance area and the vehicle test meter and programmable diagnostic unit plugged into the diagnostic connector. The various components and functions are then checked out and the trouble pinpointed.

Although developed for military use, the system could lead to similar equipment for checking out civilian commercial vehicles. **R-E**

Radio-Electronics is published by Gernsback Publications, Inc. 200 Park Ave. S. New York, N.Y. 10003 (212) 777-6400  
President: M. Harvey Gernsback  
Secretary: Bertina Baer

### ADVERTISING SALES

**EAST**  
Stanley Levitan, Eastern Sales Mgr.  
Radio-Electronics  
200 Park Ave. South  
New York, N.Y. 10003  
(212) 777-6400

**MIDWEST/Texas/Arkansas/Okla.**  
Ralph Bergen  
The Ralph Bergen Co.  
6319 N. Central Ave.  
Chicago, Ill. 60646  
(312) 792-3646

**PACIFIC COAST/Mountain States**  
Jay Eisenberg  
J.E. Publishers Representative Co.,  
8560 Sunset Blvd.,  
Suite 601,  
Los Angeles, Calif. 90069  
(213) 659-3810  
420 Market St.,  
San Francisco, Calif. 94111  
(415) 981-4527

**SOUTHEAST**  
E. Lucian Neff Associates  
25 Castle Harbor Isle,  
Fort Lauderdale, Florida 33308  
(305) 566-5656

### MOVING?

Don't miss a single copy of **Radio-Electronics**. Give us:

Six weeks' notice

Your old address and zip code

Your new address and zip code

**ATTACH  
LABEL  
HERE**

name (please print)

address

city state zip code

Mail to: Radio-Electronics  
SUBSCRIPTION DEPT., BOULDER, COLO.  
80302

# A LITTLE MITS GOES A LONG WAY.

The MITS 1200 Series Pocket Calculator will give about 60 hours of addition, subtraction, multiplication, and division, or will run in "passive mode" for 150 hours on 5 penlight batteries.



- Bright LED Display
- 100% American made
- Leading Zero Suppression
- Automatic Display Cut-Off
- Fixed Decimal Output (2-4 place)
- Chain and Mixed Operation
- Clear and Clear Entry Keys

## PRICES

MODEL*	We Assemble	You Assemble
1212 (12 digits)	\$99.95	\$89.95
1209 (9 digits)	\$79.95	\$69.95
1206 (6 digits)	\$59.95	\$49.95

SIZE: 5-3/4" x 3-1/4" x 1-1/2"

\*NOTE: All models have 12-digit capacity.

## AC Adapter

Equips any MITS 1200 Series Calculator for operation from 110 VAC . . . . . \$6.95

**Carrying Case** (very leatherette) . . . \$5.95

# MITS®

## Micro Instrumentation & Telemetry Systems, Inc.

5404 Coal Ave., S.E., Albuquerque, New Mexico 87108  
505/266-2330

Enclosed is a Check for \$ \_\_\_\_\_

or  BankAmericard # \_\_\_\_\_

or  Master Charge # \_\_\_\_\_

or  Purchase Order # \_\_\_\_\_

Include \$5.00 for Postage and Handling

Model # \_\_\_\_\_  Kit  Assembled

Please Send Information on Entire MITS Line.

NAME \_\_\_\_\_

ADDRESS \_\_\_\_\_

CITY \_\_\_\_\_

STATE & ZIP \_\_\_\_\_

MITS / 5404 COAL AVE. SE / ALBUQUERQUE, NM 87108

Circle 6 on reader service card

Dreaming  
about a pair  
of \$300  
condenser  
microphones?

Think  
seriously  
about these:  
\$39.75\* each!



Model 1710 Electret Condenser  
Omnidirectional Microphone

All of the great condenser advantages are here without compromise. Flat, extended range, excellent transient response, high output, low noise, and ultra-clean sound. But the new E-V electret condenser microphones need no high voltage power supply. Just an AA penlite battery to operate the built-in FET impedance converter. The result is studio performance without complications and at a dramatically lower price.

There are 4 new E-V electret microphones, including cardioid models, from \$39.75 to just \$75.00, audiophile net. Second-generation designs with unusually high resistance to heat and humidity. Hear them today at your nearby Electro-Voice soundroom. Or write for details.

**More U. S. recording studios use Electro-Voice microphones than any other brand.**

\*Suggested retail price. Microphones shown on Model 421 Desk Stand. \$12.00 each.

**ElectroVoice®**  
ELECTRO-VOICE, INC., Dept. 772E

613 Cecil Street, Buchanan, Michigan 49107  
In Europe: Electro-Voice, S. A., Römerstrasse 49,  
2560 Nidau, Switzerland

**Gulton**  
COMPANY

Circle 7 on reader service card

# letters

## WE CAN'T AGREE

We read Herb Friedman's article—"Unscrambling 4-Channel Stereo," *Radio-Electronics*, May 1973. Unfortunately, we must take exception to your emphasized statement, "In short, the scope traces indicate what the listener perceives, not the electrical power distribution." The statement is untrue and misleading to the consumer.

As of last November, we completed a survey of the matrix and discrete 4-channel equipment available to us at that time (see enclosed report, "Quadrasonics—Reality or Myth?") We used all the test records and equipment you did for your report. We also evaluated the Panasonic CD-4 unit which we find to be slightly better than the JVC unit. The circuitry is also slightly different in the Panasonic unit. At present, we are completing the evaluation of all the remaining equipment available.

In the course of our study, we also used the vector scope displays. After much thought, we asked ourselves the question—"What do they really mean?"—and concluded that at present no one knows their true interpretation. Therefore, we decided not to publish our vector scope illustrations. In the course of events, the Hirsch-Houck Laboratories also completed and published their report. We wrote to Julian Hirsch, stating that the scope displays are electrical in nature while 4-channel sound is naturally psychoacoustic, continuously controlled by the ambience of a given listening room, and no two rooms are alike. Further, the scope displays would be the same no matter what type of room was used, but the sound perceived by the listener would vary considerably. Mr. Hirsch replied, that Benjamin Bauer (CBS Laboratories) also wrote him and pointed out that the scope displays can give misleading results since they do not indicate phase relationships which can have a strong effect on the psychoacoustic results. When a program is "discrete" in nature, the scope does give a good idea of the channel separation and directional integrity of the program. With the bulk of the matrixed material, it tells you very little. We also found that with matrixed material the quad effect is highly affected by even a moderate amount of listener movement. Only a "full-logic" SQ decoder comes near the discrete 4-channel sound. But, the "full-logic" units have a "pumping"

action as the unit switches, which is annoying to the serious listener. Both Mr. Hirsch and I agree with Ben Bauer that there is at present no valid objective test means for evaluating 4-channel sound—except our ears!

Subsequently, Mr. Hirsch published excerpts from Ben Bauer's letter in his article which appeared in the March 1973 issue of "Stereo Review." It points out the fallacy of trying to identify scope displays as what the listener perceives rather than what they truly are—electrical vector responses, unaffected by the room ambience that affects all sound. Remember, the scope does not respond psychoacoustically, but *only* electrically!

This letter is not intended to discredit you or your report, but simply the interpretation of the vector scope displays. Most all reports I've read make the same error.

Perhaps, someday, we will be able to use the vector scope displays *after* we learn what they really mean.

B. V. PISHA

Director

Audio Electronics Laboratory  
Albertson, N.Y. 11507

*Firstly, you claim to have made a survey of 4-channel equipment using all the test records and equipment I used. Then, I find in the report you enclosed with your letter the statement "We believe some sort of test record be issued by RCA, JVC or Panasonic for the CD-4 system . . ." Since I in fact used such a test record, and since the scope phase-amplitude comparator I used is a proprietary equipment of Tridac Laboratories, it is obvious we did not use the same equipment.*

*If you are referring to the scope used by Julian Hirsch for his article—to which Ben Bauer referred in his now famous letter which Julian printed, then I must point out that he used "home entertainment" display; his scope traces are at best an approximation under best-case conditions of what I illustrated. As for Bauer's letter to Julian, it makes the statement ". . . let the signals applied to the front channels be equal in strength, but displaced in phase. The oscilloscope will then display a sharp "center front" line . . ."*

*Now I will be charitable and assume Bauer's statement is either A) a typographical error, or B) "home entertainment"*

*(continued on page 22)*



# SOUTHWEST TECHNICAL PRODUCTS CORPORATION

219 W. RHAPSODY

SAN ANTONIO, TEXAS 78216

PHONE: 512 DI 4-3140

July 1973

Dear Radio-Electronics Readers,

This month I would like to tell you about one of our kits that is not exotic, or particularly clever in any way; just awful useful. This little instrument is called the "Digi-Viewer" and it is used to troubleshoot, or design digital logic systems. It consists of a test clip that grabs onto the two sides of the standard inline package and makes contact with all of the pins. A 16 conductor ribbon cable connects the clip to a box with 16 pilot lamps mounted on top around an outline of the IC package. Inside are 16 Darlington pairs like the diagram to the right. These transistors will conduct and turn the lamp ON only if there is a logic "1" condition at that pin on the IC. If there is a logic "0" condition the lamp stays out of course. The power supply to drive the lamps is in the box, so the only loading on the circuit is the small amount of base current drawn by the Darlington transistor pair.

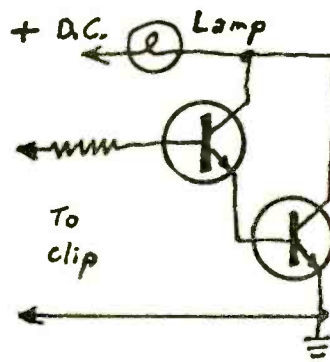

Now, as some of you may be aware, Hewlett Packard makes a much neater little clip with LED's that does much the same thing and at only about ten times the cost. Unless you have memorized all the pin connections in the TTL logic families, using our box is probably easier because it comes with a set of cards showing the internal parts and connection points of the various types of circuits. We have 60 different cards available for the various RTL and TTL types and also blank cards that you can use to make outlines of oddballs. These cards snap in place between the two rows of lamps.

An instrument like this makes troubleshooting much faster because you can test the circuit under actual operating conditions and the lamp display lets you see what is going on logic-wise at all pins simultaneously. You might have to slow the operating rate way down in order to do this, but this obviously does not effect the operation of the logic in most cases. The only circuits that might get upset by the clip and cable capacity are things like a 74121 one-shot set up for a very narrow output pulse.

Digi-Viewer comes in a 7 x 4 x 3 cabinet with a brushed gold finish and wood grain side panels. Construction is simple and fast. It shouldn't take more than two or three hours even if you work slow. You can have one for only \$19.86 and postage for 4.0 pounds. This is such a bargain that we almost feel like we should write (cheap) after the price like "Mad" magazine does.

How about a free catalog listing our other kits? If you don't already have one, or if it is out of date, circle our number on the reader service (bingo) card. We will get one right back to you.

Daniel Meyer

*Dan*

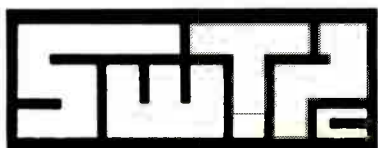

SOUTHWEST TECHNICAL PRODUCTS CORPORATION

DEPT. RE-L

219 W. RHAPSODY, SAN ANTONIO, TEXAS 78216

# USE IT ALL AS YOU GET READY FOR A NEW CAREER...

## \$1,500.00 worth of two-way radio electronic communications equipment!

Bell & Howell Schools announces a new learn-at-home program that gives you "hands on" experience with commercial-grade equipment—as you prepare for a business of your own in two-way radio electronic communications servicing.

You *need* "hands on" experience with a real, commercial-band FM transceiver and actual commercial-grade test equipment—to take full advantage of growing opportunities in electronic communications.

Two-way radio communications is a healthy growth area in electronics. And it's lucrative. Almost two million commercial two-way radio systems now serve as vital communications links for trucks, planes, boats and taxis. And the FCC requires each system to have its equipment serviced regularly by a licensed technician. That's where *you* come in. But you need career-oriented training—plus your FCC license.

Knowing how to put an amateur radio kit together won't help when you're "on the job"—servicing two-way radio systems for aircraft or advising trucking companies about their land-mobile communications system. For that, you need "hands on" experience with the real thing. This unique new Bell & Howell Schools learn-at-home program that gives you just that. You can work with the equipment by attending one of our special "help sessions" or by dropping by one of the Bell & Howell resident schools. If neither of these plans

is convenient, you can have the equipment shipped to your home in return for a \$100 deposit, which is refundable when you return the equipment.

Find out more about this exciting new Bell & Howell Schools program. There's no obligation.

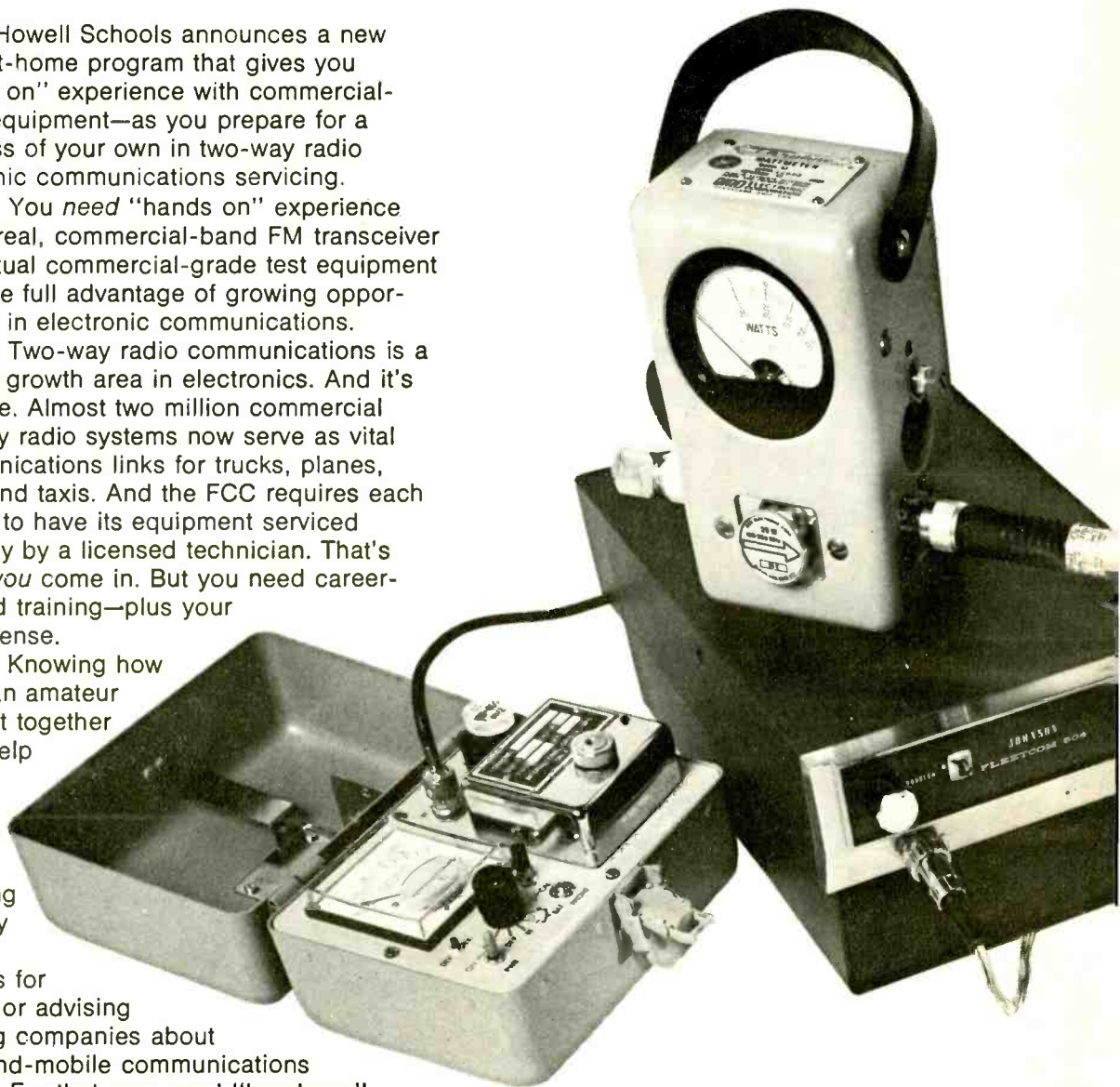

**For free facts, mail attached card today!**

# Let Bell & Howell Schools help you get ready for an exciting career or business of your own in two-way radio electronic communications!

Bell & Howell Schools has helped thousands of people prepare for careers—and businesses of their own—in electronics. You can have absolute confidence in the thorough training you get.

Expert instructors at Bell & Howell Schools plan each program to answer a single question: "What qualifications will you need to take advantage of *actual career opportunities* in electronics?" They then build each program to give you those exact qualifications.

To get ready for a business of your own in two-way radio, you need: 1) career-oriented training; 2) FCC License; 3) "hands on" experience with commercial-grade equipment. Bell & Howell Schools now offers this new at-home training program that gives you all three. (See FCC License Warranty on attached card.)

## JUST LOOK AT ALL THE EQUIPMENT YOU'LL WORK WITH DURING YOUR TRAINING PROGRAM WITH BELL & HOWELL SCHOOLS!

*Commercial-Band FM Transceiver* . . . exactly the kind of two-way radio you'll service throughout your career

## FCC REGULATIONS GIVE YOU THE OPPORTUNITY TO START YOUR OWN BUSINESS!

The Federal Communications Commission requires that all commercial two-way communications systems be checked and serviced by a licensed technician at regular intervals.

As a Bell & Howell Schools graduate, you'll have the technical know-how you need. With your FCC license, you can go out and eventually build your own business—signing contracts with companies that use two-way radio. FCC regulations could mean security and regular income for you!

## BELL & HOWELL SCHOOLS OFFERS YOU THESE SPECIAL ADVANTAGES:

**Help Sessions** Scheduled regularly every few Saturdays at the Bell & Howell Schools and in many other cities throughout the U.S. and Canada. Top instructors give you personal help and guidance.

**Transfer Privileges** After completion, you can transfer to any of the resident schools for more advanced study, if you wish.

**Lifetime National Placement Assistance** Helps you locate a job where you want to anytime after you complete program.

**Veterans' Benefits** We are approved by the state approval agency for Veterans' Benefits.

**Student Financial Aid** We are an eligible institution under the Federally Insured Student Loan Program.

## EXCLUSIVE ELECTRO-LAB®—YOURS TO KEEP!

To make sure you get practical experience with instruments used daily by professionals, we've integrated into your program three precision instruments you assemble yourself and keep:

**Design Console** Use this to rapidly "breadboard" circuits without soldering.

**Oscilloscope** Offers bright, sharp screen images, 3-way jacks for leads, plugs.

**Transistorized Meter** Registers current, voltage and resistance.

## FOR FULL INFORMATION, MAIL THE ATTACHED CARD TODAY! OR WRITE:

An Electronics Home Study School  
DeVRY INSTITUTE OF TECHNOLOGY



ONE OF THE  
**BELL & HOWELL SCHOOLS**  
4141 Belmont, Chicago, Illinois 60641

406R3

### Deviation Meter

. . . model favored by many working technicians to check modulation of transmitted signal.

### Frequency Meter . . .

highly sensitive instrument used to check signal frequency within precise tolerances established by government standards.

### Power Output Meter . . . meter

used almost universally by trained and licensed technicians to check power output—or wattage—of signal.

### Alignment Generator

. . . a custom-designed unit you use to generate test signals for transceiver alignment.



**SPECIALS OF THE MONTH**  
**MAN 3** (tvde) \$2.45 ea. Buy 3 or more @ \$1.95 ea. 7 segment display compact rt. hand decimal point.  
**MAN IV** (type) \$2.95 ea. Buy 3 or more @ \$2.75 ea. 7 segment display (LIKE MAN 1)

TTL SPECIALS						
7400	7401	7402	7403	7404	7405	\$.25 ea.
7408	7410	7420	7430	7440	7460	.25 ea.
74L00	\$ .40	7451	.25	7489	3.25	
74L02	.40	7453	.25	7490	.99	
74L04	.40	74L71	.50	7491	1.05	
74L20	.40	74L72	.50	7492	.75	
74L30	.40	74L73	.75	7495	.90	
7413	.95	74L74	.75	74123	.99	
7441	1.20	7473	.55	74153	1.45	
7442	1.20	7474	.55	74154	1.75	
7443	1.20	7475	.89	74161	1.65	
7446	1.40	7476	.55	74165	2.45	
7447	1.20	7483	1.20	74181	4.50	
7448	1.25	7485	1.20	74192	1.65	
7450	.25	7486	.55	74193	1.65	

LINEAR SPECIALS	
LM300 Positive Volt Reg.	\$.95 ea.
LM301 Hi Performance Amp.	.75 ea.
LM302 Voltage Follower	.95 ea.
LM304 (TO5) Neg Volt Reg.	1.25 ea.
LM305 Positive Volt Reg. (TO5)	1.35 ea.
LM307 Super 741	.45 ea.
LM308 (TO5) Micro Power op. amp	1.75 ea.
LM309H (TO5) Volt 200 ma V. Reg.	.95 ea.
LM309K (TO3) 5 volt 1 amp reg.	1.95 ea.
LM311 (TO5) Comparator	1.50 ea.
LM320 (TO3) -5.2 neg. reg.	1.95 ea.
LM320 (TO3) -12 neg. reg.	1.95 ea.
LM320 (TO3) -15 neg. reg.	1.95 ea.
LM380 (dip) 2 watt audio amp.	1.45 ea.
LM3900 Quad Amp.	.50 ea.
NE565 Phase lock loop	2.95 ea.
NE566 Function Generator	2.95 ea.
NE567 Tone Decoder	2.95 ea.
709 Op. Amp	\$.25 ea. or 10 for 2.00
723 Volt reg.	.95 ea. or 5 for 4.00
741 Freq. Comp.	.45 ea. or 10 for 4.00
747 Dual 741	.95 ea. or 5 for 4.00

12 DIGIT CALCULATOR SPECIALS	
5001 LSI—add, subtract, multiply and divide Automatic overflow 40 lead pkg. use with 7 segment readout with complete data	\$8.95 ea.
Data only (refundable with purchase)	\$1.00 ea.
5005 LSI—Four function calculator with extra storage register for constant memory application chain calculations add, subtract divide, multiply and memory. Use with 7 segment readouts with complete data	\$11.95 ea.
Data only (refundable with purchase)	\$ 1.00 ea.

**LED'S**  
 MV50 (type) red emitting LED .29 ea. or 4/1.00  
 MV5020 (type) Large Red. LED .39 ea. or 3/1.00  
 ME4 Ir Red LED .69 ea.

MEMORIES—ARE MADE OF—	
1101 256 Bit Ram Mos	2.95 ea.
1103 1024 Bit Ram Mos	7.95 ea.
7489 64 Bit Ram TTL	3.25 ea.
8223 Programmable ROM	6.95 ea.

DATA INCLUDED WITH ANY MEMORY

**MOS SHIFT REGISTERS—**Hey look me over—choose or mix  
 2500 series dip pkg. chose or mix 4 for \$1.00  
 2502 Quad 256 Bit capacity multiplexed dynamic shift registers .30 ea.  
 2504 (mini) 1024 bit capacity multiplexed dynamic shift registers .30 ea.  
 2506 (mini) Dual 100 bit dynamic shift registers .30 ea.  
 2509 Tri state output dual 50 bit static shift reg. .30 ea.  
 2510 Tri state output dual 100 bit static shift reg. .30 ea.  
 2511 Tri state output dual 200 bit static shift reg. .30 ea.  
 2518 Hex 32 bit static shift register .30 ea.  
 2519 Hex 40 bit static shift register .30 ea.  
 2521 (mini) dual 128 bit shift register .30 ea.  
 2522 (mini) dual 132 bit shift register .30 ea.  
 2524 (mini) 512 bit recirculating dynamic shift .30 ea.

NOTE: 2500 MOS SHIFT REGISTERS UNTESTED FACTORY SECONDS

Satisfaction guaranteed. California residents add sales tax.  
 All except where noted are fully tested.  
 Min. Order \$4.00 Prepaid in U.S.  
 Orders Filled within 3 days after receipt.  
 Note: add \$ .50 per spec. sheet for items priced at less than \$1.00 each.

**INTERNATIONAL ELECTRONICS UNLIMITED**

P.O. BOX 2238  
 WALNUT CREEK, CALIF. 94595  
 Circle 9 on reader service card

**LETTERS**

(continued from page 16)

ment display" is incorrect.

Moving on, I find you refer to the "pumping" of a full-logic SQ decoder. Since the famed CBS Laboratories Audiomax also pumps, and since no one seems to be upset about pumping on the broadcast end, so what! As far as calling attention to the pumping is concerned, in the New York Audio Society Newsletter you enclosed, you make the statement concerning the Sony SQD-2000 full-logic decoder "... but certainly the best of the matrix decoders. The SQ encoded records sounded just great ... the only matrix unit that comes close to producing a true discrete program." What happened to the "pumping" in your review? Let's play the game with the same set of rules.

Finally, I come to psychoacoustics. Mostly hogwash. A crutch to support poor performance. Both Messrs. Bauer and Itoh depended heavily on psychoacoustics in the original papers for matrix sound; they "proved" that psychoacoustics produced a three-dimensional sound field with as little as 3 dB separation. And the systems laid a colossal egg with both consumer and technician. The ink was hardly dry on their reprints before the SQ matrix decoder was modified (5 times to date), while the vario-matrix QS was talked about for a year. Psychoacoustics or no psychoacoustics, in the typical living or listening room of 20' x 25' x 8' (or smaller) the sound will appear to arrive from the speaker with the greatest acoustic power, while mono will still be derived from two positive-phased speakers. Psychoacoustics might affect the total three-dimensional "feeling", but it cannot destroy what both Eargle and Bauer term the "center of gravity", which can be properly interpreted from scope displays—assuming you know what scope equipment to use.

The only problem I find with scope displays is the lack, rather total absence, of program phase cancellation from matrices. While we can play games with sine waveform we cannot do the same with program waveform, where phase variations can create totally new and original waveforms, which can sound plain lousy. It is for this reason that the program preparation and production requires a high degree of artistry, as contrasted to total dependence on psychoacoustics.

Until I am shown otherwise, I will stick to scope displays of SQ and CD-4 as they correlate with what I can hear. But as stated in the article, this is not necessarily true of QS (not as of now, perhaps it will be ... sometime).

HERB FRIEDMAN  
 Franklin Square, N.Y.

**HISTORIC GERNSBACK MAGAZINES**

During more than fifty years in electronics, I have collected a large number of early magazines including many Gernsback publications. Included are copies of:

Electrical Experimenter	1914-18
Practical Electrics	1922
Short Wave Craft	1934-36
Science & Invention	1929
Radio Craft	1926-on

as well as numerous other American, Canadian, and English publications back to the early 1920's.

Could you kindly suggest names of any persons or firms who could use them?

WILLIAM H. BRAKES  
 1619 Nanaimo St.  
 New Westminster, B.C.

**ATTENTION ALL SERVICE TECHNICIANS**

Recently I have become very seriously interested in the chain of events which seems to be indicating a collapse of the NATESA/NEA merger committee and the function for which it was created. As a member of the silent majority, I have kept my mouth shut in the normal manner. However, the time seems to be apparent for the silent majority to begin to make some noise. After all, the creation of one STRONG national association will be in the interest of the majority—perhaps, however, not in the interest of a FEW who will—or may—lose some personal glory from the change.

It is with the above in mind that I—as a general member—have come to the realization that the best thing is to make my feeling known. This I am doing.

The merger committee can, I am sure, come up with a good workable national association out of the groundwork of the two nationals now in existence. As one strong national, it will be able to provide a united front to all the enemies which both associations now are faced with. There would be no reason for any future problems which the strong national would not be able to handle. The key here is ONE STRONG NATIONAL.

Mr. M. L. Finneburgh, Sr., EHF and the merger committee have tried to do a good job. However, when events happen, like what has happened recently, then NO committee can function with any degree of success. If certain members of the merger committee are in this only for personal glory, then I maintain that the time has come to depose these unsung heroes—Let them thank themselves that they are not engaged in these activities in some other fields as those fields may not have waited as long to take care of them. Replace those who do not really represent the majority.

Again, I believe in the merger com-  
 (continued on page 83)

# BOOLEAN ALGEBRA AND COMPUTER SWITCHING

*A look at the mathematical concepts involved in logic systems and how they are applied to the basic electronic switching circuits so vital to the development and maintenance of computers.*

by JAMES F. KENNEDY\*

PHIL, JIM, JOE, HARLO, GEORGE, AND A few other technicians from the Final Test Section of the Rub-A-Dub Electronics Corporation were sprawled out in the large company cafeteria, enjoying their morning coffee break. This was the time for an electronics bull session among the gang. Someone always had a new circuit, or some sort of problem, which would be set forth on a paper napkin or on the table top, much to the disgust of the cafeteria workers. These young men of Final Test were the best in the plant, and were picked for their ability to solve problems and improvise quickly in the everchanging atmosphere of the Final Test Section. An expert from nearly every phase of electronics was represented here. These men dealt with computers for automated testing, environmental testing, measurements, linear amplifier circuits, switching circuits, and many other phases of work in the giant plant.

Jim, one of the newer members of the group, made a face over his stale coffee and addressed himself to Phil: "Say, Master Mind, I walked by the other day when you were working on one of the computers, and I've been wondering what sort of schematic you were using. The sheet was full of the screwiest looking symbols I've ever seen: half moons and triangles and things like that. How about giving me the inside dope so I can breathe the same rarefied atmosphere that you 'brains' use?"

Phil had been around for a number of years and was quite accustomed to this kind of banter. He also knew that Jim really wanted information.

"Tell me what, Son, I'll take fifteen minutes off and teach you all I know about computers and then you, TOO, will be an expert!"

As the chuckles subsided around the table, Phil reached for a clean paper napkin, lit another cigarette, and patiently began an explanation.

"Tell me, Jim, have you ever heard of Boolean algebra?"

As he surmised, the answer was negative, so he continued.

"Well, Boolean algebra is named for an old timer named George Boole who lived back in the eighteen hundreds in England. (Of course they didn't have computers in those days!) George was a combination philosopher-mathematician and he developed a system for proving by math whether a logical statement was true or false. He'd convert the statements to equations and then solve 'em. The book he wrote over a hundred years ago has a lot of 'modern math' in it."

Joe interrupted from across the table, "I can use that book! My kid is only in the sixth grade and I can't tell what he's talking about when he needs help with his math homework!"

Phil smiled and continued, "Technicians aren't usually very interested in philosophy, although sometimes it helps if you're philosophical about it when your wife needs a new Fall wardrobe! However, an electronic technician certainly needs to be concerned with algebra if he expects to get ahead in his job. George Boole's math system should also interest you in your work because it's directly related to computers and telephone switching circuits.

"Computers are so complicated that you can't look at the schematic and trace the flow of information like you do in a radio or TV set. Heck, you might have several pounds of schematics for one computer. So . . . logical diagrams are used to show the action. One triangle or semicircle may represent a complete circuit. These logic diagrams can be represented by equations, and the equations can be simplified by Boolean algebra, which simplifies the circuit and does what the company loves to do: saves 'em money."

Phil glanced at the clock on the cafeteria wall, picked up his empty coffee cup, and said, "Time to head

back to the sweatshop. We'll continue this on our afternoon break if you still want to, Jim."

That afternoon the group gathered again, armed with full coffee cups and plenty of paper napkins for doodling. Phil continued his morning talk just as though it hadn't been interrupted: "Old Geo. Boole was interested in proving whether logical statements were right or wrong. There were only two possible conditions: True or False. You'll find that a computer does things the same way: the circuits are either on or off because the computer uses the binary system, which has only a zero or a one. Incidentally, Joe, I'll bet that if you checked your son's sixth grade math book you'll find that he's already studied the binary system of arithmetic."

Joe choked slightly on his coffee and said, "Say, I'll bet that's what he was doing when I looked over his shoulder and saw him adding 100 and 100 and getting 8. Good thing I kept my mouth shut!"

"That's straight thinking, Robin", said Phil in his best Batman manner. "Remember, we have only two choices in Boolean algebra, True or False. We can say that when a switch is closed this represents a 1, and when a switch is open, this represents a zero. This is why the telephone engineers dug up Boole's system, because it applies so well to switching circuits. Most of the rules of ordinary algebra apply to Boolean algebra, but there are some exceptions. You guys just keep in mind that when we look at Boolean equations we're dealing with switches, and these switches have to be either on or off. That way you'll stay on the right track."

"Someone across the table murmured, "Golly, even I can count up to two. This is peachey keen!"

Phil pretended to ignore the touch of sarcasm, whipped out his pencil, and continued. "Let's start this high level discussion with something to really challenge you experts. Look

\*Electronics Instructor, Camelback High School, Phoenix, Arizona

at this sketch of two simple switches connected in series."



"We'll label our switches 'A' and 'B' and so on. An open switch is a zero, and a closed switch is a one. This circuit is called an AND circuit because A AND B have to be closed before the circuit will operate. Another way to say the same thing is to say that A must equal 1 and B must equal 1 for the circuit to operate. This is written  $A \cdot B = 1$  or  $A \times B = 1$  or  $AB = 1$ . Remember, don't say 'A times B equals 1'. Say, 'A AND B equals 1'."

"This is a simple circuit, but we can deduce several things from it, as Sherlock Holmes used to say. Suppose  $A = 1$  and  $B = 0$ . This means that A is closed and B is open, so the circuit is open, or zero." He wrote on the napkin,  $A0 = 0$ . "Read this as 'A and 0 equal 0'. This rule is just like regular algebra, where a number multiplied by zero equals zero."

Glancing around the group, Phil said, "I know all you eager beavers are in a sweat to get back to the old grind, so let me show you a few more rules for a series circuit while we still have it drawn on the napkin."

Joe spoke up, "Someday I expect to send one of these napkins in to the Patent Office and get rich from some of the circuits you guys draw!"

Phil laughed, and continued. "How about this equation?" He wrote,  $A1 = A$  and said, "A and 1 equals A. The '1' means the switch is closed all the time, like this".



"For this circuit we can say three things:

if A equals 0 the circuit is open and the result is zero.

if A equals 1 the circuit is closed and the result is 1.

In both cases the result is the same value as A, which brings us back to what I just wrote, that A and 1 equals A."

Jim spoke up, "Anybody listening to this conversation would put us down as likely candidates for the nut house, Phil."

Phil laughingly agreed. "It helps! But here endeth the daily lesson. If any of you would like to continue after work I'll be glad to put in some time with you later on today."

As the first shift ended, several of the technicians clustered around Phil's desk, anxious to learn more about Boolean algebra. Phil had noticed many times before that one of the

marks of a good electronics technician was an intense desire to learn.

He began. "It seems strange not to be drawing on a paper napkin, but we'll have more quiet here and we won't have to rush back after our coffee break. One more point about our series circuit before we leave it." He wrote on a scratch pad,  $AA = A$ .

"I'll bet you guys thought that A times A gave A squared. Remember what I told you this morning; this means A AND A equals A. What I mean is that you have a series circuit with both switches in the same position, either open or closed. If A equals 0 the result is 0. If A equals 1 the result is 1 since both switches will be closed. I'll show you pretty soon how these rules apply to more complicated circuits."

Next, he drew a simple parallel circuit on his scratch pad.

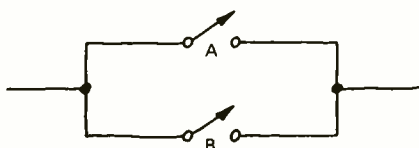

"This is called an OR circuit because there will be current flow if either A or B is closed. The OR function is shown by a plus sign, so that if I wrote 'A + B' you read it 'A or B'.  $A + 1$  is read as A or 1. Remember now; the 1 means that the switch is closed."

Phil drew another parallel circuit and wrote an equation beneath it.

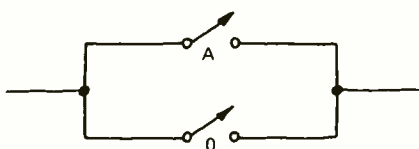

$$A + 0 = A$$

"The 0 by the lower switch means it stays open. If A equals 1 there is a closed circuit. If A equals 0 there is an open circuit. In each case A or 0 equals A. A rule like this may sound stupid now, but as soon as I start to snow you with some more complicated circuits, you'll find that you have to refer back to the basic rules. It's like any other kind of math; no matter how complicated a problem seems to be, you can get it down to some fairly simple rules if you know how to manipulate it.

"Here's another parallel circuit:"

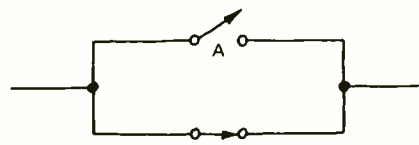

$$A \cdot 1 = 1$$

"One switch is always closed, so the result is always 1, regardless of the value of A".

"Let's look at one more rule for parallel circuits, and then I'll put you to work writing an equation or two for more complicated circuits."

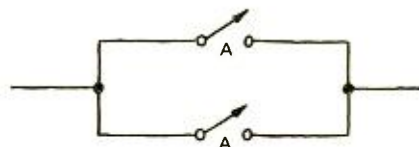

$$A + A = A$$

"This means that both switches are in the same position all the time, either open or closed. If A equals 1, the circuit is closed, or if A equals 0, the circuit is open. In both cases the result is the same as the value of A."

"So far, this hasn't been a brain strain, has it? This stuff will be plenty useful when you have to work on test equipment using computer circuitry, and believe me, more of it is used every day. I wouldn't be here beating my gums about AND circuits and OR circuits if I didn't think you could use the information!" There were no comments from the attentive group, so he sketched another circuit on his pad.

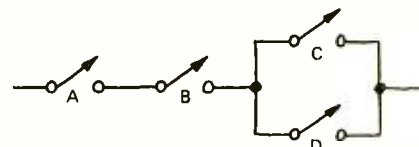

"As you guys can plainly see, this is a series-parallel circuit, so it'll have an AND circuit and an OR circuit in the equation, which is what we're going to try to write". Phil scribbled: (A and B) and (C or D). "This means that for this circuit to operate we must have A and B together, and C or D. Do you see how I got that? This would be abbreviated to read  $AB(C + D)$ . The parenthesis indicate an AND."

How about something like  $A + B + C + D$ ? Well, you know it's going to be a parallel circuit, and we'd say 'A or B or C or D' when we read it. Here it is in picture form."

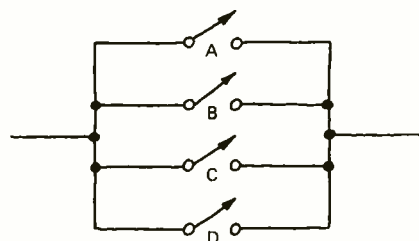

"When you get into more complicated circuits, which you're about to do, you need brackets to show AND functions, like in this one:

$[A + B + C(D + E)] F$ . Watch your step on this one; it shows that A or B or (C and D or E) and F are necessary to complete the circuit. I'll draw it and you follow the equation through the drawing."

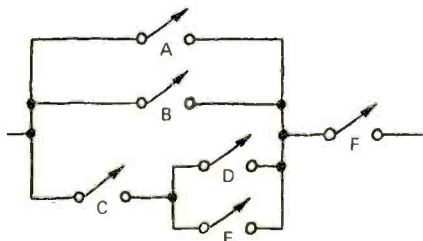

"Computers are plenty complex, but mostly they have thousands of AND and OR circuits in 'em. If we drew the schematics like I've been drawing these we'd soon run out of paper. So, a more compact form is used. This is what you were wondering about, Jim, when you asked me about the funny-looking circles and half moons and things on the schematic of the computer I was working on. Each manufacturer has his own format, but they're fairly uniform. An AND circuit is drawn like this:"

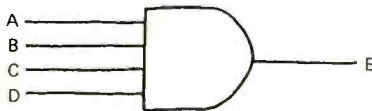

"This is a 4 input AND gate and it would look like this if I drew it as switches:"



"This circuit equation would be written as  $ABCD = E$  and we'd read it as 'A and B and C and D yield E'. Here's a funny-looking one. It's a parallel circuit:"



"Notice the difference; the lines go all the way through the half-moon in this 'Or' circuit. If I draw it as switches it would look like this:"

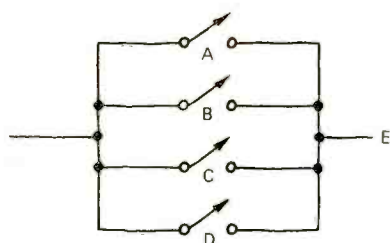

We'd write this as  $A + B + C + D = E$  and we'd read it, 'A or B

or C or D yields E'."

"Okay, now that you guys know all about the subject, let's see if you can draw the equation I put down awhile ago. It was:

$$[A + B + C(D + E)] F."$$

There was a general shuffling of paper and pencils and some grumbling about "the half moon is in the wrong phase", as the group struggled with the problem. Phil watched carefully and finally grabbed Harlo's masterpiece before he could change his mind about how to draw it.

"You fellows who've been mouthing off so much should take a lesson from Harlo. This is what your logic diagram should look like. Notice how much simpler it is to draw it this way than when I drew it with a bunch of switches."

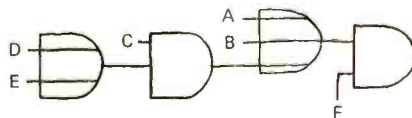

Phil continued. "AND gates are the decision-making elements in a computer. If three conditions occur simultaneously in this AND circuit, that

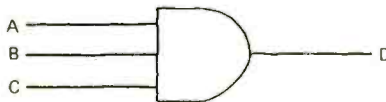

is, if a signal is present at A and B and C at the same time, then there will be an output at D. This could mean that when three conditions are satisfied simultaneously the computer will signal that your checking account is overdrawn, or a light will signal to fire the retrorocket, or any other situation could be covered. There might be more than three inputs to the gate, or fewer than three."

The OR gate is the mixing element. There is an output from the OR gate when any or all of the inputs are present. This gate feeds several different inputs into one circuit without any interaction between the various inputs."

Phil glanced at his watch, groaned, and said, "It's getting late, so let me add a little bit here about these 'inputs' that go to the gates. These inputs are rectangular pulses, or square waves, and they represent a voltage level. The computer might use a pulse that went from 0 volts to a positive 6 volts. The 6-volt level could represent a '1' in our system, and the 0 volt level could represent a '0', or the computer could be designed so it was just the other way around. These pulses may be running around in the computer at the rate of a half million or so per second, so you can see that decisions and calculations can be made

pretty fast. All the information fed into the computer is put into the binary system. Here's a binary 1101 as it would be in computer language."



"Now that you know all about Boolean algebra, see if you can remember it until tomorrow because I'll show you how to simplify a switching circuit when we have our morning coffee break."

Next morning, to save time during their coffee break, Phil passed out sheets of paper with a logic diagram and equation drawn on them.

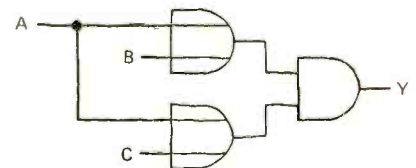

Pointing to the paper, he began. "You can see that this is a 2-input AND circuit fed by two OR gates. Let's see what we can do to simplify the equation and save the computer factory a pile of money. Okay? Let's start off first like regular algebra, and multiply together the stuff inside the parentheses. If you're on the ball, you should get  $AA + AC + AB + BC = Y$ . Notice that A times A gives AA, and not A squared. Also, if you recall, we said that  $AA + A$ , so we can replace the AA in the equation by A. This gives us  $A + AC + AB + BC = Y$ . Next, we can factor out the A term which gives

$$A(1 + C + B) + BC = Y.$$

Think back now; remember our rule that said 'A1 = A'? That meant that A must be present for the circuit to operate. Well, the first term of our equation,  $A(1 + C + B)$ , comes under this rule. If the A is open the circuit will be incomplete, because this means A and 1 or C or B. So, we can replace that entire term,  $A(1 + C + B)$  with just plain old A. When we do that, the equation boils down to  $A + BC = Y$ , and here's how it looks in a logic diagram:



This circuit, with two gates, gives the same results as the one we started with, which had three gates. This may not seem like much of a saving, but there are a heck of a lot of gates in a computer, so this saving can be multiplied many times. You fellows may not be designing computers in the

(continued on page 68)

# Introd





# ucing

Now your Zenith Distributor has the parts and accessories you need in one convenient place – your Zenith One-Stop Shopping Center.

You'll find the complete Zenith line there... bigger and broader than ever... including:

## REPLACEMENT PICTURE TUBES



Famous Super Chromacolor® picture tubes in a range of sizes to replace a total of 80 industry types. Plus Sunshine® and Cinebeam picture tubes to fit almost any brand of color TV. And Zenith black & white picture tubes to replace 401 other types of B & W tubes.

## REPLACEMENT RECEIVING TUBES



A complete line of more than 1,000 Zenith quality tubes... the same tubes as used in Zenith original equipment. Built to operate with great reliability – to cut your callbacks. And they have the long life needed to increase the satisfaction of your customers.

## ZENITH QUALITY PARTS



All the parts you need, from bel fuses to TV knobs. The star is the Zenith Instant Parts Program (ZIP). It puts the 100 most used replacement parts at your fingertips, in a specially designed, compact rack. ZIP makes inventory and re-ordering fast and easy for you. Also, Zenith now offers a line of capacitors, resistors, integrated circuits and universal semi-conductors.

## ZENITH QUALITY ACCESSORIES



Here are just a few! Quad, stereo and monaural headphones. Broadened line of outdoor antennas featuring 13 all-new Super Chromatenna models. Complete new Chromatenna indoor antenna line. Antenna rotors. Three grades of batteries in a wide range of sizes. Electronic chemicals, including tuner degreaser, tuner cleaner, circuit cooler and tape head cleaner. "Cabinet Care" furniture polishes. Cassette and 8-track recording tape cartridges.

Beside parts and accessories, your Zenith Distributor has the specialized "know how" to help solve tough service problems. Come in or phone today.

**ZENITH**<sup>®</sup>  
For quality you can depend on,  
in replacement parts and accessories –  
all in one convenient place

# Changes come fast in electronics.



From  
tube  
to  
LSI

Take a look at the race in circuit technology. In the 1960's the tubes at the left made way for the transistors at the right. Today, transistors are surpassed by the large scale integrated circuit (LSI) at the far right. This circuit, less than a quarter inch square, replaces over 6000 transistors!

There's big money to be made by the men who stay ahead of this technology race. Put yourself

ahead with NTS Home Training! You get the latest, most advanced equipment (at no extra cost). More solid-state units, and more advanced technology. Plenty of training with integrated circuits, too! As an NTS graduate, you enter a world of electronics you're familiar with. You have a thorough working knowledge of solid-state circuitry. You're ready to tackle bigger jobs at higher pay!

## NTS COLOR AND B & W TV SERVICING

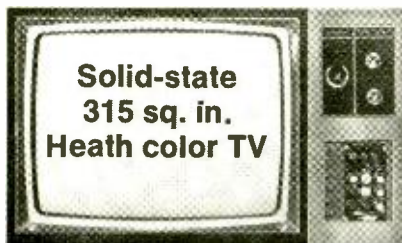

**Solid-state  
315 sq. in.  
Heath color TV**

Build and keep the largest, most advanced color TV made! Over-all solid-state design, ultra-rectangular screen, matrix picture tube, built-in self-servicing features, "Instant On," A.F.T., solid-state, 24-channel detent UHF/VHF power tuning, and much more! Also build and keep AM-SW Radio, Solid-State Radio, FET Volt-Ohmmeter, and Electronic Tube Tester. Learn trouble-shooting, hi-fi, stereo, multiplex systems, radio, color and B & W TV servicing.

Learn sophisticated solid-state circuitry as you build this B & W TV receiver. Lo-Silho "Superhet" Radio, FET Volt-Ohmmeter, Solid-State Radio, Electronic Tube Checker, and Signal Generator. TV

and all other equipment are yours to keep.

**Solid-state  
B & W TV,  
74 sq. in.  
picture  
(cabinet  
included)**



## NTS ELECTRONICS & COMPUTER TECHNOLOGY

Build and keep this exclusive NTS Compu-Trainer. It teaches you the

**Solid-state  
Compu-Trainer  
14 integrated  
circuits replace  
198 transistors!**



same principles used in million-dollar systems. Contains 14 inte-

grated circuits! All Solid-State! You perform all wiring and patchcording. No shortcuts. No pre-wired circuit boards. Your training is complete! Also receive an FET Volt-Ohmmeter and a 5" wide-band Solid-State Oscilloscope.

## NTS ELECTRONICS COMMUNICATIONS

Gain the prestige and earning power of owning an F.C.C. First Class Radio-Telephone License. Two comprehensive NTS courses cover the big opportunity field of transmitting and receiving.

You build and keep 14 kits, including this amateur phone 6-meter VHF Transceiver, NTS's exclusive 6-transistor Solid-State Radio, and a fully transistorized Volt-Ohmmeter. Also, learn 2-way radio, Citizens Band microwaves, and radar.

**5-watt AM  
transmitter/  
receiver**



# NTS Home Training puts you in the lead.

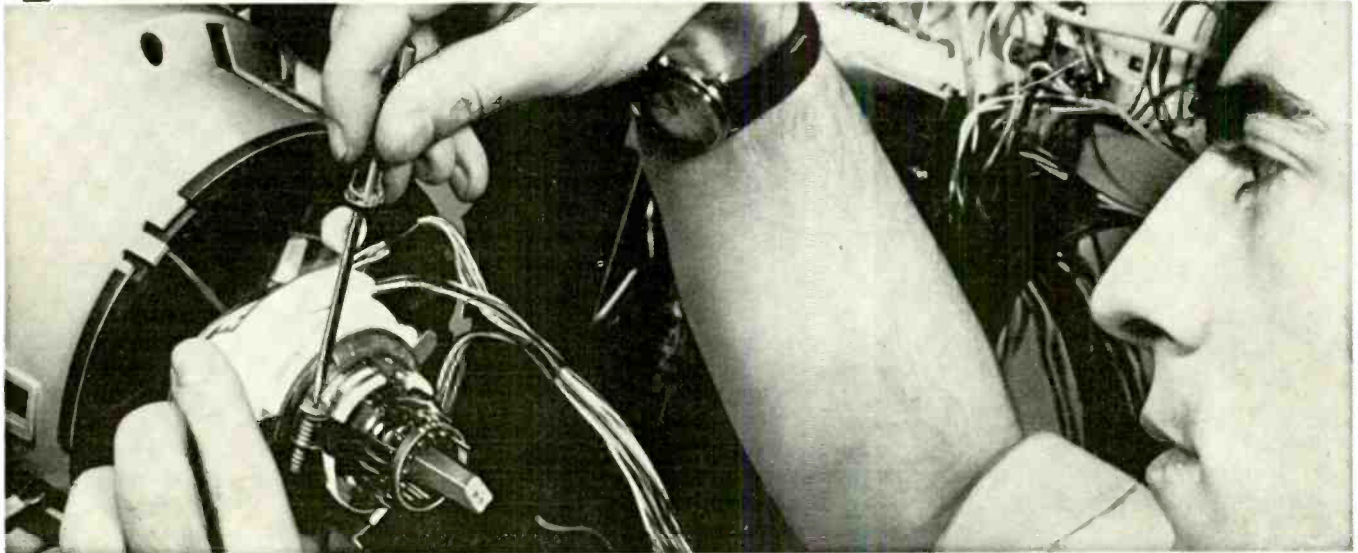

## NTS INDUSTRIAL & AUTOMATION ELECTRONICS

Automation is the future of industry and you can play an important part! Learn industrial controls by training on the NTS Electro-Lab (a complete workshop). You also build and operate this 5" Solid-State oscilloscope. And you perform experiments that involve regulating motor speeds, temperature, pressure, liquid level, and much more. All equipment is yours to keep.



## NTS AUDIO ELECTRONICS SERVICING

Learn basic sound theory—how it works in home radio, car tape

decks, stereo multiplex component systems, and more! Set up a spectacular music system. Learn about



Build and keep this famous Heath Stereo Receiver and Speakers.

sound distortion, amplification and control, loud-speaker baffles, problems of system installation, etc. Included is Volt-Ohmmeter, In-Circuit Transistor Tester, and Solid-State

Radio. Prepare yourself for great opportunities in the Home Entertainment Industry!

## CLASSROOM TRAINING AT LOS ANGELES

You can take classroom training at Los Angeles in sunny Southern California. NTS occupies a city block with over a million dollars in technical facilities. Check box in coupon below.

## NATIONAL TECHNICAL SCHOOLS

WORLD-WIDE TRAINING SINCE 1905  
Resident & Home Study Schools  
4000 S. Figueroa Street  
Los Angeles, California 90037

## APPROVED FOR VETERAN TRAINING

Accredited Member: National Association of Trade and Technical Schools; National Home Study Council.

Big, Colorful NTS Guide to new opportunities in Electronics. Yours FREE!



NATIONAL TECHNICAL SCHOOLS  
4000 S. Figueroa Street  
Los Angeles, California 90037

Please rush me FREE Color NTS Electronics Guide & FREE lesson, plus information on course checked at right. No obligation. No salesman will call.

- MASTER COURSE IN COLOR TV SERVICING
- COLOR TV SERVICING (FOR ADVANCED TECHNICIANS)
- MASTER COURSE IN B&W TV & RADIO SERVICING
- MASTER COURSE IN ELECTRONIC COMMUNICATIONS
- PRACTICAL RADIO SERVICING
- FCC LICENSE COURSE
- MASTER COURSE IN ELECTRONICS TECHNOLOGY
- AUTOMATION & INDUSTRIAL ELECTRONICS
- COMPUTER ELECTRONICS
- BASIC ELECTRONICS
- AUDIO ELECTRONICS SERVICING

Dept. 206-073

NAME \_\_\_\_\_ AGE \_\_\_\_\_

ADDRESS \_\_\_\_\_

CITY \_\_\_\_\_

STATE \_\_\_\_\_ ZIP \_\_\_\_\_

- Check If Interested in Veterans Training under new G.I. Bill.
- Check If Interested ONLY in Classroom Training at Los Angeles

# AMPLIFIER from 4 channel

Connecting a four-channel amplifier so the output as simple as you may think. Performance

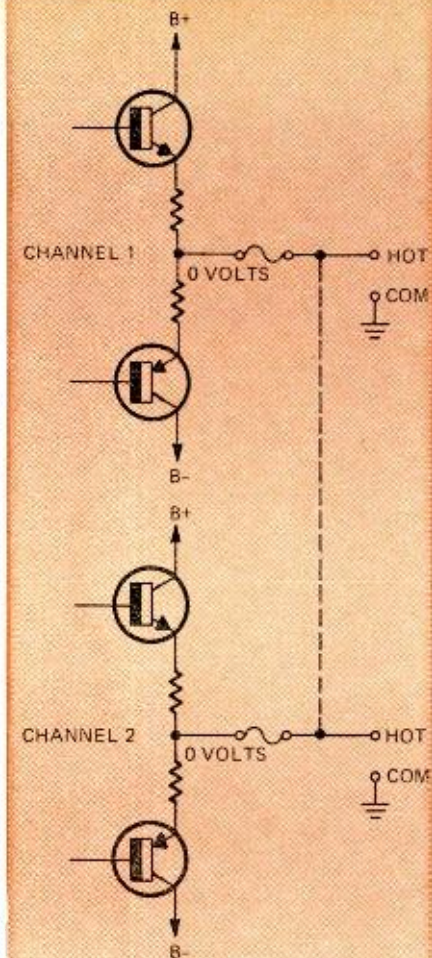

FIG. 1—PARALLELING OUTPUT circuits in solid-state complementary-symmetry arrangements by the brute force method shown (dashed line connection) is not a satisfactory method for increasing power output.

by LEONARD FELDMAN

CONTRIBUTING HIGH-FIDELITY EDITOR

THE VERY FIRST QUADRIPHONIC AMPLIFIERS and receivers that were produced for consumer use two or three years ago were, very simply, "two stereo amplifiers built on one chassis". Admittedly, a few additional controls were provided to tie the system together, but these early controls were confined to regulating low-level signal manipulation and included such new items as FRONT-REAR BALANCE, quadriphonic MASTER VOLUME controls (requiring four ganged potentiometers which would raise and lower all four signal levels simultaneously) and, finally, the popular joystick control, a cleverly assembled mechanical arrangement of coupling members which enabled the user to adjust audio balance in any quadraphonic sense by means of a single stick-shift type lever.

No attempt was made in these early models to use all the available amplifier power in both stereo and quadriphonic modes. Thus, if the user decided to switch to stereo listening, two of the four power amplifier channels remained idle, their inputs grounded and their outputs dis-

connected from the "rear channel" speakers. Alternate arrangements did permit the user to apply the two stereo signals to the rear amplifiers as well as to the front amplifiers on the presumption that "double stereo" (rear speakers reproducing the same program material as front speakers) might be a desirable listening experience. Early users of these first four-channel products quickly found, however, that doubling the stereo was not only inferior to true quadriphonic reproduction but actually tended to confuse the stereo image of sound, giving rise to the "vocalist singing over my head" syndrome.

Unlike the switch from mono to stereo (in which monophonic playback over two speakers often gives a feeling of fuller sound), the switch from quadriphonic sound back to double stereo—just because the extra amplifiers and speakers are available, produced a confusing sound field rather than an improved one.

The present attitude in the marketplace also prompted manufacturers to seek other ways to encourage potential buyers to invest in quadriphonic equipment—even if they weren't quite ready to invest in those extra speakers at the time of initial purchase. Ideally, if there were some way to connect the four power amplifiers for stereo use so that the total power could be combined from four channels down to two, the hesitant buyer could have the best of both worlds. He would use his new electronics in a stereo set-up, with full power available, until he was ready to complete the transition to four-channel sound. At that time two more speakers would be connected, a switch would be thrown, and the doubled-up amplifiers would split into four separate amplifiers.

Direct paralleling of class B power amplifiers, as shown in Fig. 1, is not a practical solution. In the arrangement shown, any slight unbalance between the gains of the two amplifiers involved would result in circulating current between them—current that never reaches the external loads (speakers) and, in extreme cases, could damage the power output transistors themselves, because of the very low internal impedances of such output circuits. It is, in fact, quite common to run across an admonition in stereo amplifier instruction booklets warning users against *ever* connecting the two hot speaker lead terminals together for any reason.

A partial solution to the problem can be seen in Harman-Kardon's new model 50+ receiver, shown in Fig. 2. This receiver, operated in the quadriphonic mode, provides 12.5 watts of continuous power for each of its four channels. When a switch is thrown to the stereo mode, double power (25 watts of continuous power in each of two channels) is available. We call this a partial solution because of the interesting way in which Harman-Kardon accomplishes this feat.

Actually, all four amplifiers remain isolated from each other when the stereo switch position is selected.

As shown in Fig. 3, two amplifiers are completely disconnected from the circuit, with B+ voltage removed from them. The remaining two amplifiers are then supplied with higher operating voltage (B++) and this new "operating point" permits the two operating amplifiers to provide double the power to each of the remaining speaker loads.



FIG. 2—HARMAN/KARDON model 50+ multi-channel receiver.

Although two amplifiers remain idle during 2-channel stereo operation, full use is made of the power supply portion of this receiver, since, in stereo operation, a greater voltage swing occurs across the operating speaker loads, made possible by the higher supply voltage used at that time. Obviously, the output transistors have to be able to operate at the higher 2-channel stereo voltage and, although not shown in the simplified

# SWITCHING to 2 channel

*circuits work in pairs into stereo speakers is not often suffers. Here's how the pros do it.*

diagram of Fig. 3, bias and other operating point parameters must be switched as well.

## Strapping or bridging circuits

A more complete solution to the problem of power utilization was used in the rest of the Harman-Kardon *plus* series of multichannel receivers. Other models include the 75+, the 100+ and the powerful 150+ model. The idea of strapping amplifiers properly for increased power is actually not new, having been discussed in an engineering paper written by Bell Laboratories some years ago. Harmon-Kardon was probably the first to use the principle in a consumer product. However, since the introduction of this line of receivers, many other manufacturers have come up with similar products, though circuits vary somewhat between manufacturers.

The model 75+ is pictured in Fig. 4 and a simplified diagram of the switching arrangement is in Fig. 5. To understand the principle of operation, Fig. 5 has been further broken down into Figs. 6-a and 6-b. In Fig. 6-a, a front and rear amplifier are shown, each connected to a speaker load with a conventional "ground" return for each circuit. One of the two channels, however, is equipped with an extra transistor stage, hooked up as an emitter follower in the case of Fig. 6-a.

Under these conditions, the gain of the emitter follower stage is very nearly unity, and the phase of the input and output signals from this stage is identical. The phase relationship of the two power amplifier outputs is, therefore, also "in phase". Only two amplifiers are shown in Fig. 6-a, corresponding to, say, the left-front and left-back channels. Another pair of similarly connected amplifiers would be used to power the right-front and right-back speakers.

Referring now to Fig. 6-b, for stereo use, the extra stage is now used both as an emitter follower and as a phase inverter, since the output signal taken from the collector load of the transistor will be 180° out of phase with the input applied to the base. The two power amplifier modules are now fed identical amplitude, out-of-

phase signals, as shown by the sine-wave representations. Switching at the outputs of the two power amplifier sections is so arranged that the loudspeaker is connected between the two former "hot" terminals of the two amplifiers and there is *no* ground return as far as the audio signal is concerned.

Considering the phase and amplitude relationships of the output sine-waves shown, it is clear that the instantaneous potential across the loudspeaker terminals is exactly *twice* the previous amplitude. That means that the rms value of voltage is also twice as great as was the case for a single amplifier operating with a referenced ground return, as in Fig. 6-a. As an example, if the amplifiers operating separately each produced 8 volts rms across their respective 8-ohm speaker loads in Fig. 6-a, then the rms voltage of the combined amplifier pair would, in theory, be 16 volts. Translated to power, the first case would represent 8 watts of power in each speaker load ( $P = E^2/R_L = 8^2/8 = \text{watts}$ ) whereas in the "strapped" case,  $P = 16^2/8 = 256/8 = 32 \text{ watts}$ —actually *four times* the output power of each amplifier operating singly.

In actual practice, the resulting power works out to be something less than four times single-channel power, but *greater* than double power. This is because of the change that takes place in the output impedance of the system, internal impedance discrepancies, and power supply limitations. In the

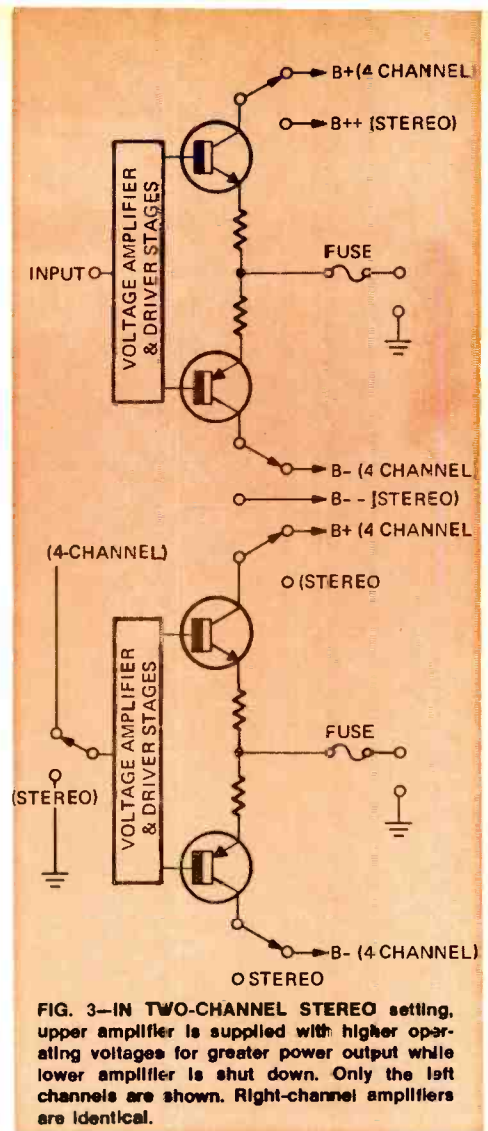

FIG. 3—IN TWO-CHANNEL STEREO setting, upper amplifier is supplied with higher operating voltages for greater power output while lower amplifier is shut down. Only the left channels are shown. Right-channel amplifiers are identical.



FIG. 4—HARMAN/KARDON model 75+ twin power multichannel receiver.

case of the H-K 75+, for example, "quadriphonic" power is 18 watts for each of the four separated channels, whereas when the "strapping" arrangement is selected, power output is

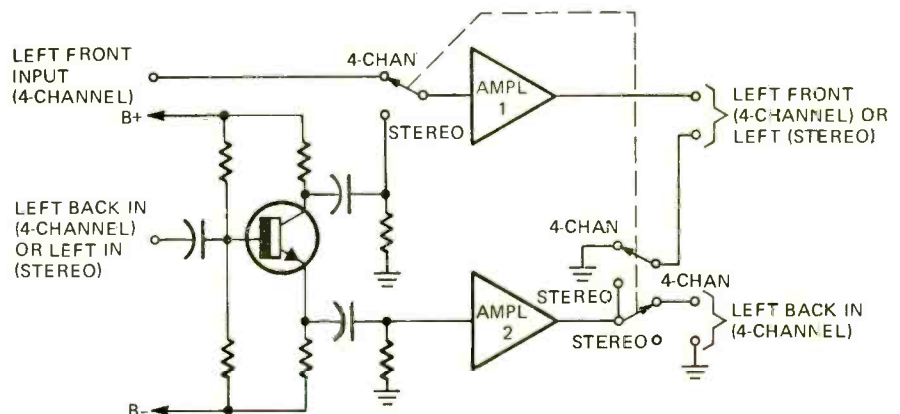
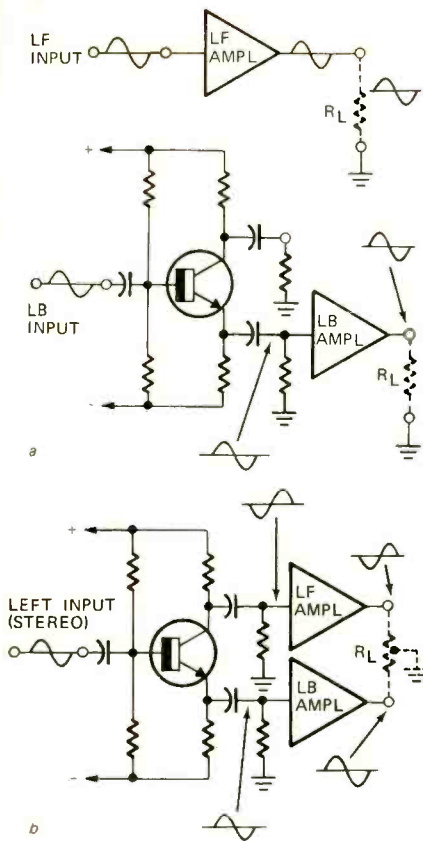

FIG. 5—SIMPLIFIED BLOCK DIAGRAM of stereo/quadriphonic switching arrangement used in Harman/Kardon receivers. Only the left channels are shown to simplify the diagram.



**FIG. 6—IN FOUR-CHANNEL USE** (a) both amplifiers produce separate in-phase signals if both input signals are in phase. In stereo use (b) a single input produces two out-of-phase output voltages that are connected at the opposite ends of a single load. Note position of phantom ground at mid position of speaker load  $R_L$ .

45 watts for each of the "new" stereo channels, considerably more than twice the single channel value, but not equal to the theoretical maximum of *four times a single channel*.

The "strapping" circuit effectively places the two amplifiers of each stereo channel in *series* in Fig. 6-b, and the phase inverter is required to produce two output signals that are *additive* rather than subtractive. Readers familiar with the very earliest Dynaco hook-up for three-channel stereo (when multiple channel arrangements beyond stereo were first being investigated) will recall that Dynaco said place a third speaker at the rear of the listening room and connect it to the two "hot" terminals of a conventional stereo amplifier.

The signal fed to the third speaker would then be left - right ( $L - R$ ), or so-called "ambience" in-

formation in most stereo discs.

The present strapping arrangement differs in two ways. First, we are dealing with two *equal* signals, applied to two equal amplifiers. If those signals are called "L", the results of the Dynaco hook-up would be total cancellation, or  $L - L = 0$ . By phase inverting one of the two inputs, the resultant signal simply becomes,  $(L - (-L)) = L + L = 2L$ .

### A slightly different approach

Fisher Radio introduced a series of dual-purpose receivers shortly after the announcement by Harman-Kardon. Known as the *Studio Standard* series, the three models offered the same stereo/quadrasonic flexibility as did the H-K units. A photo of the Model 404 is shown in Fig. 7, and since all three models perform the strapping function in a similar fashion, we have excerpted portions of the schematic diagram of the top-of-the-line Model 505 to explain the differences in approach between the two manufacturers. Fig. 8-a is a block diagram of the four power amplifiers, as they are connected to the "main"

**FIG. 8—SPEAKER JUNCTION SWITCH** on front panel of Fisher 504 is shown in 4-channel arrangement (a) and 2-channel setting (b). Additional contacts for choosing main, remote or phones have been omitted for clarity.

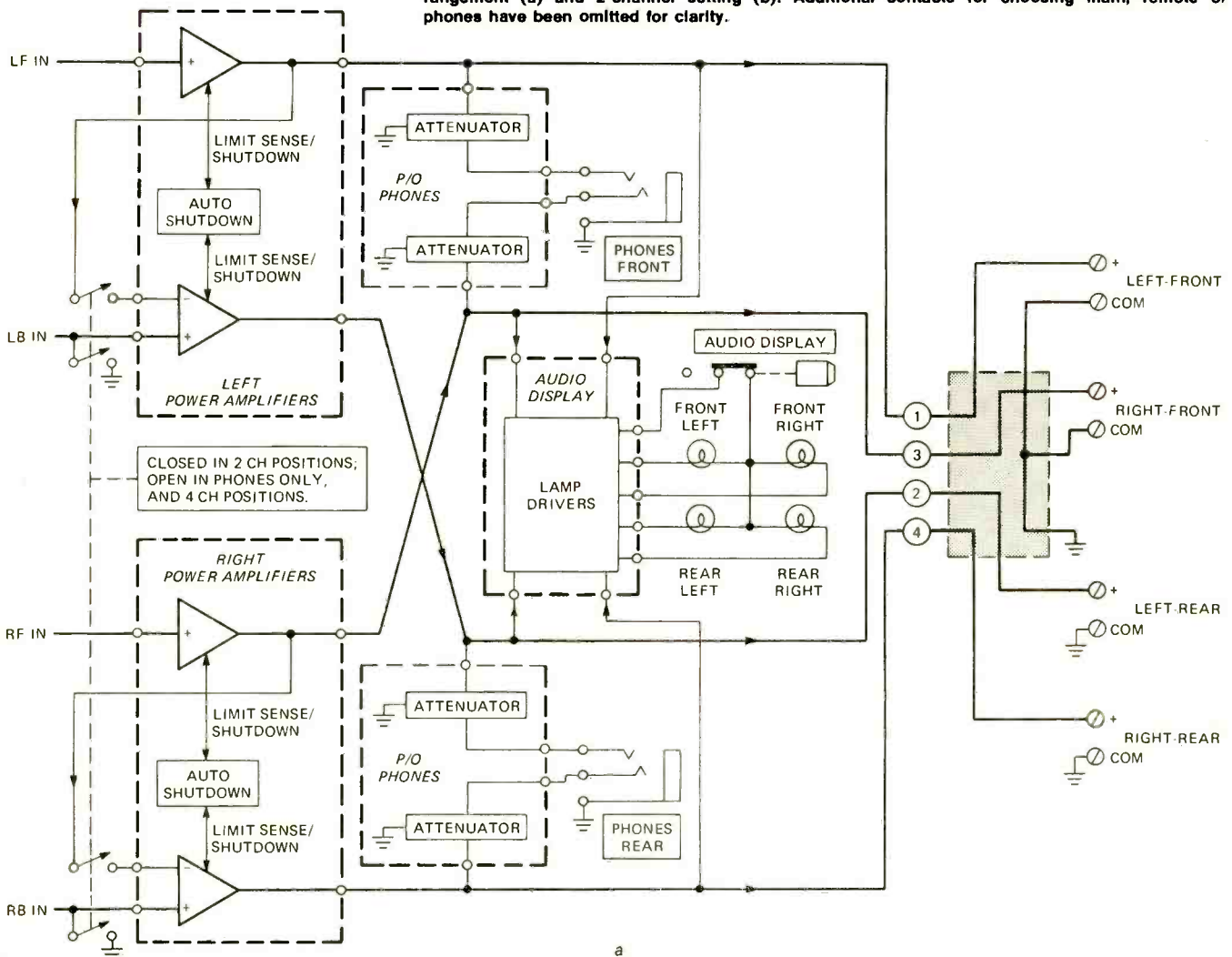



**FIG. 7—FISHER RADIO model 404 convertible stereo receiver with SQ decoder.**

speaker loads for quadraphonic use. Each amplifier operates separately and each speaker load has a conventional "ground" return. In Fig. 8-b, a switch has been thrown to strap the amplifiers together in pairs. As before, each pair of amplifier outputs ends up in series, and there is no ground return reference. The phase-inverter stage is noticeably absent, however, because the required out-of-phase signal for application to the lower amplifier block is derived from the output voltage of the *upper* amplifier.

The lower amplifier inputs now grounded by a section of the STEREO/FOUR-CHANNEL switch and a new input connection to the lower

amplifiers is made by the line from output **A** to input **B**. At first glance it would appear that the lower amplifier input in each pair is being grounded out by the switch sections shown, but if you were to examine the full amplifier schematic of a dual amplifier module you would note that the actual input stage of each module takes the form of a differential amplifier which has *two* available inputs. The LBIN and RBIN inputs are used for quadraphonic operation, whereas for stereo strapping, these inputs are grounded, and the alternative inputs (See Fig. 8-b below) are used to handle the signal inputs.

There is another difference between the H-K approach to amplifier strapping and that of Fisher, which represents a difference in sales philosophy more than one of circuitry. Harman-Kardon elected to place the 4-channel/2-channel switch on the rear panel of their receivers. The implication is that a user will probably start by purchasing the receiver and two speakers and will at first keep the slide switch in the "2-channel" position. Then, at some future date, the

user may buy two more speakers and will move the switch to the 4-channel position—leaving it there forevermore, as a "one-time" change in operating mode.

Fisher Radio evidently felt that the user may, for reasons of his own, wish to revert to two-speaker playback from time to time, even after he has added the extra speakers needed for a full quadraphonic array. Accordingly, Fisher elected to incorporate the switching as an integral part of its usual SPEAKER SELECTOR switch.

In fact, Fisher's Speaker Selector switch has positions for MAIN, REMOTE and MAIN + REMOTE for 2-channel operation, and three more similarly denoted positions for 4-channel operation—a total of six positions—plus a seventh PHONES ONLY position. Since phones require minimal audio power, Fisher operates the four amplifiers independently again, when the switch is in the PHONES ONLY position. The user then has the option of connecting either (2 channel) stereophones (to the front phones jack) or (4 channel) quadraphonic phones (to both front and rear phone jacks). **R-E**

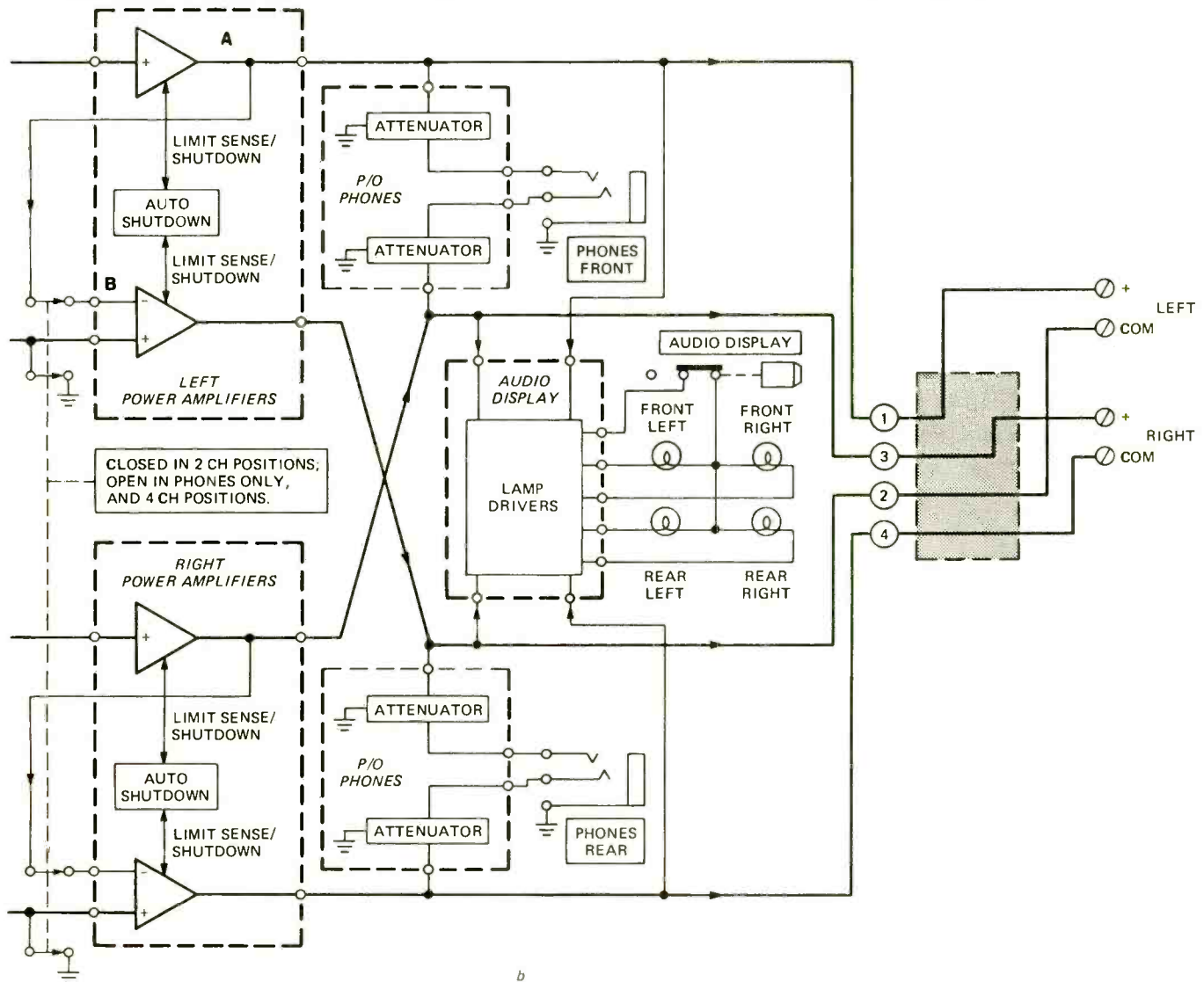

# equipment report

## Lesco Multitracer

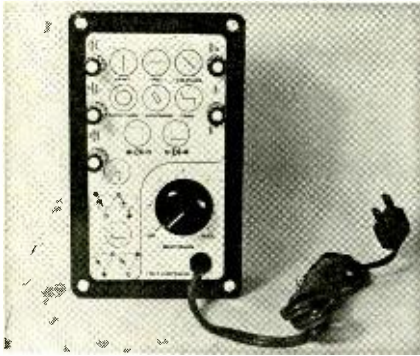

Circle 76 on reader service card

LESCO ELECTRONICS, OF CHICAGO, has brought out an interesting little black-box tester for solid-state devices, plus other parts. Used with any standard oscilloscope, it will display distinctive patterns for a great many common semiconductor devices; transistors, diodes, Zeners, and even capacitance and inductance. This is not a curve-tracer displaying the family of curves, but a "Quick-Tester" for finding and identifying defective parts in a hurry.

Connections to the scope are simple; ground, external horizontal input and vertical input. When the test leads are shorted, a vertical line appears. If the device is open, all you see is a horizontal line. The scope gain controls are adjusted to make both lines of the same length. After this, any variations can be made with the adjustable POWER CONTROL on the Multitracer. This limits the power applied to the device to only a few milliwatts, for safety.

By connecting the test leads across a diode, an angle pattern is seen, if it's a good diode. The position of the angle tells you which test lead is on the anode, or cathode; a handy check for those unidentified rectifiers, etc. A capacitor, in or out of circuit, makes a circle. This is limited to medium-sized capacitors, but it's very handy when hunting for open bypasses. Inductances, if small, make a vertical line, since the test power applied is at 60 Hz. Some will show a hysteresis loop, squarish.

One handy use for this is identifying transistors as silicon or germanium. With a completely unknown transistor, you simply keep trying dif-

ferent pairs of leads until you see one of the distinctive patterns in the diagram. If all you can get is vertical lines, the transistor's shorted; horizontal lines, it's open. Interestingly enough, you get the zig-zag pattern with the test leads reversed.

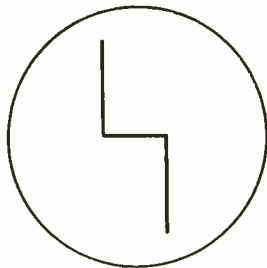

SILICON

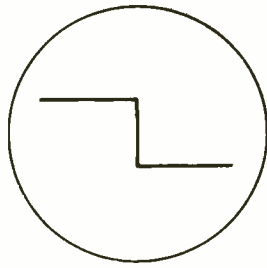

GERMANIUM

If it's a silicon transistor, the test leads are on the base and emitter; the collector is the open lead. If it's a germanium, you're on the collector and emitter; the base is the open lead. One more simple test, and you'll know which one of the two leads you're hooked to is which.

Transistor leakage is shown, out of circuit, by a slant of the vertical lines in the zig-zag pattern. Silicon transistors should show no slant. Germaniums will always show some slant. A little practice will help you tell how much can be tolerated.

All in all, this is quite a versatile little black box. For its \$19.95 price, a handy addition to your solid-state test equipment. I tried it out on my box of known bad transistors, and on new ones of all types and sizes. After learning how to use it, by taking the unusual step of reading the instruction manual, I got along fine. For convenience, the typical patterns you'll see are printed on the panel, and the bottom, of the Multitracer cabinet. All connections are plainly marked. **R-E**

## Kandu PC Kit

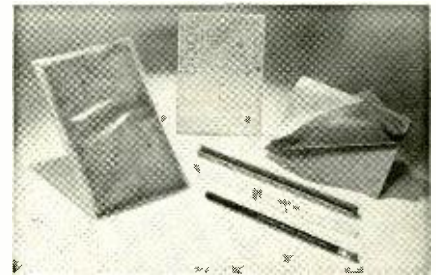

Circle 77 on reader service card

THE EDITOR GAVE ME A LITTLE BOX, AND said "Try this out!" It turned out to be a printed-circuit kit, called "Kandu" made by the Kenneth A. Norris Development, Unltd., Inc., 6115 Miller St., Arvada, CO, 80002. In the box was a sheet of nice heavy epoxy-glass copper laminate, a template for drawing all kinds of patterns, and even a pencil. A heavy double plastic bag contained the etchant, ferric chloride, in dry form.

The epoxy laminate, 4x6 inches, had three thin sheets taped to one edge. These turned out to be a protective sheet, a sheet of acid-resist and a sheet of very thin plastic. To make the first step, you slip the PC board pattern you want under the top sheet, pull out the protective sheet, and trace the pattern.

I picked out an easy PC pattern, cut it out, and taped it firmly in place, as the instructions said. Then, I traced it. You trace the parts you want to leave; in other words, the conductors, pads, etc.

Now you mix the etchant. Just cut the end off the bag, pull out the inner bag and cut it open, slip them together, and pour in a cup and a half of hot tap water. Hold the bag tightly closed and agitate it until all of the powder is dissolved (and don't slop it!).

Now, peel the other sheets off the PC board, and slip it inside the bag. A special plastic bag-lock holds it shut. (Rubber gloves and a thick apron are recommended for this part.) Now, agitate the bag gently and wait. You will see it go to work eating off the unwanted copper. Leave the board in the bag until the unwanted copper is gone.

After etching, rinse the board in warm water, then scrub it with kitchen cleanser and steel wool.

If you follow the directions carefully, you can make up pretty nice looking PC boards with this kit. Not at all difficult, if you're careful. **R-E**



# 8 ways to test HI-FI amplifiers

FIG. 1—TYPICAL TEST SETUP shows all equipment placed on a copper sheet that serves as a common ground to minimize ground loops that lead to the development of induced hum and feedback.

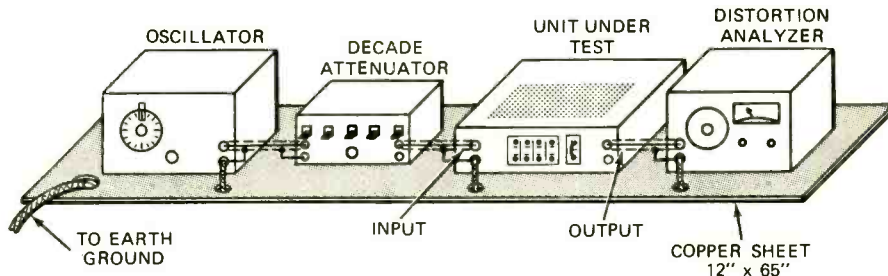

*Test and maintenance of hi-fi equipment requires special equipment and special techniques. Here are eight steps for the complete check-out of hi-fi amplifier systems.*

by EDWARD C. PALMER

THE SECRET TO KEEPING A HI-FI amplifier at its peak is a set of testing procedures that will accurately tell how well the amplifier is performing. This series of test procedures should be performed by the technician every time he repairs a hi-fi amplifier. It is not enough to fix the trouble the amplifier was brought in for. He must also insure that the amplifier is delivering all of the quality that was built into it.

When it comes to amplifiers, there are eight specific tests that act as a proper guide to amplifier performance. They are:

1. **Continuous (rms) power output vs. distortion.**
2. **Harmonic distortion vs. output voltage (for preamps).**
3. **Output vs. intermodulation distortion.**
4. **Power bandwidth.**
5. **Sensitivity.**
6. **Damping factor.**
7. **Signal-to-noise ratio.**
8. **Frequency response.**

In this article we will describe each of these eight tests, the equipment to use when making them, the set-up for the tests and the procedures to follow when conducting them. But before we go into these tests, let's take a look at the test equipment you should be using.

*Remember:* the better the test gear, the more accurate the test and its results. In the paragraphs that follow, we mention equipment and its recommended specifications. The closer your gear comes to these recommendations, the more accurate your tests will be.

## Test equipment

The ac voltmeter is a must. Generally, the distortion analyzer you use

will contain an ac voltmeter. This voltmeter can be used for all the tests in this article except the damping factor. When measuring damping factor, a five-digit DVM is needed.

The audio generator is another vital cog. It should have an output impedance of 600 ohms or lower and the distortion level in the generator output should be less than 0.01% from 5 Hz to 100,000 Hz. Frequency accuracy should be within 2% of the indicated dial reading.

A harmonic distortion analyzer is also a must. It should be capable of measuring the total of residual hum noise and distortion components of any sinewave signal between 10 Hz and 100,000 Hz to an accuracy of  $\pm 5\%$  or better of full scale.

The intermodulation analyzer you use must provide 60 Hz and 7,000 Hz test frequencies in the amplitude ratio of 4:1 for IHF-rated equipment. The output level of the combined signal should be at least 1 volt into a 10,000 ohm load. The distortion measuring circuit should require an input voltage no greater than 0.9 volt and should present an input impedance of slightly more than 50,000 ohms. The full-scale sensitivity on the lowest range of the analyzer should be 0.3% or better and the accuracy should be better than less than 0.01% when driving a 10,000 ohm load.

The attenuator should provide at least 80 dB attenuation, preferably 100 dB in six increments of 0.1 dB. Attenuation accuracy should be 1% or better over the entire frequency range of 0 to 500,000 Hz. The input and output impedance of the attenuator should be 600 ohms and since the output of the attenuator will be connected to high impedance (greater than 50,000 ohms) input sources, you should terminate the output of each attenuator with a 600 ohm 1% non-in-

ductive resistor.

Use an oscilloscope with a vertical channel frequency response of at least 10 Hz to 200,000 Hz  $\pm 3$  dB. Most service scopes and virtually all high-quality scopes are suitable.

Load resistors are needed to terminate the output of power amplifiers. They should be 8 ohms  $\pm 1\%$  and should be a resistive load that does not have more than 2% reactive component at any frequency up to 1.5 MHz. The load should be capable of continuously dissipating the full output of the amplifier while maintaining its resistance within 1% of its rated value. For stereo amplifiers, two such load resistors are required. When testing preamplifiers, the output terminals should be terminated with 100,000-ohm 5%  $\frac{1}{2}$ -watt resistors shunted by approximately 100 pf.

## Low level measurements

Ac power connections, grounding the amplifier under test and the test equipment used in these test procedures can be critical. To measure low levels of distortion, the hum and noise components of the test signal must be held to extremely low levels. However, this is difficult to do when the voltage gain of the circuits being measured is very high and the level of amplifier output signal in which the distortion measurement is being made is low.

This combination of factors makes the entire test set-up readily susceptible to external ac fields and ground loops. So much, in fact, that the hum and noise appearing in the output signal may be several times higher than the actual distortion components and noise generated by the amplifier being tested. The result is that it is extremely difficult to obtain distortion readings below the reference distortion levels for high-gain preamp inputs (such as phono and tape head)

when the unit is operated wide-open.

The solution is to apply a signal to the high-gain inputs about 30 dB higher than their reference sensitivity level and use the preamplifier volume control to set the output voltage across the reference load. This technique provides an extremely good signal-to-noise ratio at the low-level portion of the test set-up.

Hum pick-up via ground loops can be minimized by using a copper sheet as the ground return between ac-operated equipment (see Fig. 1). Each ac-operated item is connected to the copper sheet through a short length of heavy copper braid. Note that the shield around the hot signal lead is connected to the equipment at one end only. Thus the shield serves only as a shield.

The copper sheet acts as a low-impedance ground return for the signal. The attenuator has no power line connection so it can be connected to the generator in a normal manner. Power-line leakage current from the power transformer primaries to ground can be reduced by reversing the power plugs of the ac-operated equipment until the lowest amount of system hum results.

### Rms power output vs. distortion

For this test, we determine the largest single frequency power output obtainable from an audio power amplifier with a sinewave input signal for a substantial length of time at reference distortion and the total harmonic distortion resulting when an audio power amplifier produces a specific power output. Set up is in fig. 2.

Amplifier controls for this test as well as the others described in this article are set so that the volume or level control whose primary function is adjusting gain are set for maximum gain. Tone, loudness and other controls whose primary function is to adjust the frequency response are preset for flat electrical response. Controls such as balance are set to their normal position. If there is a mode selector, make sure it is set to stereo and make sure that the function selector is set to match the input being used.

To make a distortion measurement at a single power level, adjust the attenuator to produce a voltage across the amplifier load corresponding to the rated power level of the amplifier. Then measure and record the distortion in the amplifier output signal.

To make a full series of power outputs vs. distortion measurements, adjust the attenuator to produce a voltage across the reference loads corresponding to a power level of 1% of the rated power output of the amplifier.

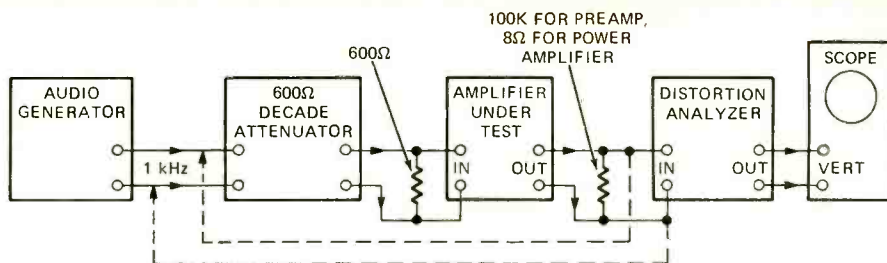

FIG. 2—TYPICAL INSTRUMENT SETUP used for a number of the tests required to service and maintain high-fidelity equipment. The circuit load differs with preamps and power amplifiers.

Then make the distortion measurement. Next increase the power to the next desired step and take another measurement. Record the voltage across the reference loads and the distortion readings resulting each time. Make each measurement with the input signal applied for a period of not less than 30 seconds.

Plot the results of the measurement on log graph paper as shown in Fig. 3. The power output is expressed

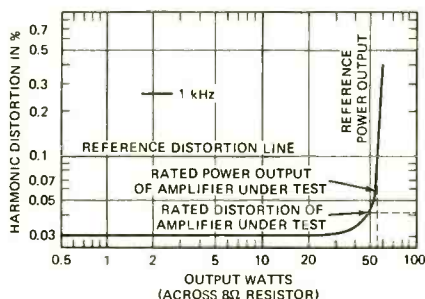

FIG. 3—HARMONIC DISTORTION is plotted against power output across precise load.

in watts and the distortion in percentage.

### Harmonic distortion vs. output

This test measures the percentage of total harmonic distortion generated by audio voltage amplifiers supplying their rated output voltage and shows how to determine the largest undistorted output voltage available from a voltage amplifier or preamplifier at reference distortion into a specific load. Use the equipment set-up shown in Fig. 2. It is desirable to display the output of the distortion meter on an oscilloscope so that hum, noise and the various distortion components may be seen.

To measure the total amount of harmonic distortion occurring at the reference output voltage level, adjust the attenuator to produce the output voltage across the reference load equivalent to rated power output of the amplifier.

When measuring distortion with the signal applied to phono, mike or tape head input, adjust the attenuator to produce the input voltage required by the preamp and adjust the amplifier volume control to produce its rated output. Measure and record the

distortion in the amplifier output signal. This distortion is measured at the reference output voltage and is the rated distortion.

To make a full series of output voltage vs. distortion measurements, adjust the attenuator to produce the voltage across the reference load corresponding to 10% of the reference output voltage. When measuring distortion with a signal applied to phono, mike or tape head input, adjust the attenuator to produce the input signal level desired and adjust the amplifier volume control to set the voltage across the reference load that indicates the amplifier is operating at its rated output. Measure and record the distortion in the amplifier output signal.

Then readjust the attenuator to increase the voltage across the reference load resistor and measure the distortion again. Make an appropriate number of distortion measurements at various output voltages up to the level that exceeds the rated distortion of the amplifier. Record the voltage across the load and the distortion reading resulting each time. A typical harmonic

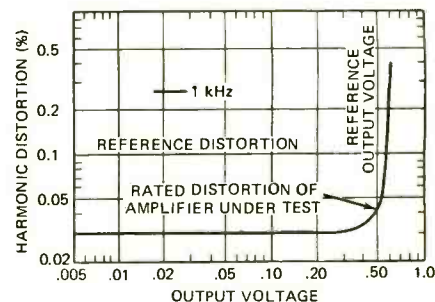

FIG. 4—DISTORTION IN PREAMPS is measured with output across specified load.

distortion vs. output voltage chart built up in this way is shown in Fig. 4.

### Output vs. IM distortion

This test measures the percentage of intermodulation distortion at rated output power. Set up the equipment as shown in Fig. 5. Set gain, level and any other controls whose primary function is adjusting gain to the position of maximum gain.

To perform the test, adjust the output signal of the IM analyzer to produce the voltage across the load

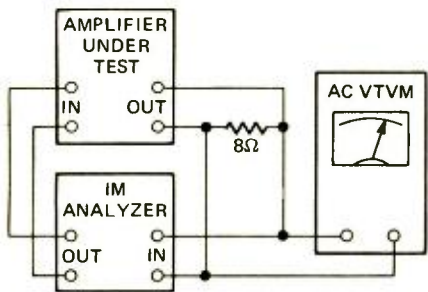

FIG. 5—IN IM DISTORTION TESTS the distortion analyzer develops test signals.

that is equivalent to 1% of the reference power output. Measure and record the distortion produced at this level. Then readjust the IM analyzer output to increase the voltage across the load resistor. Again record the output level voltage and the resulting distortion. Make several distortion measurements up to the output voltage level equivalent to full-rated output of the amplifier. If desired, you can plot the results of these measurements as in Fig. 6 and see how the in-

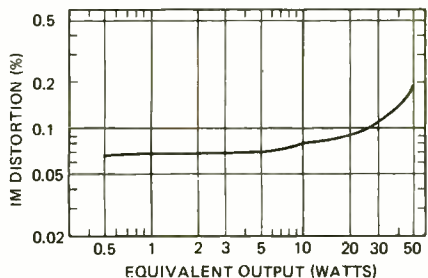

FIG. 6—IM DISTORTION CURVE. Compare it with the THD curve in Fig. 3.

termodulation distortion varies with power output. Power output should be in watts and the distortion in percent.

### Power bandwidth

This test is used to determine the power bandwidth of an amplifier with a continuous sinewave input signal. For high-fidelity test purposes, the rated power bandwidth of the power amplifier is defined by the two frequencies where the distortion at a power level 3 dB below reference output exceeds the mid-frequency reference distortion.

The test set-up for measuring power bandwidth is shown in Fig. 2. It is convenient to display the output of the distortion meter on the scope so that hum, noise, and other distortion components may be distinguished. Controls should be set as in the previous tests.

Measure the power output of each channel. The other channel must be either driven to approximately the same power output or not driven at all. Set the audio generator frequency to 10 Hz and its output amplitude to about 2 volts. Measure and record the distortion in the generator output sig-

nal. Reconnect the distortion analyzer across the load resistor.

Adjust the attenuator to produce the voltage across the load corresponding to a power level 3 dB below the amplifier's rated output power. Record this reading from the distortion meter while maintaining a constant output voltage across the load. Measure and record the residual distortion of the test equipment and the total distortion at each of the following frequencies: 12, 15, 20, 30, 50, 100, 200, 500, 1,000, 2,000, 5,000, 10,000, 20,000, 30,000, 50,000, 70,000 and 100,000 Hz.

If necessary, make additional measurements around the point at which the distortion suddenly begins to increase. Plot the results on log paper as in Fig. 7. Don't bother plotting

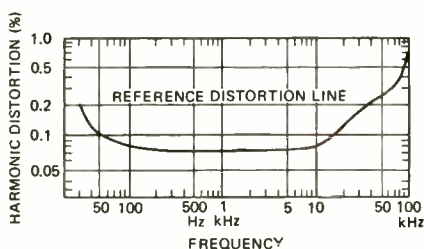

FIG. 7—HARMONIC DISTORTION rises at the low and high ends of amplifier's passband.

results at frequencies that produce distortion figures greater than five times the reference distortion. The two frequencies at which the resulting curve of output and distortion vs. frequency intersect the reference distortion line define the limits of the power bandwidth of the amplifier under test.

### Sensitivity measurements

This test measures the minimum input voltage which, when applied to the terminals of an amplifier operating under standard test conditions, will develop a reference output. Set up the

equipment for this test as shown in Fig. 8. Again, it's handy to display the output of the amplifier on the scope to insure that the amplifier is not being overdriven. Reverse the line cord if necessary for minimum hum on the highest gain input. Connect the attenuator input.

Once the equipment is set up, first set the audio generator to 1,000 Hz. Then adjust the generator output amplitude to produce the voltage across the load that corresponds to the amplifier's rated output. Record the input voltage to the amplifier. Then repeat this measurement for each set of input terminals. Again, record the input voltage each time and the marking of the terminals at which it was measured.

### Damping factor

In this test, we measure the ratio of the output voltage of the amplifier operated under load to the measured output voltage change when the load is removed. Damping factor measures the regulation of the amplifier and is also an indirect measure of the output impedance of the amplifier. The equipment set-up for measuring damping factor is shown in Fig. 9. Remember: for this test, you should use a five-digit DVM. Control settings of the amplifier are the same as in the earlier tests.

The rated damping factor is measured at 1,000 Hz at the rated power output. Regulation is the inverse of damping factor and is expressed in percent. When the test equipment and amplifier is set up as in Fig. 9, set the audio generator to 1,000 Hz and then adjust the generator output amplitude to produce the voltage across the reference load corresponding to reference output power. Record this voltage accurately. Then disconnect the reference load and record the voltage at

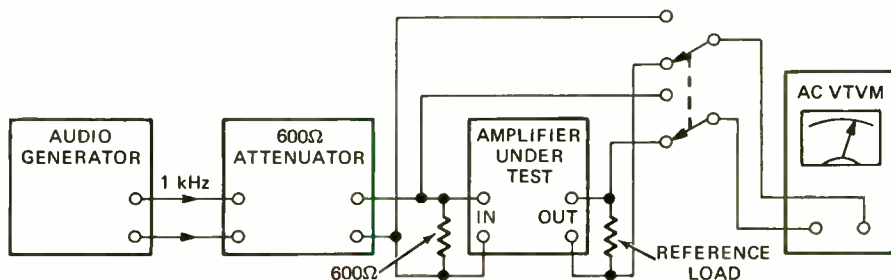

FIG. 8—SENSITIVITY MEASUREMENTS determine the signal level required to drive amplifier to predetermined reference level. Use scope to insure against overdriving amplifier.

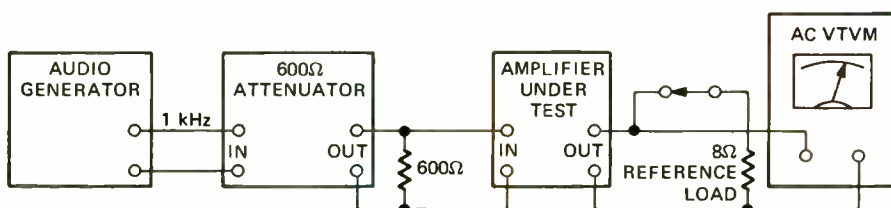

FIG. 9—DAMPING FACTOR determines how amplifier performs as load impedance varies between infinity and rated value. It is measured with 1 kHz input driving amplifier to rated output.

the output terminals of the amplifier. Next, calculate the damping factor using the formula:

damping factor +  $E_L/E_{NL} - E_L$   
 where  $E_L$  equals amplifier output voltage under load and  $E_{NL}$  equals amplifier output voltage with load disconnected.

If desired, damping factor can also be measured between 20 and 20,000 Hz to determine the effect of

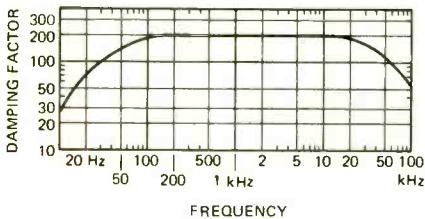

FIG. 10—DAMPING FACTOR CURVE showing effect of frequency on amplifier's performance.

frequency. Results of such a measurement should be plotted on log graph paper as shown in Fig. 10.

### Signal-to-noise ratio

This test measures the signal-to-noise ratio of the amplifier. This ratio depends mainly on hum and noise signals occurring in the amplifier in the absence of an input signal. Hum consists of output signals due to the power line frequency and noise consists of random components distributed in varying degrees throughout the measurable frequency range.

With the test equipment and the amplifier under test connected as shown in Fig. 11, start off by shorting all input terminals of the channel

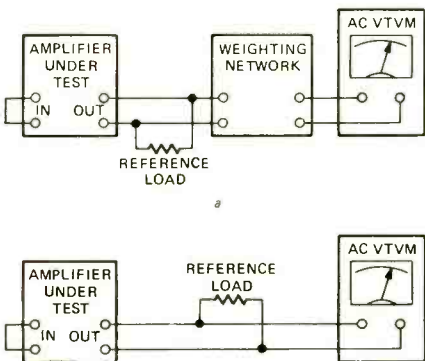
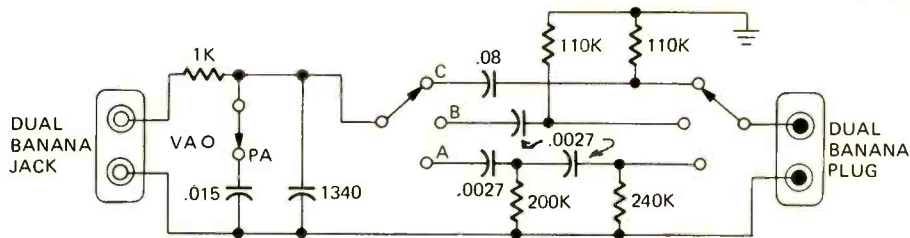

FIG. 11—SIGNAL-TO-NOISE measurements with weighting network (a) and without (b).

whose hum and noise output you are measuring. Be sure that the shorting connections do not act as pick-up links for magnetic hum fields generated by the amplifier or the test equipment. Use the weighting network shown in Fig. 12. The rated wideband signal-to-noise ratio of the amplifier is the ratio of the amplifier's rated output to hum and noise output of the amplifier and is expressed in decibels.



VA = VOLTAGE AMPLIFIER POSITION  
 PA = POWER AMPLIFIER POSITION  
 FIG. 12—WEIGHTING NETWORKS FOR S/N measurements. Network C rolls off at 6 dB/octave at 20 and 10,000 kHz. B changes C's response by same amount as R-C network with half-power point at 160 Hz. A changes C's response by same amount as two cascaded R-C networks with half-power point at 260 Hz.

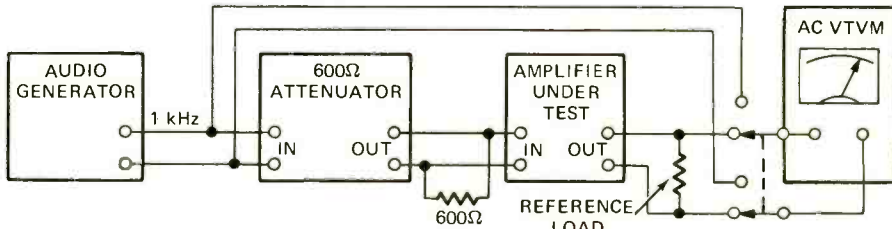

FIG. 13—EQUIPMENT SETUP FOR FREQUENCY RUNS. Switching the output meter between the input and output helps you keep the input signal constant at the predetermined level.

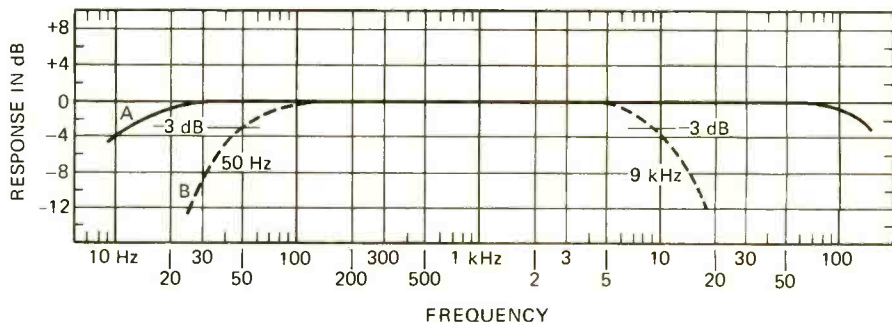

FIG. 14—RESPONSE CURVES of a typical amplifier. Curve A is made with the controls set for flat response. Curve B results when the amplifier's 50-Hz low and 9-kHz high filters are cut in.

### Frequency response

With this test, it is possible to measure the frequency response of an amplifier. Frequency response or, more properly, amplitude response with respect to frequency is the variation (expressed in dB) in the output of the amplifier under test over a particular frequency range with constant amplitude input signal.

When equipment is set-up as shown in Fig. 13; you are ready to start your frequency response testing. Set the audio generator to 1,000 Hz and adjust the generator output amplitude to produce 2.83 volts across 8 ohms for power amplifiers and 0.3 volts across 100,000 ohms for pre-amplifiers. Record these attenuator settings. While maintaining a constant input voltage to the attenuator, set the audio generator in turn to each of the following frequencies: 10, 12, 15, 20, 30, 50, 100, 200, 500, 1,000, 2,000, 5,000, 10,000, 20,000, 30,000, 50,000, 70,000, 100,000, 150,000, 200,000, 300,000 and 500,000 Hz.

At each frequency, readjust the attenuator to maintain the voltage across the load specified earlier. Record the new settings. If necessary, make additional measurements around

the points at which the output voltage suddenly begins to change so that the knees in the frequency response curve can be accurately drawn. Then subtract the attenuator settings recorded in the first part of this procedure from each of the attenuator settings recorded in the second part of this procedure. Plot the resulting dB differences ( $\pm$ ) on semi-log graph paper as shown in Fig. 14.

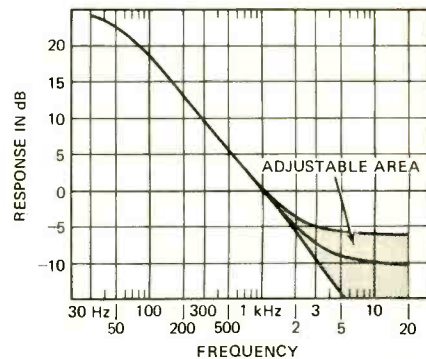

FIG. 15—FREQUENCY RESPONSE of NAB-equalized tape-head input circuit.

The results need not be plotted as frequencies resulting in output voltages greater than 10 dB above or below (continued on page 88)

# Build A Modulated IC Function Generator

One of the most versatile test instruments to be found in an electronics laboratory can now be yours. Three IC's simplify its construction.

by JACK CAZES

HOW OFTEN HAVE YOU WISHED YOU HAD A device for generating a wide variety of waveforms and then remembered that commercially available waveform generators are just out of range of your bank account?

Here's a lab-quality instrument you can build for about \$80 that will do most of the things the expensive waveform generators do. It is designed around a recently developed integrated circuit, the XR-205, which contains three separate functional sections:

- A voltage-controlled oscillator which generates six different basic periodic waveforms;
- A modulator which provides amplitude or phase modulation;
- A buffer amplifier that yields a low impedance output with high current drive capability.

Two XR-205's are used in the waveform generator, one for carrier generation (the six basic waveforms) from 1 Hz to 1.5 MHz, and the other to provide the modulation signal, with a variable frequency ranging from 100 Hz to 150 kHz.

As we shall see later, the waveform generator can be used to produce a variety of waveforms, both amplitude and fre-

quency modulated. Within the capability of this generator are:

- Six basic carrier waveforms, including sine, triangle, square, sawtooth, ramp, and pulse
- Frequency modulation and amplitude modulation
- Sweep generation
- Tone burst generation
- Simultaneous AM/FM operation
- Frequency-shift keyed signals (FSK)
- Phase-shift keyed signals (PSK)
- On-off-keyed oscillation
- Clock generation.

That's right! All of these are switch selectable and their frequencies can be adjusted over the ranges given above.

## Construction is straightforward

The case should be drilled, painted, and marked before starting assembly and wiring. Dry-transfer markings are convenient here, not only for the lettering, but to apply the various dial markings. Several manufacturers offer dry-transfer dial markings for this purpose. Rewire the carrier and modulation frequency switches and mount them on the front panel along with the potentiometers and input/output BNC connectors. Prepare the circuit board ac-

ording to the foil pattern given; then install and solder all components to it. Now orient the circuit board so that IC1 is opposite S3 and IC2 is opposite S2. Connect the leads between these two switches and the board, keeping leads under 2 inches wherever possible. This is done to minimize the possibility of parasitic oscillation.

Complete all of the wiring involving the other panel-mounted components. Use shielded wire for connections to input/output connectors. Finally, wire the power supply according to the schematic given and connect +12 volts and ground leads to the appropriate points on the generator.

## Final adjustments

The two trimmer resistors, R10 and R22, must be adjusted for minimum distortion of the carrier and modulation sine waveforms, respectively. The procedure is as follows:

**Modulation Sine-Wave Distortion Adjustment (R10)**—Set the modulation frequency range (S5) to position 3 (1 to 5 kHz), the modulation waveform selector (S3) to position 1 (Sine), and the modulation mode switch (S4) to position 2 (Off). Adjust R1 for maximum output swing with

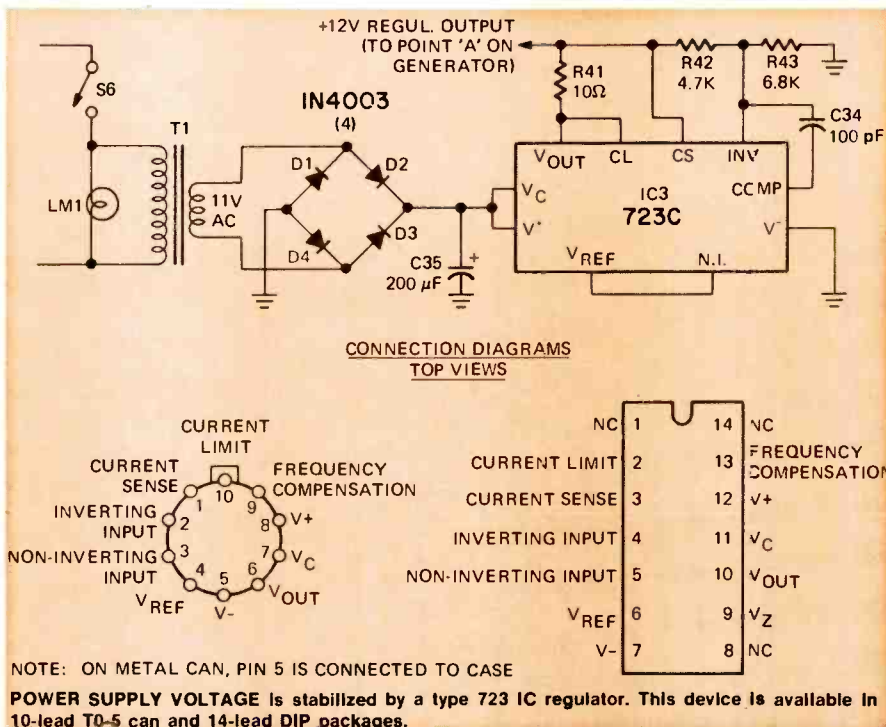
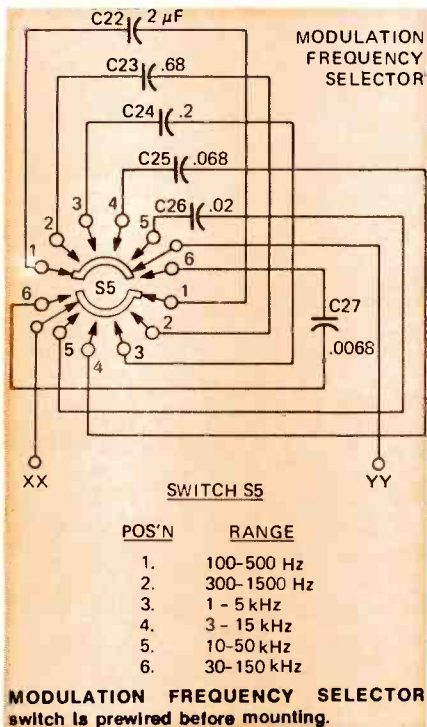

R38 at its midpoint. Output swing should typically be 2 to 3 volts peak-to-peak at point FF on the circuit board or at the modulation output BNC connector. Now adjust R10 to minimize the harmonic content of the waveform. You'll note that, for very large values of R10, the waveform is triangular, and for very small values of R10, the peaks are clipped and the waveform resembles a square wave. Adjust R10 for an intermediate setting between these extremes. This should be done either with an oscilloscope or a distortion analyzer. The "best" setting of R10 should provide a waveform with about 2.5% distortion.

**Carrier Sine-Wave Distortion Adjustment (R22)**—Set the carrier frequency range (S1) to position 7 (1 to 5 kHz), carrier waveform (S2) to position 1 (sine), and modulation mode (S4) to position 2 (Off). Set R6 for maximum carrier output voltage, and R33 for maximum signal output amplitude; position R31 at about its midpoint setting. A 2 to 3-volt peak-to-peak signal should be observed at the output (point Z on the board, or at output connector J1.). Adjust trimmer R22 to minimize the harmonic content of the carrier output waveform just as you did for the modulator out-

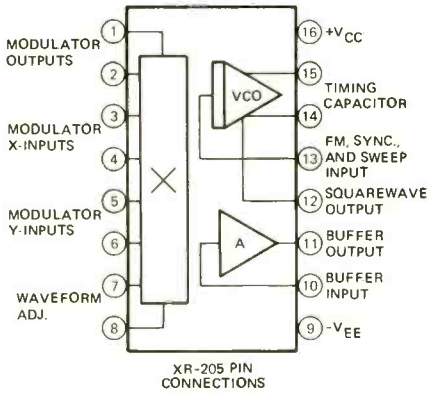

**FUNCTIONAL DIAGRAM** and pin connections for the XR-205. Two are used.

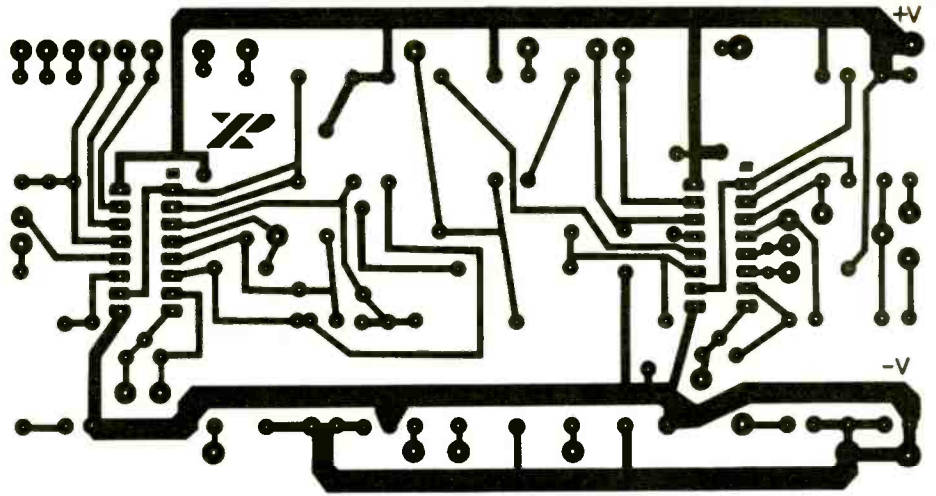

**FOIL PATTERN** for the main circuit board. You can use it to etch your own or you can buy a board from the source listed in the parts list. The board measures 9.9 by 5.4 inches.

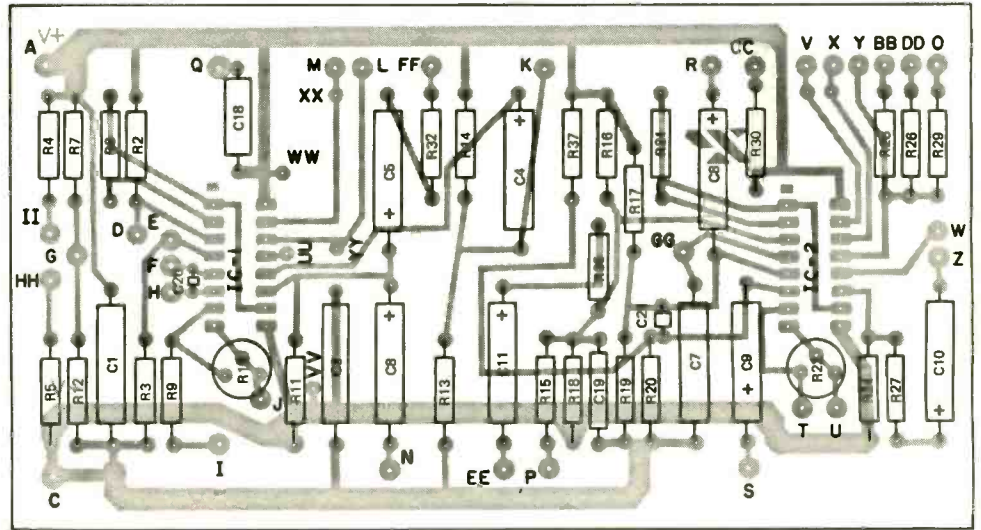

**LOCATION OF CIRCUIT COMPONENTS** on the printed board. The coded terminals are connecting points for the switches and other controls mounted on the front panel.

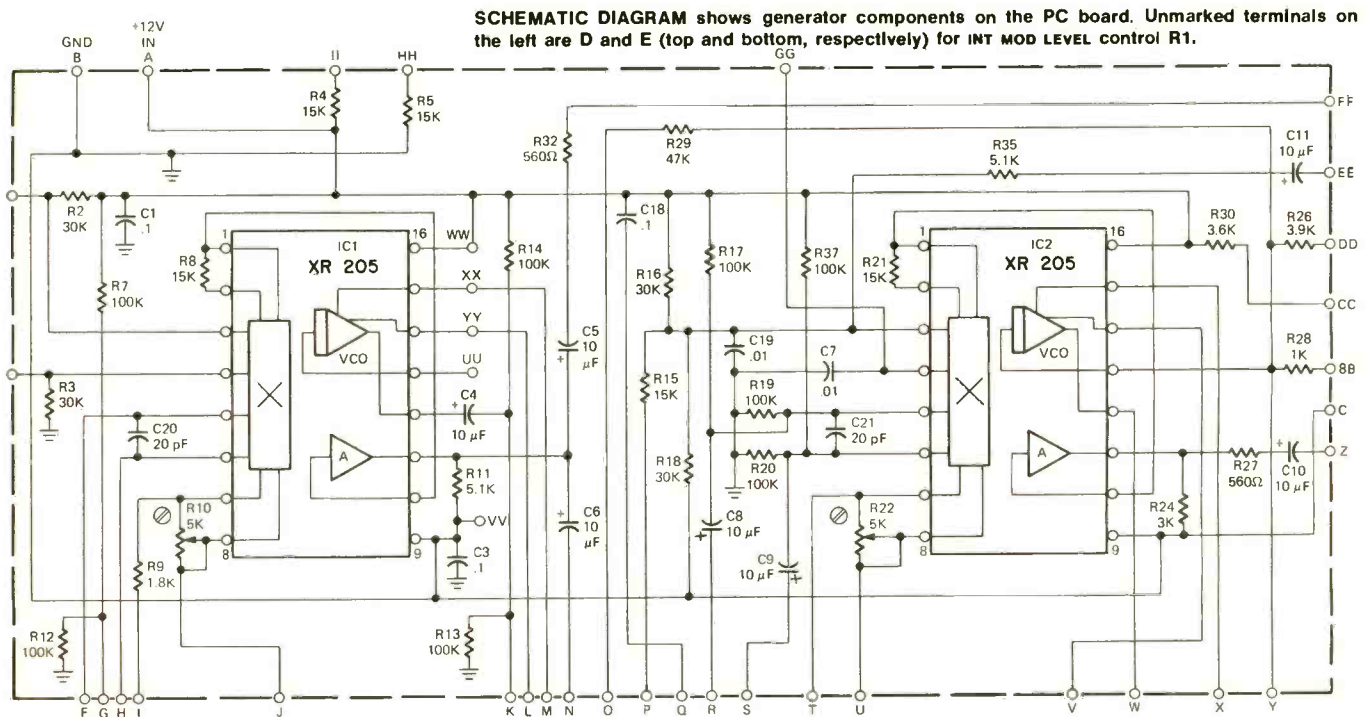

**SCHEMATIC DIAGRAM** shows generator components on the PC board. Unmarked terminals on the left are D and E (top and bottom, respectively) for INT MOD LEVEL control R1.

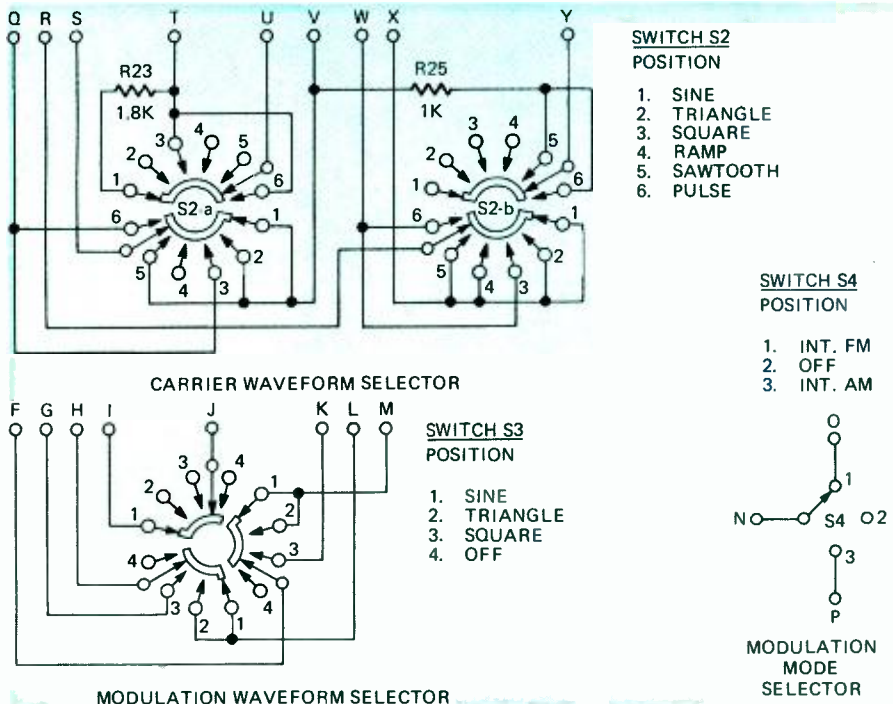

**WIRING DIAGRAM** for the CARRIER WAVEFORM and MODULATION WAVEFORM selector switches. Wire these switches and mount them on the panel before connecting to the PC board.

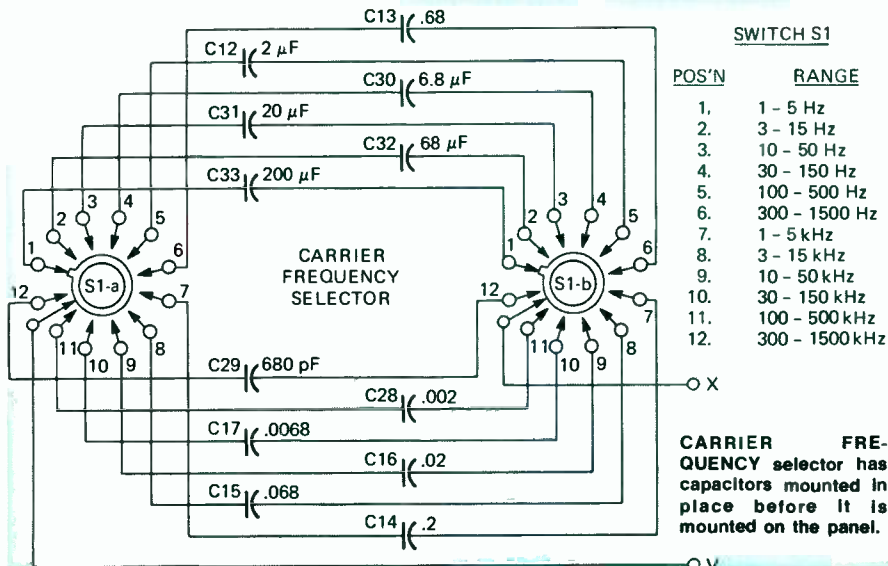

**THE CONTROL POTS** and input and output jacks are wired and connected to the circuit board as shown below. Use shielded wire for connections to the input and output jacks.

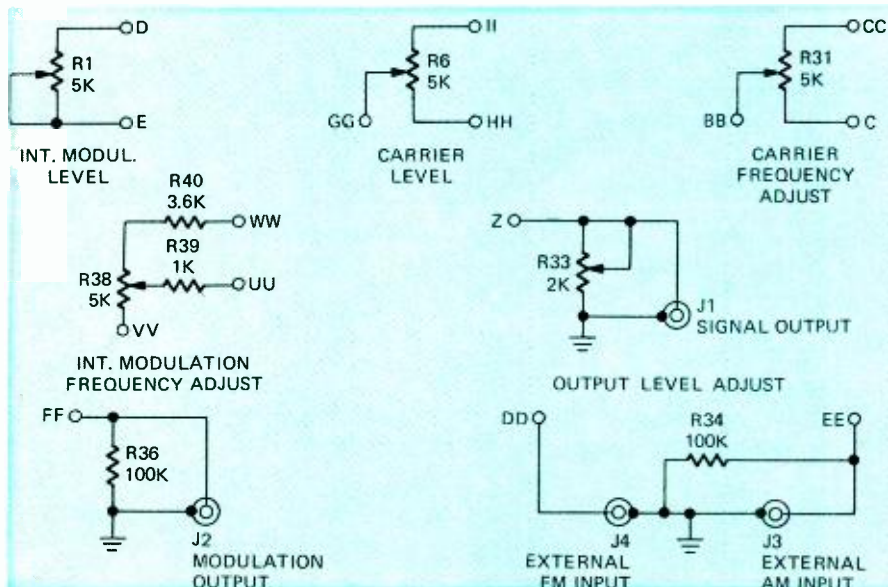

**PARTS LIST**

- All resistors are 1/4 watt unless noted**
- R1, R6, R31, R38—5000 ohms, linear taper potentiometer, 1/2w.  
 R2, R3, R16, R18—30,000 ohms  
 R4, R5, R8, R15, R21—15,000 ohms  
 R7, R12, R13, R14, R17, R19, R20, R34, R36, R37—100,000 ohms  
 R9, R23—1800 ohms  
 R10, R22—5000 ohms  
 R11, R35—5100 ohms  
 R24—3000 ohms  
 R25, R28, R39—1000 ohms  
 R26—3900 ohms  
 R27, R32—560 ohms  
 R29—47,000 ohms  
 R30, R40—3600 ohms  
 R33—2000 ohms, audio taper pot, 1/2w  
 R41—10 ohms  
 R42—4700 ohms  
 R43—6800 ohms

**All capacitors 15V or greater, unless noted**

- C1, C3, C18—0.1 μF  
 C7, C19—0.01 μF  
 C4, C5, C6, C8, C9, C10, C11—10 μF  
 C12, C22—2 μF  
 C13, C23—0.68 μF  
 C14, C24—0.2 μF  
 C15, C25—0.068 μF  
 C16, C26—0.02 μF  
 C17, C27—0.0068 μF  
 C20, C21—20 pF  
 C28—2000 pF  
 C29—680 pF  
 C30—6.8 μF  
 C31—20 μF  
 C32—68 μF  
 C35—1000 μF/25v  
 C33—200 μF  
 C34—100 pF

**Note: Timing capacitor values given are calculated values. Use nearest commercially available capacitors.**

**Use ceramic capacitors for low capacitances, mylar for the intermediate capacitances, and electrolytics for the high values.**

- S1—2-pole, 12-position non-shorting wafer (Centralab No. PA2005 or equal)  
 S2—4-pole, 6-position wafer, (Centralab No. PA2011 or equal)  
 S3—3-pole, 4-position wafer (Centralab No. PA2006 or equal)  
 S4—1-pole, 3-position (center-off) toggle  
 S5—2-pole, 6-position, non-shorting, wafer (Centralab No. PA2003 or equal)  
 S6—spst toggle

- J1, J2, J3, J4—BNC connectors, panel mount  
 IC1, IC2—XR-205 (Exar Integrated Systems)  
 IC3—723C (Fairchild)  
 D1-D4—1N4003 diode  
 T1—transformer, 117V pri; 11V(rms) sec.  
 LM1—panel lamp, 117v  
 Miscellaneous: PC Board, Case, Knobs.

**The following are available from MITS Corp., 2016 San Mateo Ave., NE, Albuquerque, N.M., 87110:**

- A complete kit of parts for building the Waveform Generator, including a case and an assembly manual, for \$89.50.**
- Two XR-205 integrated circuits only, for \$34.95.**
- Generator printed circuit board, for \$4.95.**

put above. Here again, you should use a scope or distortion analyzer and the "minimum" distortion should be about 2.5%.

Finally check the waveforms produced by various settings of the modulator and carrier waveform selector switches (S3 and S2, respectively) at their respective outputs (J2 and J1) with the modulation mode switch at position 2 (off), i.e. without any modulation of the carrier waveform. If any of the waveforms are in an order other than that shown, check the switch wiring and the leads between the switches and the board for interchanged connections.

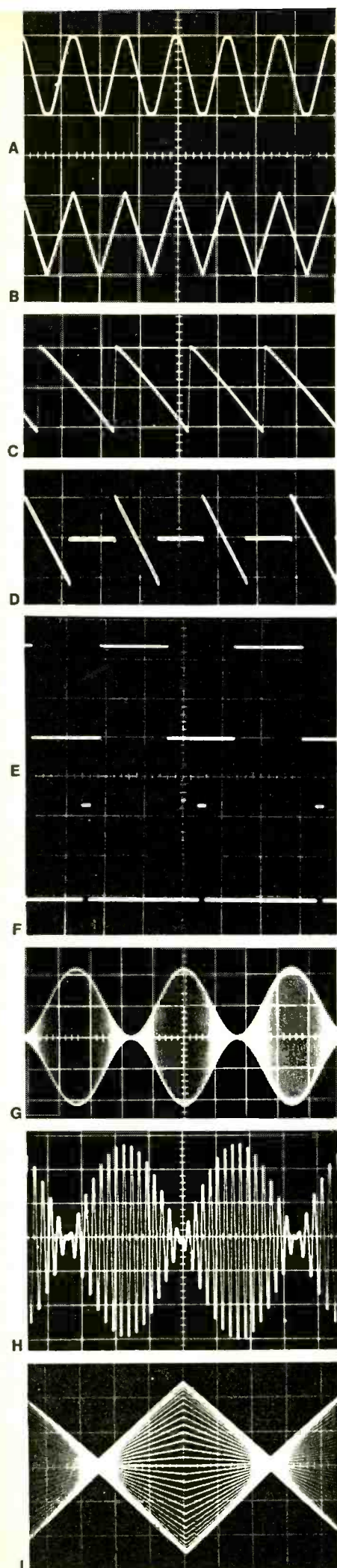

### Operation of the waveform generator

Perhaps, the best way to understand how to use the waveform generator is to go through the controls and learn what their effect is on the outputs. Then, we'll look at some examples.

**1. Carrier Frequency Range (S1)**—This switch selects the frequency range of operation for the carrier generator by selecting the timing capacitor that is inserted in the circuit of IC2. The frequency generated for a given timing capacitor can be calculated with the equation  $\text{freq} = 400/C$  where freq is in Hz and C is in  $\mu\text{F}$ . The nominal ranges for the twelve positions of S1 are:

POSITION	FREQUENCY RANGE
1	1-5 Hz
2	3-15 Hz
3	10-50 Hz
4	30-150 Hz
5	100-500 Hz
6	300-1500 Hz
7	1-5 kHz
8	3-15 kHz
9	10-50 kHz
10	30-150 kHz
11	100-500 kHz
12	300-1500 kHz (0.3-1.5 MHz)

These frequency ranges apply only to the symmetrical waveforms (sine, triangle, square, and ramp). For the asymmetric waveforms (sawtooth and pulse) the frequency is approximately 50% lower for each setting.

**2. Carrier Frequency Adjust (R31)**—This control serves as a fine frequency tuner and varies the carrier frequency over a 5:1 range for any given setting of S1. This is accomplished by varying the dc bias to pin 13 of IC-2.

**3. Carrier Waveform (S2)**—Selects the carrier waveform:

POSITION	WAVEFORM	TRACE
1	Sine	A
2	Triangle	B
3	Square	E
4	Ramp	D
5	Sawtooth	C
6	Pulse	F

**4. Carrier Level (R6)**—This control adjusts the amplitude of the carrier waveform. The carrier amplitude is minimum with R6 at its midpoint; amplitude is maximum at the two extreme settings. DC bias across

pins 3 and 4 of IC2 is varied, thereby controlling the gain characteristics of its modulator section. With this arrangement, the phase of the carrier waveform is reversed if the setting of R6 is varied from its upper to lower value.

**5. Modulator Frequency Range (S5)**—This selector switch works in a manner similar to that of the Carrier Frequency Range switch. The relationship between timing capacitor values and the resultant frequencies is the same as before. Nominal modulation ranges are:

POSITION	FREQUENCY RANGE
1	100-500 Hz
2	300-1500 Hz
3	1-5 kHz
4	3-15 kHz
5	10-50 kHz
6	30-150 kHz

**6. Modulator Frequency Adjust (R38)**—This works the same way on the modulation frequency as R31 does on the carrier frequency. It similarly provides a 5:1 frequency tuning range.

**7. Modulation Waveform (S3)**—This 4-position switch selects one of the 3 modulation waveforms or turns off the modulation signal completely. Settings are:

POSITION	WAVEFORM
1	Sine
2	Triangle
3	Square
4	Off

**8. Modulation Level (R1)**—Sets the amplitude of the modulation generator, IC1. The signal amplitude is maximum when R1 is at its maximum setting.

**9. Modulation Mode (S4)**—Used to select either Internal FM (Position 1), Internal AM (Position 3), or External Modulation (Position 2). In the external mode, both AM and FM signals can be input simultaneously to produce a variety of rather complex and unusual waveshapes. We'll look at some examples of these below. Of course, the internal modulation signal is always available at J2 for external use. Thus it is possible to connect a jumper between this jack and the AM and FM inputs for increased modulation versatility.

**10. Output Level (R33)**—This potentiometer adjusts the level of the overall output signal, whether modulated or not. Note, however, that if no amplitude modulation is employed, R33 does not have to be used to control the amplitude of the output signal. Alternatively, the signal level can be varied by adjusting R6, the carrier level potentiometer.

Unusual waveforms that you may need at some odd moment are sawtooth-modulated AM with suppressed carrier (trace J), square-wave-modulated carrier (trace K) and suppressed-carrier with ramp modulation (trace L).

### Unmodulated (CW) output

Turn off the modulation signal by setting S4 to position 2 (Off). Select the desired waveform with S2 and set S1 to the frequency range of interest, making a fine frequency adjustment with R31. Now adjust the output signal amplitude with either R6 (Carrier Level) or R33 (Output Level), or a combination of the two. Scope traces A thru F illustrate the basic waveforms obtainable.



Here are some *typical* performance data for these waveforms:

#### SINE WAVE

Max amplitude 3 V P-P  
Distortion 2.5%

#### TRIANGLE

Max amplitude 3 V P-P  
Linearity  $\pm 1\%$   
Asymmetry  $\pm 1\%$

#### SAWTOOTH

Max amplitude 3 V P-P  
Linearity 1.5%

#### RAMP

Max amplitude 1.4 V P-P  
Linearity 1%

#### SQUARE WAVE

Max amplitude 3 V P-P  
Rise time 80 ns  
Fall time 60 ns

#### PULSE

Max amplitude 3 V P-P  
Rise time 80 ns  
Fall time 60 ns

#### Variable-frequency modulation

Set the modulation mode (S4) to position 1 (FM). Select the desired carrier and modulation waveforms with S2 and S3, respectively and then select and tune the carrier and modulation frequencies with S1 and R31 (for the carrier) and S5 and R38 (for the modulator). Adjust the three level controls to obtain the wave shape of interest.

#### External FM

Set S3 (Modulation Waveform) to position 4 and S4 (Mode) to position 2, and rotate R6 (Carrier Level) to maximum. The external FM signal can now be input at J4. It should be capacitively coupled to J4 to avoid any shift in carrier frequency that might result from dc level changes.

#### Internal amplitude modulation

AM operation with either a suppressed carrier or double sideband. Let's look at each one separately.

a) *Suppressed carrier*—Initially set S4 (Modulation Mode) to position 3 (Internal AM), S3 (Modulation Waveform) to position 4 (Off) and R33 (Output Level) to maximum. Adjust the carrier level (R6) to maximum. Obtain a "null" at the output (J1). Then, select your modulation waveform and amplitude (S3 and R1, respectively). Once the initial setting has been made, use R33 to adjust your output amplitude (scope trace H).

b) *Double sideband*—Set up the waveform generator as for suppressed carrier operation, with the Modulation Amplitude (R1) at maximum. Now, increase the carrier level (R6) from "null" position, while decreasing R1, to obtain the desired modulation level. Here again, use R33 to vary the signal amplitude as in scope trace G.

**NOTE:** It is possible to obtain a crystal-stabilized AM signal by replacing one or more of the timing capacitors with a crystal. If you do this, be sure to use a trimmer capacitor (about 100 pF) in series with the crystal to tune it to its proper operating frequency. Set S1 to the position that selects the crystal you want to use, S2 (carrier waveform) to position 3, and S4 (modulation mode) to position 3. Select the modulation waveform you're interested in with S3. Set the modulation and carrier levels as

we've already described above for suppressed carrier and double sideband operation. The sweep and FM controls cannot be used with crystal-controlled signals.

#### External AM

Set S4 to position 2 and S3 to position 4. Use R6 to set the carrier level and S3 to select the carrier waveform. An external modulation signal can then be input at J3.

#### Tone burst generation

Tone bursts can be generated by using a square-wave-modulated suppressed carrier mode of operation. The waveform generator is set up for suppressed carrier operation with S4 set at position 3 (Int. AM).

When an input square wave is applied to IC2 from IC1, the carrier frequency will appear at the output as a tone burst, lasting for the duration of the input pulse. This can be selected by adjusting the modulation frequency. Additional AM can be superimposed onto the tone burst by applying a second modulation signal simultaneously with the burst signal (scope traces M and N).

#### Frequency sweep and FSK

You can sweep your waveform generator through a 5:1 frequency range by applying an external 0 to +6v dc bias to J4. Set R31 at its midpoint (scope trace O). An FSK output can be obtained by applying a keying pulse to the sweep input of IC2 (IC terminal 13) via J4 (scope trace Q).

#### Phase-shift keyed signals (PSK)

If the polarity of the bias across pins 3 and 4 of IC2 is reversed, the phase of the output signal is shifted 180°. The output signal amplitude is unaffected when the keying pulse amplitude is less than 2 volts (scope trace P).

#### Simultaneous AM/FM

The amplitude and frequency modulation inputs of the XR-205 integrated circuit can be operated independent of each other. Thus, the carrier signal generated by IC2 in your Waveform Generator can be simultaneously amplitude and frequency modulated to generate some rather complex waveforms (scope traces R, S and T). **R-E**

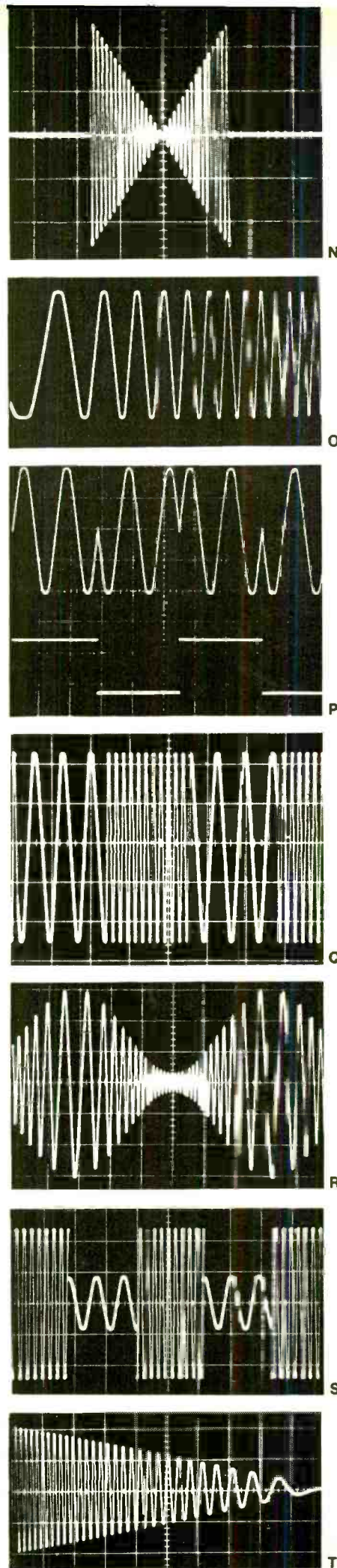
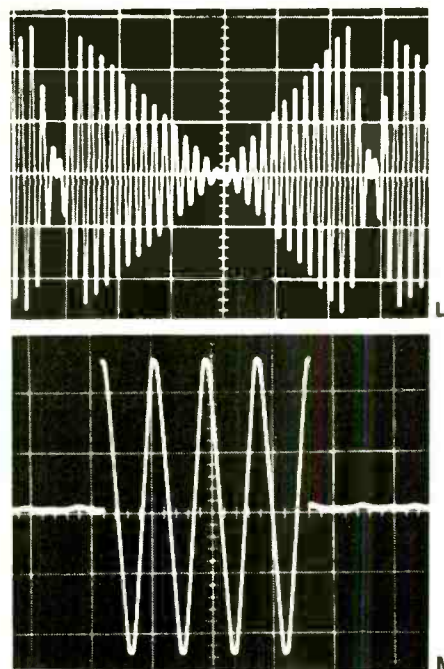

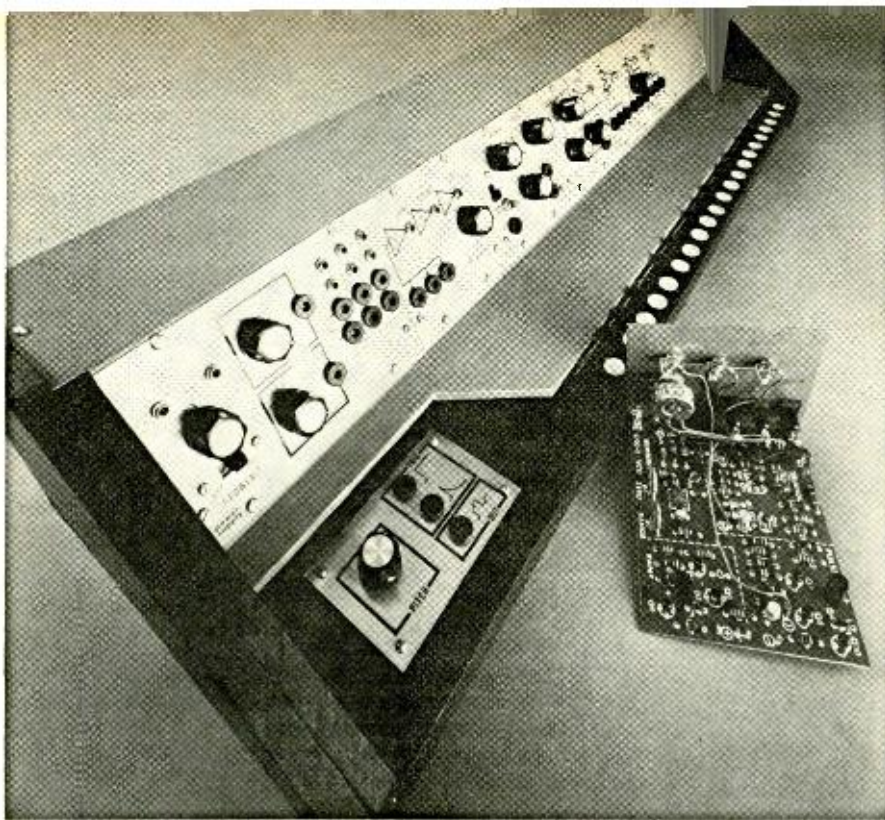

# BUILD

## A MODULAR

Part III: Complete finish the

By now you have completed the synthesizer electronics from details in the May and June issues and are now ready to finish the project. The keyboard—usually the most expensive part of a synthesizer—is simple and inexpensive. Parts for its construction are easy to find.

Form the key springs from .032 music wire (available from hobby shops) to the dimensions shown in Fig. 9-a. Exact dimensions are not critical but for the best appearance of the finished unit all the springs should be identical. You will need 36 of the springs and of this number, 15 will be further bent as shown in Fig. 9-b so they can be used for the sharp and flat keys.

The white and black buttons at the end of the key springs are just that—shirt buttons that come with a small stud on the back. The buttons are positioned on the springs so that the stud fits into the curve of the key spring and are fastened in place with clear household cement.

Fasten the key springs to a 22" x 3" piece of 1/2" plywood using two No. 4 x 3/8" wood screws and two washers on each spring as shown in Fig. 10. The holes for the two screws that hold down each spring as well as the single screws that will fasten down the voltage pick-off spring in a later step are all on 1/2" centers along the edge of the support block. Note two things in particular; the keys are arranged in groups of 5 and 7 corresponding to a piano keyboard with 1" spaces between the groups and the final key on the right hand end is fastened down by the slim strip of scrap copper-clad so that will also clamp and make contact with the resistance element.

Mount the conductive vinyl to the keyboard assembly. Secure the right hand end with a single No. 4 x 3/8" wood screw through the copper-clad strip which fastens down the right hand key spring. Secure the left hand end of the strip with a second shorter scrap of copper-clad and two wood screws. Makes sure that the copper side of

\* President, PAIA Electronics

the strips are facing down against the vinyl. Two notes; the copper-clad strips extend about 1/2" beyond the back of the key spring support block and serve as soldering points for the connections to the strip. Also, the rear edge of the vinyl strip extends beyond the rear edge of the support block and rolls under the block and is clamped when the assembly is installed in the case.

When the vinyl strip is in place, form and install the wiper contacts shown in Fig. 11. One of each of these springs goes under

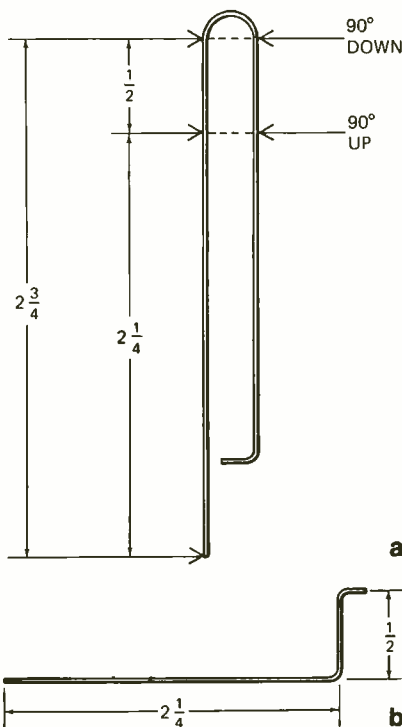

FIG. 9—THE BASIC KEY SPRING (a) is formed from music wire. Make 36. For the black keys, take 15 springs and make 90° bends 1/2 inch apart at the 2 1/2 and 2 3/4 inch points so side view is as shown at b.

the heads of the rear screws that hold down the key springs and then touches the vinyl strip.

Temporarily place the keyboard assembly in the case and mark the location of the 22" x 1" piece of copper-clad that acts as the key-down detector strip. When the exact location has been determined fasten the strip in place with seven No. 4 x 3/4" wood screws and 5/16" spacers. Place a soldering lug under the right-most screw head.

Roll the excess vinyl under the keyboard assembly and fasten the assembly in place with a single No. 4 x 3/4" wood screw through each end.

Make the final adjustments on the keysprings by bending them slightly or by loosening the screws and sliding them back and forth until they are all even and level. Bend the voltage pick-off springs slightly so that in their normal position they touch neither the key springs nor the key-down detector strip.

Build up the power bus assembly as shown in the photos using four 4-lug terminal strips and four 17" lengths of .032 music wire. Solder the music wire through the holes that cinch the lugs to the insulating support. Use four wood screws to fasten the assembly in place. For convenience, designate the upper rod of the power but

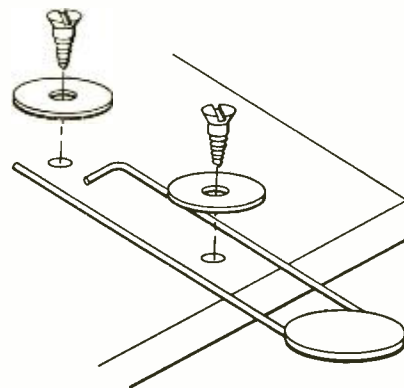

FIG. 10—TWO WASHERS AND WOOD SCREWS on 1/2-inch centers hold key springs in place.

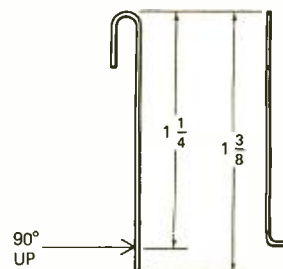

FIG. 11—WIPER CONTACT springs are formed to connect conductive strip to the keys.

# ELECTRONIC MUSIC SYNTHESIZER

*the keyboard and tune the electronics to synthesizer. Here are the details you'll need.*

by JOHN S. SIMONTON, JR.\*

“+ +”, the second rod “+”, the third ground and the fourth “-”.

Cut, drill, paint and label the control panel and install potentiometer R22 and three pin jacks. Install the control panel in a cut-out in the case using four wood screws. Use two small “L” brackets to fasten the controller circuit board to one end of the case as shown and make the connections from the various labelled circuit board points to the power bus, controls, jacks and solder lugs. Note that circuit board point E goes to the right end of the vinyl strip.

This is a convenient point to stop assembling and make the final adjustments between the VCO and the keyboard. Temporarily connect the output of the power supply and the VCO to the power supply bus. Jumper the S/H OUT to the left input jack of the VCO and the VCO pulse output to an amplifier.

Press and hold the extreme right hand white key and use the PITCH pot to zero beat the resulting tone against the second C above middle C of a tuned musical instrument (at this point it does not matter that the right hand key is actually E, this is simply a preliminary adjustment).

Connect a clip lead to the piece of copper-clad that is holding down the left end of the vinyl strip and use the other end

of the lead to clip the voltage pick-off spring and key-down detector strip together. The tone from the oscillator is now zero beat against C below middle C using trimmer resistor R21 on the controller circuit board.

Release the jumper and repeat the tuning of the right hand key with the “pitch” control. Go back and forth between these two steps until the right hand key produces the second C above middle C whenever it is pressed and the jumper from the low end of the controller produces C below middle C.

Press and hold the seventh white key of the controller (E) and use the adjustable spring wiper to zero beat this tone against middle C. Press the fourteenth white key (also E) and zero beat this note against C above middle C. With this done, the lower end of the strip, seventh white key, fourteenth white key and last white key should be at 0.625, 1.25, 2.5 and 5 volts respectively.

In the absence of a tuned pitch source roughly this same procedure can be followed using Lissajous figures to indicate a frequency of 130 Hz., 260 Hz., 520 Hz. and 1040 Hz. for the four points calibrated above. Set the reference signal source for 260 Hz and *do not change it during tuning* (since you are tuning to exact multiples of

the reference you eliminate non linearities in the frequency generator from consideration). Once the octave intervals have been set up, the notes in between can be tuned amazingly accurately by ear.

Press and hold the seventh key and using the “pitch” control zero beat this tone against the E above middle C. Complete the tuning of the remaining controller keys by simply adjusting the wiper springs so that each note is zero beat with the equivalent note on the reference instrument.

With the controller fully calibrated the decorative keyboard cover and lower module support strip may be permanently installed using No. 4  $\times$   $\frac{3}{4}$  wood screws and  $\frac{1}{4}$ ” spacers where needed. Make sure that not more than one screw passes through both the module support strip and the vinyl strip otherwise a portion of the strip will be shorted out. The upper case cover can also be installed at this time.

Connect the power supply output terminals to the power bus rods and install the module using No. 4 self-tapping sheet metal screws. In a similar manner make the power connections from the “+”, ground and “-” power bus rods to the VCO power input points and fasten this module in place. R-E

## PARTS LIST (Voltage-Controlled Oscillator) For Fig. 4, May '72

- C1—1- $\mu$ F Mylar
- C2—470-pF disc
- C3, C4, C5—2-2- $\mu$ F 6V electrolytic
- C6, C7—100- $\mu$ F 6V electrolytic
- D1, D2—1N914
- D3, D4—5.6V Zener
- IC1—748 op-amp
- Q1, Q10—2N5139
- Q2—2N4871
- Q3, Q4, Q5, Q6—2N2712
- Q7, Q8, Q9—2N5129
- All resistors  $\frac{1}{2}$ W 10%
- R1, R2, R3—150,000 ohms
- R5, R31—100,000 ohms
- R6, R29, R35—82,000 ohms
- R8—27,000 ohms
- R9, R33—47,000 ohms
- R10, R21, R24—4700 ohms
- R11—68,000 ohms
- R12, R20—5600 ohms
- R13, R28—1000 ohms
- R14, R17, R18—6800 ohms
- R15—330 ohms
- R16—47 ohms
- R22—680 ohms
- R23—3.9 megohms
- R27—470 ohms
- R30—10,000 ohms
- R32—8200 ohms
- R34—100 ohms
- R36, R37—270 ohms
- R4, R7—trimmer potentiometer, 50,000 ohms
- R19—trimmer, 100 ohms
- R26—trimmer, 1000 ohms
- R25—linear taper pot, 1000 ohms
- MISC: Circuit board, front panel, knob, hardware, (3) tip jacks, (3) miniature phone jacks, wire, solder, etc.

## KIT SUMMARY

No. 2720—Kit of all parts for duplicating the complete synthesizer. Includes all parts, panels, circuit boards and detailed instructions. \$139.00 plus postage for 18 lbs and insurance.

No. 2720-2—VCO kit including circuit board. \$24.95 ppd.

No. 2720-2pc—VCO circuit board only. \$4.00 ppd.

No. 2720-6—Complete kit of all parts for duplicating the prototype shown including case, preformed springs, front panel, circuit board electronics, vinyl strip. \$37.00 plus postage for 12 lbs. and insurance.

No. 2720-6pc—Circuit board only. \$3.50 ppd.

No. 2720-6v—Pre-cut conductive vinyl strip. \$2.50 ppd.

No. 2720-6pc—Sample/Hold circuit board. \$3.50 ppd.

No. 2720-7—Power Supply kit. \$22.00 + 2 lbs. postage.

No. 2720-7pc—Power Supply circuit board. \$4.00 ppd.

A controller kit featuring a professional 3 octave organ keyboard is also available. Details available on request.

The items listed above are available from, PAIA Electronics, Inc., P. O. Box 14359, Okla. City, OK 73114.

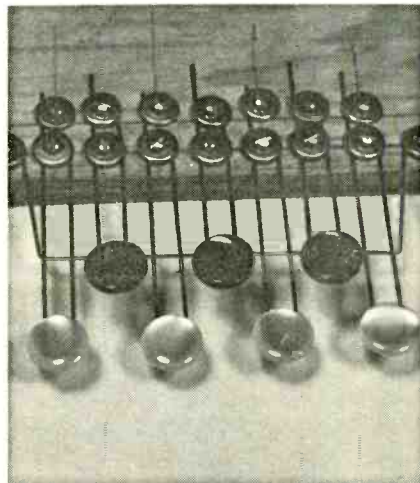

KEYBOARD CONSTRUCTION is shown in photo above. Photograph below shows synthesizer chassis with just the keyboard in place.

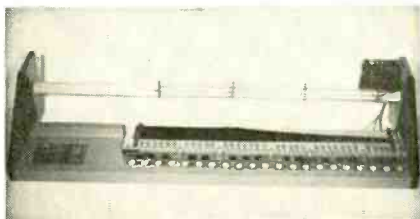

# SPEED TROUBLESHOOTING

The ultimate approach to troubleshooting technique described in a four-part series that three-part final exam and see if you are the hot-

by JONATHAN L. TURINO

THIS IS THE CONCLUDING ARTICLE OF our four-part series on logical troubleshooting technique, and the troubleshooting test it includes is designed around the cut-it-in-half method that was described in the earlier articles. The test is not an easy one, but if you use a logical approach and all of the information given, you should be able to find each defective component in the number of steps allotted.

The answers to last month's quiz along with a short note on the reasoning that should have allowed you to pinpoint the defective stage in two steps and the answers to this month's test appear at the end of this article.

Before beginning the test, let's recap some of the previously developed ideas necessary for logical troubleshooting.

The most important item necessary for logical and effective troubleshooting (besides test equipment) is a block diagram. (The schematics in Fig. 1, Fig. 2, and Fig. 3 are broken up into functioning blocks, with arrows between blocks to show the signal flow from input to output.) Finding one defective component among the many in each device is next to impossible. Finding a defective component among the handful in the nonoperating stage of each device is child's play (almost). The block diagram makes each function of the unit like a component in a single stage and the fault isolation, done logically, is simple.

As far as the actual troubleshooting steps are concerned, they might be listed like this:

1. Check the simple things first.

2. Glean all the information that is available from controls and indications.

3. Make a rough guess about where the trouble is and verify that the input to and output from that section confirm your diagnosis.

4. Abandon your guess from Step 3 if your first checks do not help to prove you are right and make another (educated) guess using the additional information about what *isn't* wrong.

## TROUBLESHOOTING TEST

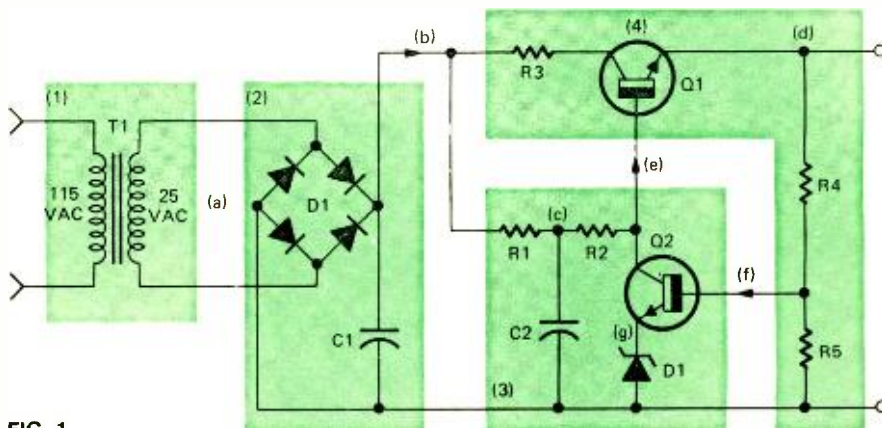

FIG. 1

### Part 1

**Symptom:** With 117 Vac applied, the output voltage from the regulator is 0 Vdc. A visual inspection indicates that no components are charred or burned.

Use the block diagram to pick your first measurement point. The resulting measurement is +33 Vdc. Point \_\_\_\_\_.

Your next measurement should be at point \_\_\_\_\_. The voltage reading at your second measurement is 0 Vdc.

Defective block \_\_\_\_\_.

Using the schematic now, take your next measurement at point \_\_\_\_\_. The reading is 0 Vdc.

Which component is most probably defective? \_\_\_\_\_

### Part 2

V1 - 28V

V2 - 0V

V3 - 0V

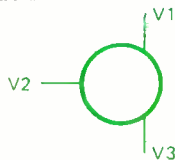

**Symptom:** With a 0.1 V p-p sinewave input to the preamplifier in Fig. 2, the output signal as shown on the oscilloscope is missing altogether.

The result of your first measurement, which should be at point \_\_\_\_\_, is "no output".

The result of your next measurement, which should be at point \_\_\_\_\_, is "signal present".

The defective stage is stage \_\_\_\_\_.

Voltage readings taken in the defective stage (illustrated by the transistor below) are as follows:

The defective component is most probably \_\_\_\_\_.

### Part 3

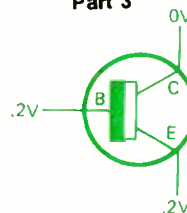

**Symptom:** There is no signal present at either output of the FM multiplex decoder in Fig. 3.

The first thing you should verify is that the correct \_\_\_\_\_ is present.

The next thing you should do is to verify that the \_\_\_\_\_ is present.

Assuming that both of your above steps confirm that the multiplexer itself is actually defective, where would you check for a signal first? Point \_\_\_\_\_.

The result of this first signal check is "no signal". Your next check should be at point \_\_\_\_\_.

The result of this check is "signal present". The defective stage is stage \_\_\_\_\_.

Voltage readings in the defective stage are shown on transistor above.

Defective part \_\_\_\_\_.

# With A Logical Approach

is the author's "cut-it-in-half" tech- began in April. Are you ready to take the shot troubleshooter you think you are?

5. Use cut-it-in-half troubleshooting wherever possible to find the defective stage of a section in the shortest possible time.

6. Use logic, reason (and caution) to find the defective component in the non-operating stage.

7. Make the actual repair and verify that the equipment operates properly.

8. If you still have the same trouble (unlikely) or more different troubles, go back to Step 1 and start over!

Step 8 is, of course, the last step in many procedures, whether you are designing or troubleshooting something. If anything can go wrong, it will, and it is up to you to outsmart the elusive electron. Remember that

until you are down to the component level you are usually looking for rather gross signal indications—the signal is either there or it is not—so that you do not get bogged down in the individual components until you have localized the problem.

You should be an expert by now, and ready to tackle the three troubleshooting problems we have devised to test your skill. Use any pieces of test equipment you desire during the troubleshooting process, and keep in mind that the measurement results we have provided make it imperative that you troubleshoot in accordance with the concepts presented in this series and recapped in Steps 1 through 8 above. Good luck.

## ANSWERS

Part 1: b, e, 3, c, C2 (shorted)

The first measurement yielded +33 volts and point b is the place to find it. (continued on page 91)

FIG. 2 (left)—FOUR-STAGE PREAMPLIFIER used in Part 2 of your test. You can use it for audio and video circuits. FIG. 3 (below)—FM MULTIPLEX DECODER circuit is the example used in Part 3 of the test.

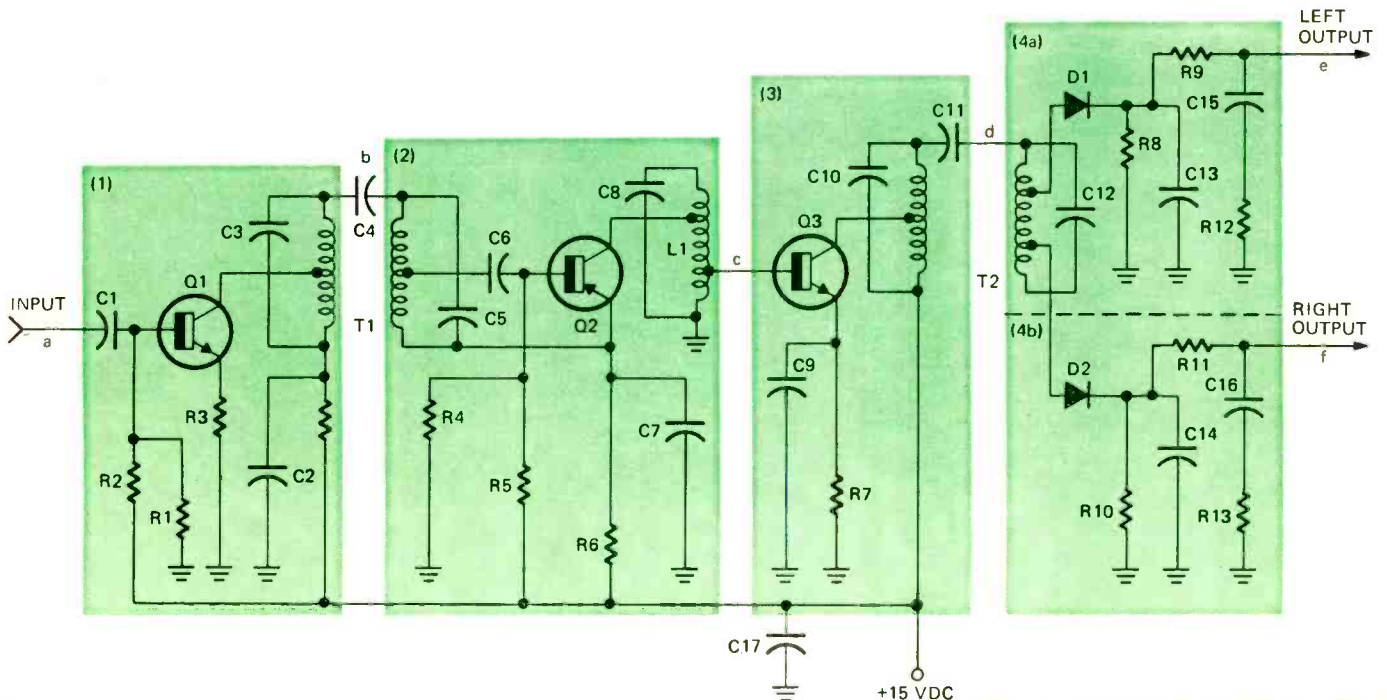
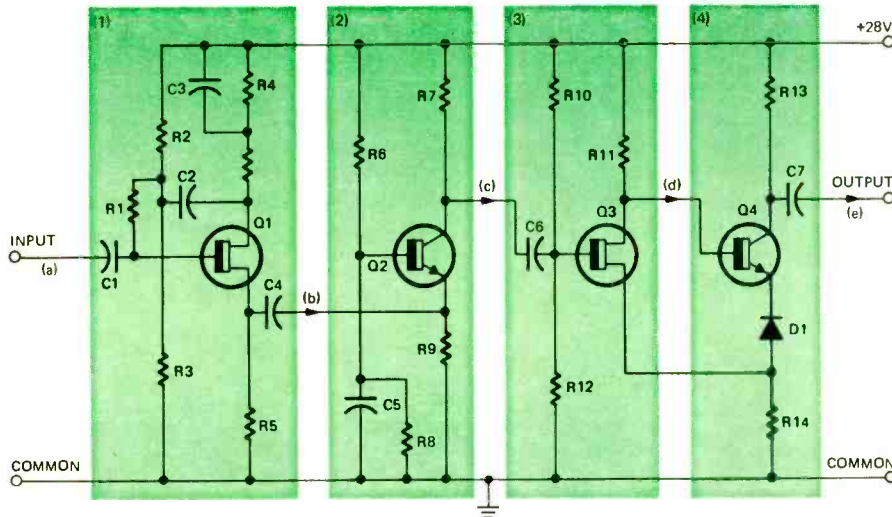

# STEP-BY-STEP TV TROUBLE-SHOOTER'S GUIDE

THE NEWER SOLID-STATE VERTICAL sweep circuits can be rough to handle, especially if they're dc coupled all the way; with the principal problem being *where to start* if there is **NO** vertical deflection.

Where there IS deflection, transistor circuits are subject to the same types of problems as vacuum tubes. These include insufficient sweep, poor sync lock, bad linearity, foldover, jitter, excess sweep, scan-line pairing and raster failure to roll up or roll down at extreme vertical hold control settings.

Any of these problems can be caused by bad tubes or transistors and very simple circuits are easily investigated initially by out-of-circuit tube checks and in-circuit transistor checks—except outputs; and this also presupposes all semiconductors are soldered in. Some aren't. Dc voltages, of course, are next, and all sources from power supplies must be within  $\pm 10\%$ —some even closer—for such stages to work. Now if voltages and active circuit components are all right, you must then consider the other problems we'll outline briefly: Insufficient sweep means insufficient bias for grids and cathodes and bases and emitters. Excess sweep is a simple case of overbias such as a leaky coupling capacitor between stages. Jitter can come from poor connections, a worn (current path) or dirty vertical control (often centering), and horizontal voltage feedback through the vertical deflection coils. Foldover means the vertical output is driven into partial saturation. Poor sync lock comes from bad R-C oscillator time constants, as does raster center lock (or lack of it). Line-pairing is often due to problems in the sync separator unless station transmission is in trouble. Those are the generalities—now for the specifics.

## Signal injection

The schematic shows a four-transistor deflection circuit with vertical output transformer. (VOT), sync input, and the various controls. Below the schematic is a simple block diagram of the sweep circuit functions with the

same controls. We'll get to the detailed theory of operation later; but right now, let's try and get the pesky thing going, then concentrate on how it works, just in case this is a real toughie.

Either you have partial vertical deflection or you have none. And the easiest way to handle this problem immediately is by signal injection. But be very, very careful of impedances and polarities. The output of Q2 is a negative voltage to turn OFF Q3 that has been supplying drive for Q4. Therefore, you will need a negative-going pulse voltage at the low end of R11, or the base of Q2, but a rising sawtooth at the base of Q4 to do the trick. A low-impedance source with a net of some 6 volts that includes cir-

cuit drops will produce at least an instantaneous vertical deflection visible on the pix tube *if* couplers, transformers, and other components beyond these points aren't open or shorted. Even a wire from the collector of the sync separator through a  $0.22 \mu\text{F}$  capacitor can produce a momentary deflection through R11 if the oscillator is defective. For instance, Q3, Q4, and the VOT and deflection yoke are OK if a pulse fires all of them from the emitter of Q2. If not, try the base of Q3, then its emitter, etc., until either something or nothing works. Test equipment useful here would be a function generator, B & K Television Analyst, a pulse generator, or any positive ramp or negative spike source as long as the repetition rate is

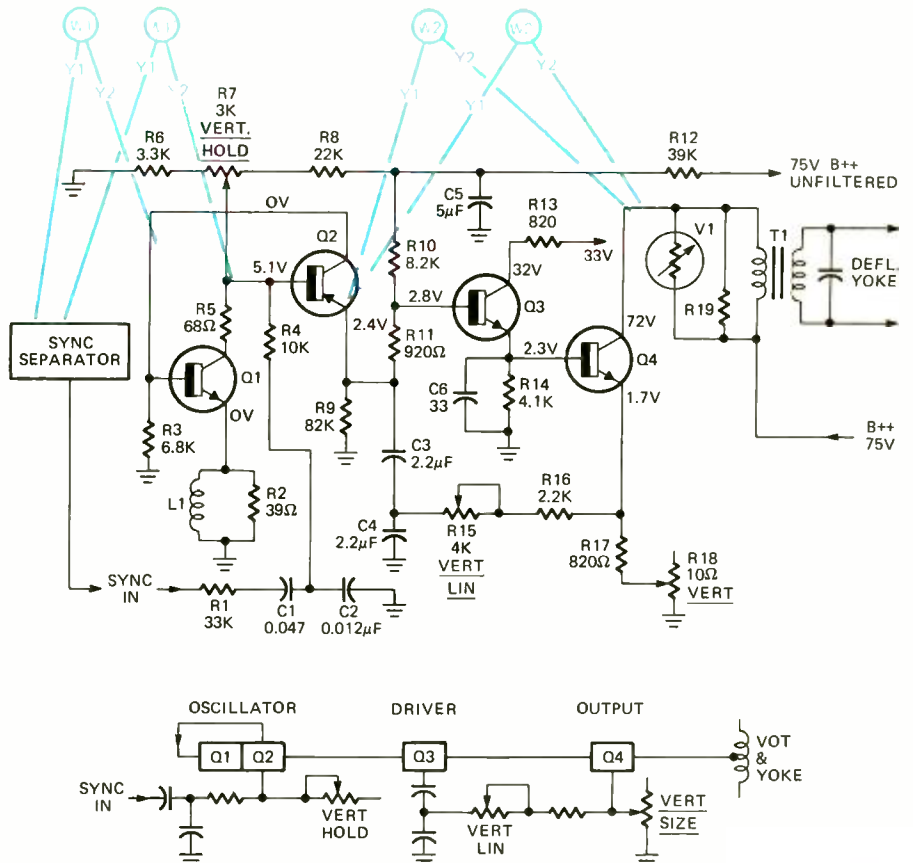

**SCHEMATIC OF TRANSISTOR VERTICAL DEFLECTION CIRCUIT with block diagram below. Waveforms W1 and W2 are produced with dual-trace triggered-sweep scope and show correct operation.**

*Defects in a solid-state vertical sweep oscillator and output circuit can be tough to isolate. Here is how to attack the problem and keep it from getting the best of you.*

by STAN PRENTISS

approximately 60 Hz. But they must be ac coupled only to prevent further circuit damage.

**Trouble chart and waveforms**

The *troubleshooting chart* now can take over and will lead logically to the various steps following signal injection with or without vertical deflection. The "look and feel" suggestions are entirely serious since transistors are current-operated devices and shorts—even at low voltages—do make electrons and holes come running, kicking up a lot of heat. Dc checking can be done either with a digital or analog voltmeter—depending on how much accuracy you may want or need—or a dc oscilloscope (as used to obtain the accompanying waveforms) whose accuracy is better than 3%. Use the scope for simultaneous recording of ac peak-to-peak and dc levels so that a single time-base and vertical-deflection setting will usually get you through most

sync, video, vertical, or horizontal circuits with the exception of the power outputs. Set the dc reference and there's no calculating thereafter, just a visual glance. Dc can be estimated, but also read accurately by simply flipping the DC-AC switch, and the number of divisions the waveform rises or falls negatively or positively is your dc voltage. Time base is easily determined for frequency counts since, here, each vertical division represents 2 milliseconds. So since you have  $2 \times 10^{-3} \times 8.3$  divisions for each cycle, frequency  $F = 1/T = 1/16.6 \times 10^{-3} = 60$  Hz. Ac recurrent scopes don't have either time base or dc amplifiers, but they can measure peak-to-peak values with relative accuracy, depending on calibration and vertical amplifier linearity. At low rep rates, however, an internal ac input capacitor can cause waveform distortion. Dual trace? Sure its handy for circuit-to-circuit reference, time base comparison, dc levels,

and waveform analysis on a single receiver or two similar receivers with a common ground.

**Signal analysis**

Suppose this particular vertical circuit actually turned into a real bow-wow, and you aren't confident that even your trusty incircuit transistor checker is telling all the truth? Then, let's use signal analysis. Waveforms W1 and W2 are examples of satisfactory circuit operation—with Y1 (W1) taken on the collector of the sync separator at a dc response of 20 volts; Y2(W1) at the base-collector of Q1-Q2; Y1(W2) at the emitter of Q2; and Y2(W2) at the collector of Q4, the vertical output.

Now look what happens when the base and emitter of Q1 are shorted together. Y1'(W2') doesn't continue to swing from almost dc to 4 volts, but now only 4 to 5 volts and drops its p-p amplitude down to hardly more

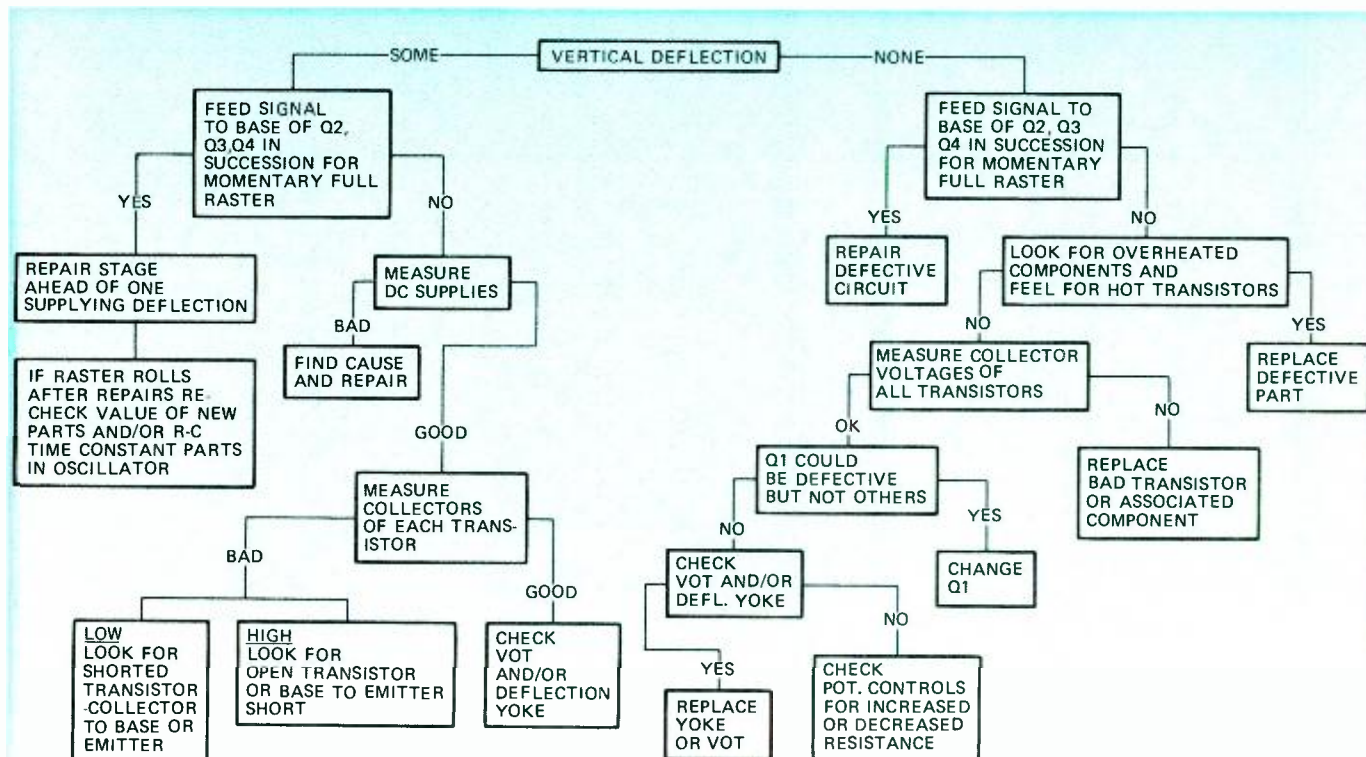

**TROUBLESHOOTING CHART** for locating malfunctions in a solid-state vertical deflection circuit. The symptom is partial deflection or no deflection at all. The first steps are the same.

than 1 volt. The Y2'(W2') trace also increases its dc operating level by some 40 volts and its amplitude drops from 300 volts to not more than 100 volts. In W1' the sync separator level and amplitude remains the same because it's R-C isolated from the vertical oscillator by R1 and C1. The Y2'(W1') waveform—taken at the base of Q2—is inverted, has little amplitude, but still obviously shows that the oscillator is trying to work, even under a handicap.

So how do you tell the problem's source? If the output transistor was this loaded by transformer or yoke defects, you'd see smoke aplenty. Also Y2'(W2') wouldn't have lost as much amplitude or changed its dc level if the oscillator had been running normally. And, finally, the worst symptom of them all is at the shorted base-emitter of Q1, where there's little or nothing—and this is why we switched to the base of Q2 for Y2'(W1'). And the oscillator, of course, is the problem.

#### How the circuit works

Since Q1 and Q2 are complementary transistors in a collector-to-base feedback loop, positive signals into the base of Q1 are inverted and drive Q2 (already biased on by R7) so that Q2 inverts this negative pulse to a positive one, but also transmits the negative pulse through its emitter. The negative pulse forces discharge of the two 2.2- $\mu$ F capacitors as well as turning off driver Q3. After the (blanking) pulse passes, C3 and C4 again begin to charge, turning on Q3 so that it once more drives the vertical output into conduction.

Dc current for Q4 is channeled through R18, while the voltage developed across it and R17 supply R15 (VERT LIN control) through R16. The linearity control then delivers feedback from Q4 that shapes the charging curve of the two large capacitors so that their output, and the subsequent outputs of Q3 and Q4 are linear. C6 in the emitter of Q3 is a small filter, while V1 is a voltage-sensitive resistor that decreases resistance with extraordinary voltage spikes and so shunts R19 and protects transistor Q4. R9, R10, R11 are simply voltage dividers to establish bias potentials for Q2 and Q3.

Cutoff pulses from the Q1-Q2 oscillator occur about every 15.26 milliseconds and last for a short interval so that Q3 and Q4 are blanked for about 1.4 milliseconds during the retrace time of each field (two fields make a frame and there are 30 frames per sec). Consequently, total trace and retrace for a single field at the vertical repetition rate of 60 Hz for monochrome and 59.94 Hz for color is ap-

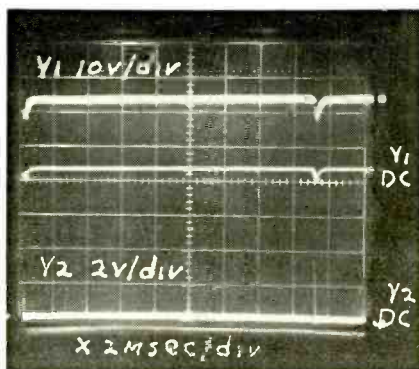

W1 WAVEFORMS Y1 and Y2 are correct for sync separator and vert oscillator, respectively.

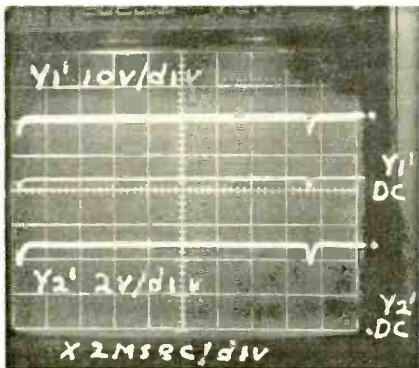

W1' WAVEFORMS. Y1' and Y2' traces develop when Q1's base and emitter are shorted.

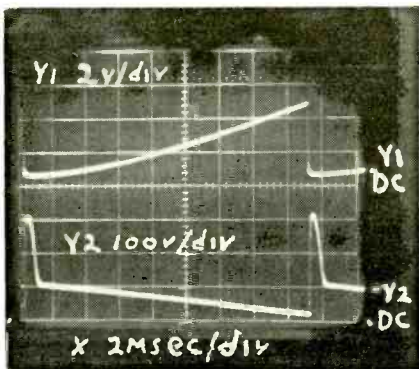

W2 WAVEFORMS with traces Y1 and Y2 normal for Q2 emitter and Q4 collector, respectively.

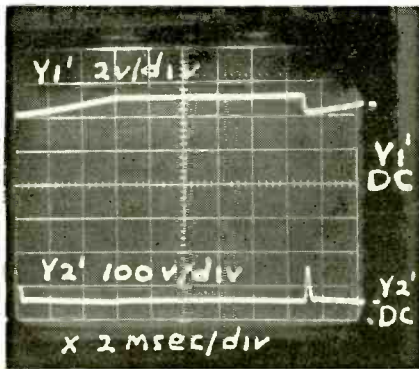

W2' WAVEFORMS show how circuit conditions change when Q1 shorts base to emitter.

proximately 16.667 milliseconds (color), close enough to calibrate the low end of your oscilloscope's time base if there's a handy pot., or if you're so inclined.

That's about the story of this ver-

tical circuit. The old vacuum-tube types had feedback from the vertical output to the input of the oscillator, plus an extensive integrator network in place of R1 and C1. Often you could get to individual parts in older receivers, but on PC (printed circuit) boards and, especially, plug-in modules, you don't want to make substitutions unless they're permanent replacements. Therefore, signal substitution and oscilloscope tracing are preferred fault finding methods wherever possible; and this is particularly true where you must also contend with integrated circuits.

Your only additional problems might be those of vertical output transformers and deflection yokes. Resistance readings *may* find a bad transformer, but decidedly not a deflection yoke. It may be necessary to "ring" both inductances using a squarewave generator and look at the result with an oscilloscope—or simply substitute the parts. Remember, however, a deflection yoke is seldom open, and a VOT is almost never shorted. Should there be a yoke short, you'll spot the trapezoidal horizontal pattern immediately.

R-E

## R-E's substitution guide for replacement transistors

### PART V

compiled by ROBERT & ELIZABETH SCOTT

R-E's Transistor Substitution Guide is a compilation of material abstracted from the substitution guides of eight leading semiconductor manufacturers and distributors. These are:

**ARCH**—Indicates the Archer brand of semiconductors sold only by Radio Shack and Allied Radio stores. Allied Radio Shack, 2725 W. 7th St., Ft. Worth, Texas 76107

**G-E**—General Electric Co., Tube Product Div., Owensboro, Ky. 42301

**ICC**—International Components, Div. of IESC, 10 Daniel Street, Farmingdale, N.Y. 11735

**IR**—International Rectifier, Semiconductor Div., 233 Kansas St., El Segundo, Calif. 90245

**MAL**—Mallory Distributor Products Co., 101 S. Parker, Indianapolis, Ind. 46201

**MOT**—Motorola Semiconductors, Box 2963, Phoenix, Ariz. 85036

**RCA**—RCA Electronic Components, Harrison, N.J. 07029

**SPR**—Sprague Products Co., 65 Marshall St., North Adams, Mass. 01247

**SYL**—Sylvania Electric Corp., 100 1st Ave., Waltham, Mass. 02154

Radio-Electronics has done its utmost to insure that the listings in this directory are as accurate and reliable as possible; however, no responsibility is assumed by Radio-Electronics for its use. We have used the latest manufacturers material available to us and have asked each manufacturer covered in the listing to check its accuracy. Where we have been supplied with corrections, we have updated the listing to include them. The first part of this Guide appeared in March 1973.





ARCH GE ICC IR MAL MOT RCA SPR SYL

2N1085	NA	NA	IRTR-76	PTC 110	HEP-243	NA	RT-154	NA	NA	GE-52	ICC-2	IRTR-89	PTC 109	HEP-2	SK 3003	RT-121	ECG 160
2N1086	RS276-2002	ICC-641	TR-08	PTC 108	HEP-641	SK 3011	RT-119	ECG 101	NA	GE-3	ICC-230/232	TR-01	PTC 138	HEP-230/232	SK 3009	RT-124	ECG 104
2N1087	RS276-2002	ICC-641	TR-08	PTC 108	HEP-641	SK 3011	RT-119	ECG 101	ECG 101	GE-3	ICC-230/232	TR-01	PTC 138	HEP-230/232	SK 3009	RT-124	ECG 104
2N1090	RS276-2002	ICC-641	TR-08	PTC 108	HEP-641	SK 3011	RT-119	ECG 101	ECG 101	GE-61	ICC-53	TR-21	PTC 132	HEP-53	SK 3124	RT-100	ECG 123
2N1091	RS276-2002	ICC-641	TR-08	PTC 108	HEP-641	SK 3011	RT-119	ECG 101	ECG 101	GE-61	ICC-53	TR-21	PTC 132	HEP-53	SK 3124	RT-100	ECG 123
2N1092	RS276-2018	ICC-243	IRTR-87	PTC 125	HEP-243	SK 3024	RT-114	ECG 128	NA	GE-61	ICC-53	TR-21	PTC 132	HEP-53	SK 3124	RT-100	ECG 123
2N1093	RS276-2004	ICC-254	IRTR-89	PTC 109	HEP-2	NA	RT-121	ECG 160	ECG 160	GE-53	ICC-53	TR-21	PTC 132	HEP-53	SK 3124	RT-100	ECG 123
2N1094	RS276-2004	ICC-2	IRTR-89	PTC 109	HEP-2	NA	RT-122	ECG 160	ECG 160	GE-1	ICC-53	TR-21	PTC 121	HEP-53	SK 3124	RT-108	NA
2N1095	NA	ICC-233	IRTR-83	PTC 121	HEP-S3020	SK 3010	RT-122	ECG 103	ECG 103	GE-18	NA	IRTR-87	PTC 125	HEP-S007	NA	RT-108	NA
2N1096	NA	ICC-641	IRTR-87	PTC 101	HEP-713	SK 3010	RT-122	ECG 103	ECG 103	GE-18	NA	IRTR-87	PTC 125	HEP-S007	NA	RT-108	NA
2N1097	RS276-2005	ICC-254	IRTR-85	PTC 102	HEP-254	SK 3003	RT-120	ECG 102	ECG 102	GE-18	NA	IRTR-87	PTC 125	HEP-712	NA	RT-108	NA
2N1098	RS276-2005	ICC-254	IRTR-85	PTC 102	HEP-254	SK 3003	RT-120	ECG 102	ECG 102	GE-4	NA	IRTR-88	PTC 106	HEP-712	NA	RT-108	NA
2N1099	NA	ICC-639	TR-03	PTC 106	HEP-233	SK 3012	RT-147	ECG 105	ECG 105	GE-3	NA	TR-17	PTC 107	HEP-2	NA	RT-124	ECG 160
2N1100	NA	ICC-233	TR-03	PTC 106	HEP-233	SK 3012	RT-147	ECG 105	ECG 105	NA	ICC-232	TR-01	PTC 105	HEP-232	SK 3009	RT-127	ECG 121
2N1101	RS276-2001	ICC-641	TR-08	PTC 134	HEP-641	SK 3010	RT-122	ECG 103A	ECG 103A	NA	ICC-232	TR-01	PTC 105	HEP-232	SK 3009	RT-127	ECG 121
2N1102	RS276-2001	ICC-641	TR-08	PTC 134	HEP-641	SK 3010	RT-122	ECG 103A	ECG 103A	NA	ICC-232	TR-01	PTC 105	HEP-232	SK 3009	RT-127	ECG 121
2N1103	RS276-2009	ICC-53	TR-21	PTC 136	HEP-53	SK 3124	RT-102	ECG 123A	ECG 123A	NA	ICC-G6001	TR-01B	PTC 105	HEP-G6001	NA	RT-124	ECG 104
2N1104	RS276-2009	ICC-53	TR-21	PTC 132	HEP-53	SK 3124	RT-100	ECG 123	ECG 123	NA	NA	TR-01B	PTC 105	HEP-G6001	NA	RT-124	ECG 104
2N1105	NA	NA	NA	NA	HEP-S3020	NA	NA	NA	NA	NA	NA	TR-01B	PTC 105	HEP-G6001	NA	RT-124	ECG 104
2N1106	NA	NA	NA	NA	HEP-713	NA	NA	NA	NA	NA	NA	TR-01	PTC 105	HEP-236	SK 3009	RT-124	ECG 104
2N1107	RS276-2003	ICC-639	IRTR-89	PTC 107	HEP-639	SK 3005	RT-118	ECG 126	ECG 126	GE-3	NA	TR-01B	PTC 105	HEP-G6001	SK 3009	RT-124	ECG 104
2N1108	RS276-2003	ICC-639	IRTR-89	PTC 107	HEP-639	SK 3005	RT-118	ECG 126	ECG 126	GE-25	NA	TR-01	PTC 105	HEP-236	SK 3009	RT-124	ECG 104
2N1109	RS276-2003	ICC-639	IRTR-89	PTC 107	HEP-639	SK 3007	RT-118	ECG 126	ECG 126	GE-16	ICC-232	TR-01	PTC 105	HEP-232	SK 3009	RT-127	ECG 121
2N1110	RS276-2003	ICC-639	IRTR-89	PTC 107	HEP-639	SK 3005	RT-118	ECG 126	ECG 126	GE-5	NA	TR-08	PTC 108	HEP-232	NA	RT-122	ECG 103
2N1111	RS276-2003	ICC-639	IRTR-89	PTC 107	HEP-639	SK 3007	RT-118	ECG 126	ECG 126	GE-5	NA	TR-08	PTC 108	HEP-232	NA	RT-122	ECG 103
2N1112	NA	ICC-641	TR-08	PTC 108	HEP-641	SK 3011	RT-119	ECG 101	ECG 101	GE-1	ICC-253	IRTR-85	PTC 102	HEP-253	SK 3005	RT-118	ECG 100
2N1113	RS276-2002	ICC-2	TR-08	PTC 108	HEP-641	SK 3011	RT-119	ECG 101	ECG 101	GE-3	ICC-254	TR-01	PTC 105	HEP-253	SK 3006	NA	ECG 160
2N1114	RS276-2005	ICC-53	IRTR-85	PTC 109	HEP-2	SK 3005	RT-118	ECG 126	ECG 126	GE-9	ICC-638	IRTR-89	PTC 107	HEP-638	SK 3006	NA	ECG 160
2N1115	RS276-2005	ICC-53	IRTR-85	PTC 109	HEP-2	SK 3009	RT-127	ECG 121	ECG 121	NA	ICC-254	IRTR-85	PTC 102	HEP-254	SK 3006	NA	ECG 160
2N1116	RS276-2009	ICC-63	TR-21	PTC 144	HEP-53	SK 3122	RT-102	ECG 123A	ECG 123A	GE-9	ICC-638	IRTR-89	PTC 107	HEP-638	SK 3006	NA	ECG 160
2N1117	RS276-2009	ICC-63	TR-21	PTC 144	HEP-53	SK 3122	RT-102	ECG 123A	ECG 123A	GE-9	ICC-638	IRTR-89	PTC 107	HEP-638	SK 3006	NA	ECG 160
2N1118	RS276-2021	ICC-51	TR-19	PTC 131	HEP-51	SK 3114	RT-115	ECG 159	ECG 159	GE-53	ICC-253	IRTR-85	PTC 102	HEP-253	SK 3005	RT-118	ECG 100
2N1119	RS276-2021	ICC-51	TR-19	PTC 131	HEP-51	SK 3114	RT-115	ECG 159	ECG 159	GE-9	ICC-638	IRTR-89	PTC 107	HEP-638	SK 3006	NA	ECG 160
2N1120	RS276-2006	NA	TR-01	PTC 105	HEP-232	SK 3009	RT-127	ECG 121	ECG 121	NA	ICC-638	IRTR-89	PTC 107	HEP-638	SK 3006	NA	ECG 160
2N1121	RS276-2001	ICC-641	TR-08	PTC 108	HEP-641	SK 3011	RT-119	ECG 101	ECG 101	GE-1	ICC-254	IRTR-85	PTC 102	HEP-254	SK 3004	RT-120	ECG 102
2N1122	RS276-2003	ICC-3	IRTR-89	PTC 107	HEP-3	SK 3005	RT-118	ECG 160	ECG 160	GE-9	ICC-638	IRTR-89	PTC 107	HEP-638	SK 3006	NA	ECG 160
2N1123	NA	NA	IRTR-85	PTC 135	HEP-254	NA	RT-121	ECG 102A	ECG 102A	GE-16	ICC-232	TR-01	PTC 105	HEP-232	SK 3014	RT-127	ECG 121
2N1124	RS276-2005	ICC-254	IRTR-85	PTC 135	HEP-254	SK 3004	RT-120	ECG 102	ECG 102	NA	ICC-238	TR-01	PTC 105	HEP-238	SK 3009	RT-127	ECG 121
2N1125	RS276-2005	ICC-254	IRTR-85	PTC 135	HEP-254	SK 3004	RT-120	ECG 102	ECG 102	NA	ICC-238	TR-01	PTC 105	HEP-238	SK 3009	RT-127	ECG 121
2N1126	NA	NA	IRTR-85	PTC 102	HEP-238	SK 3004	RT-120	ECG 102	ECG 102	GE-1	ICC-254	IRTR-85	PTC 102	HEP-254	SK 3005	RT-118	ECG 100
2N1127	NA	NA	IRTR-85	PTC 102	HEP-238	SK 3004	RT-120	ECG 102	ECG 102	GE-1	ICC-253	IRTR-85	PTC 102	HEP-253	SK 3005	RT-118	ECG 100
2N1128	RS276-2005	ICC-254	IRTR-85	PTC 102	HEP-254	SK 3004	RT-120	ECG 102	ECG 102	GE-1	ICC-254	IRTR-85	PTC 102	HEP-254	SK 3005	RT-118	ECG 100
2N1129	RS276-2005	ICC-254	IRTR-85	PTC 102	HEP-254	SK 3004	RT-120	ECG 102	ECG 102	GE-1	ICC-254	IRTR-85	PTC 102	HEP-254	SK 3005	RT-118	ECG 100
2N1130	RS276-2005	ICC-254	IRTR-85	PTC 102	HEP-254	SK 3004	RT-120	ECG 102	ECG 102	GE-53	ICC-254	IRTR-85	PTC 102	HEP-254	SK 3004	RT-120	ECG 102
2N1131	RS276-2021	ICC-51	TR-19	PTC 141	HEP-51	SK 3114	RT-115	ECG 159	ECG 159	GE-53	ICC-254	IRTR-85	PTC 135	HEP-254	SK 3004	RT-120	ECG 102
2N1132	RS276-2021	ICC-51	TR-19	PTC 103	HEP-51	SK 3114	RT-115	ECG 159	ECG 159	GE-2	ICC-631	IRTR-85	PTC 102	HEP-631	SK 3004	RT-120	ECG 102
2N1135	RS276-2021	ICC-51	TR-19	PTC 127	HEP-51	SK 3114	RT-115	ECG 159	ECG 159	GE-2	ICC-632	IRTR-85	PTC 102	HEP-632	SK 3004	RT-120	ECG 102
2N1136	RS276-2006	ICC-232	TR-01	PTC 105	HEP-232	SK 3009	RT-127	ECG 121	ECG 121	GE-53	ICC-633	IRTR-85	PTC 135	HEP-633	SK 3004	RT-120	ECG 102
2N1137	RS276-2006	ICC-232	TR-01	PTC 105	HEP-232	SK 3009	RT-127	ECG 121	ECG 121	GE-2	ICC-634	IRTR-85	PTC 102	HEP-634	SK 3004	RT-120	ECG 102
2N1138	RS276-2006	ICC-232	TR-01	PTC 105	HEP-232	SK 3009	RT-127	ECG 121	ECG 121	GE-9	ICC-2	IRTR-85	PTC 102	HEP-2	NA	NA	ECG 160
2N1139	RS276-2009	ICC-53	TR-21	PTC 121	HEP-53	SK 3122	RT-102	ECG 123A	ECG 123A	NA	NA	IRTR-88	PTC 127	HEP-2	NA	RT-115	ECG 159
2N1140	NA	NA	TR-21	PTC 121	HEP-53	SK 3122	RT-102	ECG 123A	ECG 123A	NA	NA	IRTR-88	PTC 127	HEP-2	NA	RT-115	ECG 159
2N1141	NA	ICC-2	IRTR-89	PTC 107	HEP-2	NA	RT-100	NA	NA	NA	NA	IRTR-88	PTC 141	HEP-641	SK 3025	RT-115	ECG 129
2N1142	NA	ICC-2	IRTR-89	PTC 107	HEP-2	NA	RT-100	NA	NA	GE-5	ICC-641	TR-08	PTC 108	HEP-641	SK 3011	RT-122	ECG 103
2N1143	NA	ICC-2	IRTR-89	PTC 107	HEP-2	NA	RT-100	NA	NA	GE-62	ICC-50	TR-21	PTC 121	HEP-50	SK 3122	RT-102	ECG 123A
2N1144	RS276-2005	ICC-2	IRTR-89	PTC 102	HEP-2	NA	RT-121	ECG 160	ECG 160	GE-11	ICC-53	TR-21	PTC 136	HEP-53	SK 3124	RT-102	ECG 123A
2N1145	RS276-2005	ICC-2	IRTR-89	PTC 102	HEP-2	SK 3003	RT-121	ECG 160	ECG 160	GE-11	ICC-53	TR-21	PTC 136	HEP-53	SK 3124	RT-100	ECG 123

NA = NOT AVAILABLE

continued next month

# THE 1440



## *build it yourself*

*A calculator with memory, square root and other new features*

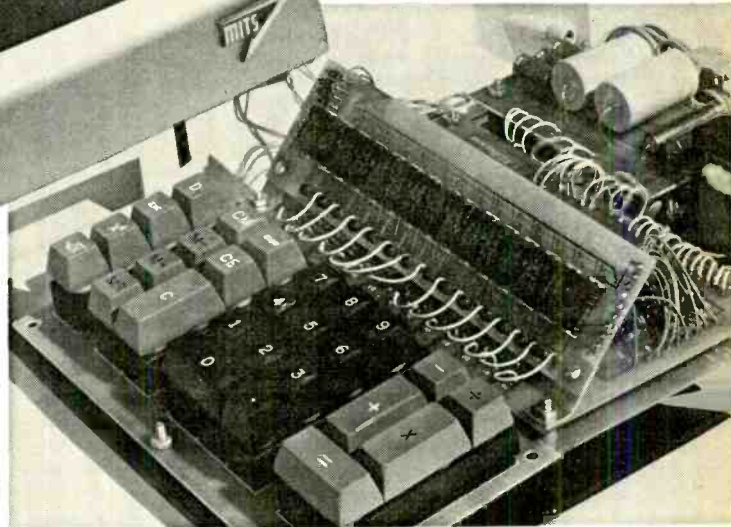

by JAMES R. KELLAHIN\*

FOR THE FIRST TIME EVER, IT'S POSSIBLE for anyone who can operate a soldering iron to assemble an electronic desk calculator with a fully accessible memory. The calculator is the MITS 1400, a commercially available kit, and the memory can store any 14-digit number fed into it.

Memory is but one of this calculator's attractions, since in addition to its ability to handle conventional arithmetic functions it also has keys for square and square root. These valuable keys are equivalent to a book of tables with fourteen place accuracy and instant access.

The calculator has a number of other features, such as built in interface for a printer and programmer, and we'll describe some of them later. But first, let's see how all this operational power is crammed into such a compact package.

As with other machines in the current explosion of pocket and desk electronic calculators, the secret of the 1440 is MOS LSI (Metal Oxide Semiconductor Large Scale Integration) circuitry. The calculator derives its added capability by means of an expanded read-only memory (ROM) containing microinstructions for square root and square operations and a read-write

memory capable of storing and recalling a 14-digit bit.

To see how the various MOS LSI chips are interconnected within the machine, we'll start with the keyboard. Input to the calculator is provided by a quality keyboard consisting of 27 switches connected in an X-Y array.

Depressing one of the keyboard switches generates a start signal which is received by the scanning action of the INPUT chip. This chip serves several roles. In addition to ignoring contact bounce, it locks out further inputs until an initial input has been processed. The chip also encodes input digits into binary format, stores all inputs until the appropriate action key has been pressed, and transmits a six-bit address to the calculator's control ROM for the activation of the internal programming sequence.

The REGISTER chip is the calculators read-write memory. Containing three 16-digit shift registers, an auxiliary 4-bit shift register, and gating logic, the REGISTER chip stores and manipulates inputs, subtotals, and multipliers.

The calculator's arithmetic is performed by the ARITHMETIC chip. This vital chip contains a full BCD (Binary Code Decimal) adder/subtractor, and sign and overflow flip-flops. The ARITHMETIC chip carries out operations to 14-place accuracy.

The calculator's internally stored program is contained in the ROM chip, literally an electronic library. Once the proper address for a microprogrammed operational sequence has been fed into the ROM chip, the chip provides the instructions necessary to cycle the problem through the calculator.

The CONTROL LOGIC chip controls the microprogrammed sequences found in the control ROM chip. The chip includes point-position registers, digit-storage register, iteration counter, and a cycle counter. The counters sample the control ROM to present new instructions as needed.

The OUTPUT chip takes the final results of an operation and supplies the necessary BCD signals for the display and decimal point. The error and sign signals are provided by the ARITHMETIC chip. Digital information is made available to the LED (Light-Emitting Diode) displays simultaneously with 500- $\mu$ s strobing pulses. This multiplexing technique greatly reduces the number of components required to drive the display and permits the LED's to be pulsed with higher than normal current. The higher current levels increase the brilliance of the LED's and the human eye's slow response causes the LED's to appear continually on even though each is on for but 0.5 ms at a time.

\*Micro Instrumentation and Telemetry Systems, Inc.

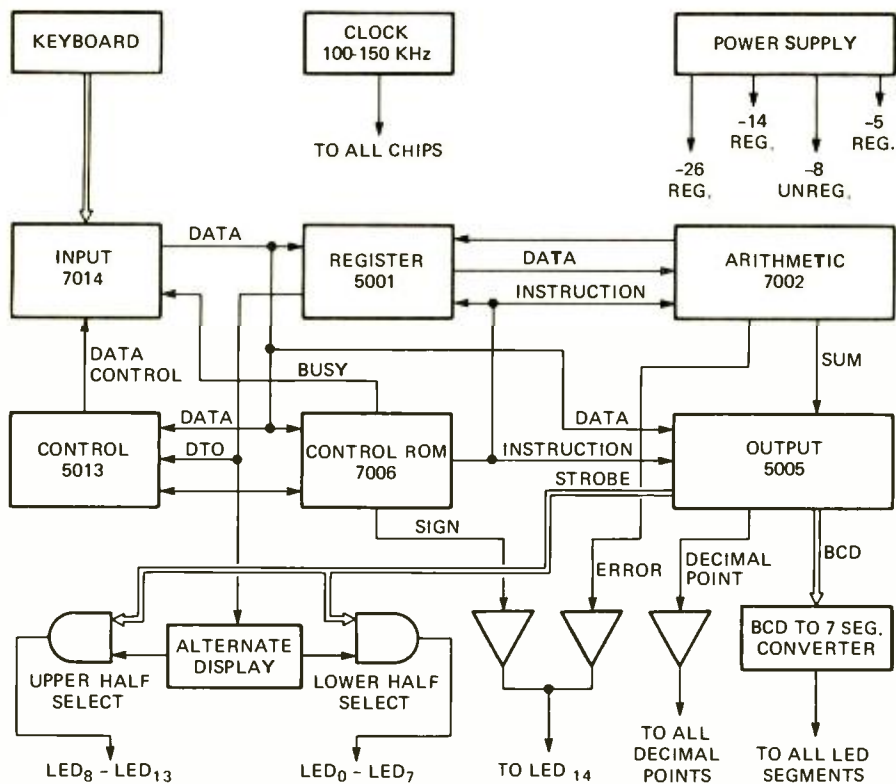

**THE 1440 BLOCK DIAGRAM AND POWER SUPPLY** are at left. The supply delivers one unregulated and three Zener-regulated voltages.

Operations are stepped through the calculator by means of a clock. The 150-kHz clock frequency provides such fast operation that the results of a calculation appear on the display before the operator's finger can be removed from the EQUAL key.

Power for the calculator is furnished by three secondary windings on a custom made transformer. The transformer supplies 8V for the LED's, 14 and 26V for the MOS LSI's, and 5V for the TTL IC's. Regulation is provided by selected Zener diodes.

### Let's put one together

It's not possible to include all the details of assembling the 1440 in the brief space allotted to a magazine article. So we will only skim over the important highlights here. A complete instruction manual does accompany the kit.

Construction of the calculator is straightforward. Probably the most important consideration is good soldering practice, since sloppy soldering will result in cold connections and possibly solder bridges.

The machine uses four circuit boards which are mounted to a common frame when their assembly is complete. First to be assembled is the CAPACITOR BOARD. This small board contains the seven power supply filter capacitors and is the easiest to complete.

The DISPLAY DRIVER BOARD is assembled next. This board contains 22 transistors, 6 diodes, 37 resistors, and 5 IC's. The transistors are soldered in place, but the IC's plug into low profile sockets. The sockets are quickly soldered to the board and protect the IC's from soldering heat and simplify servicing.

The LED BOARD contains 15 LED digital displays, 14 transistors, and four resistors. It's interesting to note that all but one of the calculator's transistors are 2N2907's. The LED displays are all installed in place and aligned for straightness before being soldered in place. Incorrect installation is impossible, since the LED leads can only be inserted into the board one way.

The final circuit board to be assembled is the MAIN BOARD. This board contains the power supply circuitry, the clock, and the six MOS LSI chips which form the calculator's central processing unit. As with the other boards, assembly is straightforward. A major precaution, however, is to press a sheet of aluminum foil against the rear of the board when inserting the

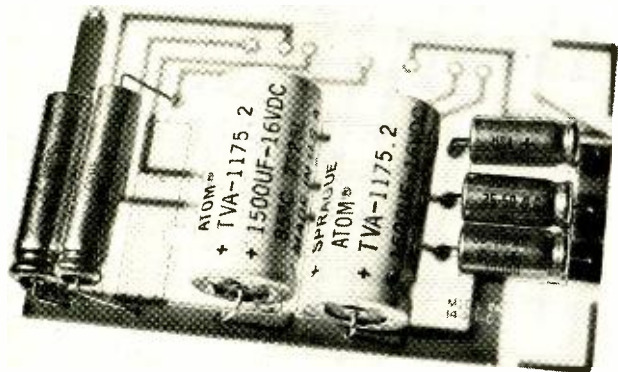
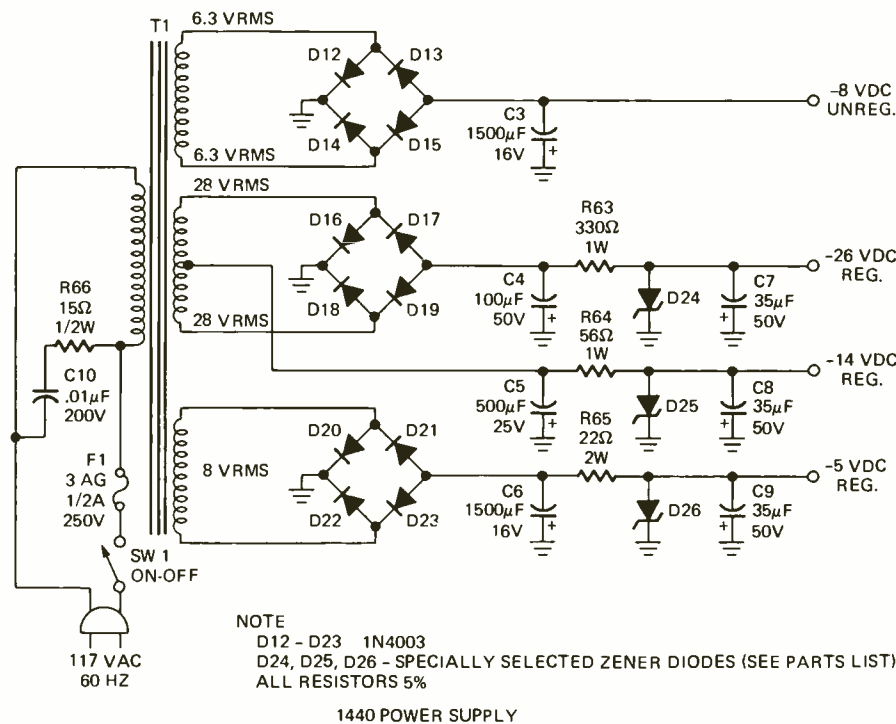

**PHOTO OF CAPACITOR BOARD.** This is the simplest and easiest of the four circuit boards to wire. The seven electrolytic capacitors are used as power supply filters.

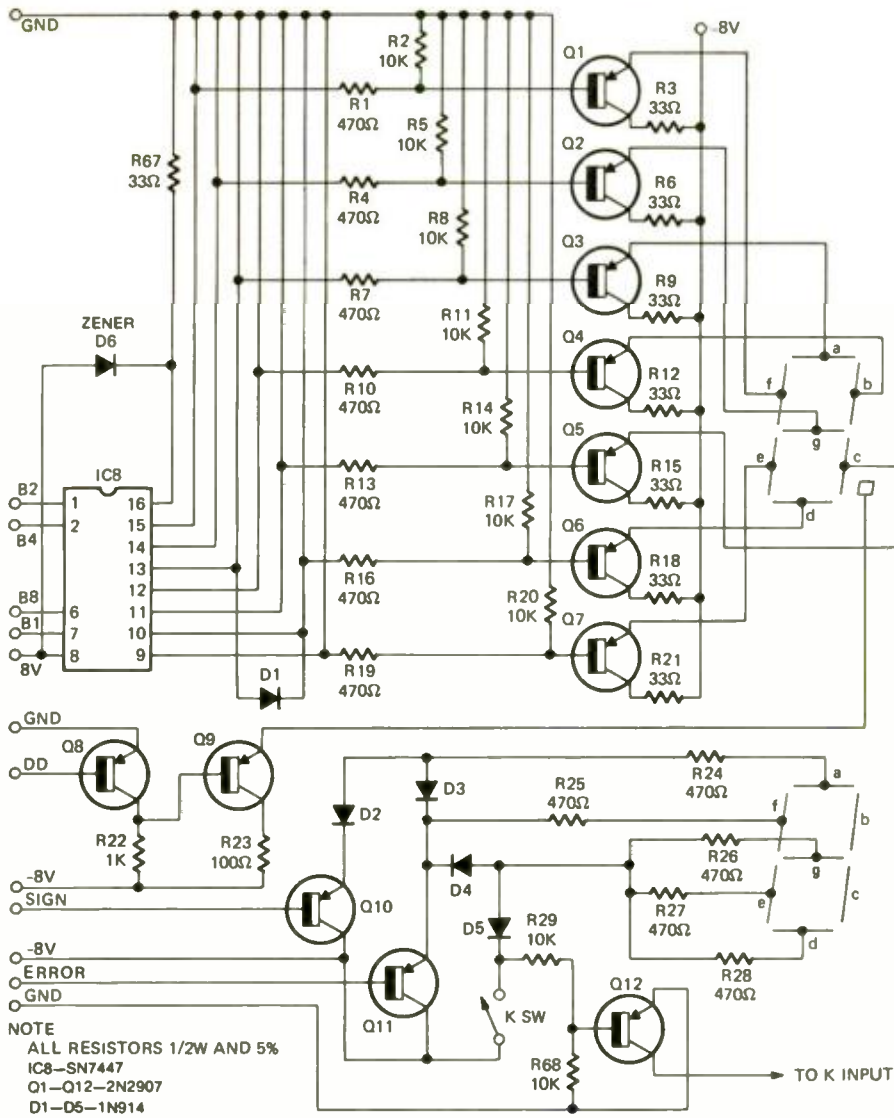

1440 DISPLAY SCHEMATIC

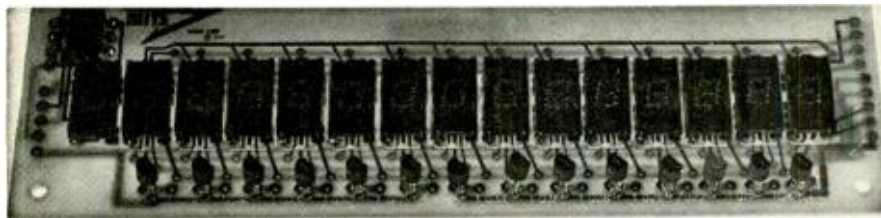

SCHEMATIC OF A BASIC DISPLAY and photo of the assembled display board. There are 15 LED's, fourteen are numeric readouts. The other is for "E" for error and "C" for constant signals.

six LSI IC's into their sockets. This prevents the possibility of static electricity damaging the MOS structure of the IC's by shorting all the pins of each IC to one another.

The four calculator boards are connected to one another by the interconnect leads soldered to each board during preliminary assembly. The boards are then mounted to the calculator's base plate and the keyboard is connected. Before the case is attached the calculator must be thoroughly inspected for possible wiring errors, solder bridges, and bits of stray wire clippings. Then the line cord is plugged in and the power switch acti-

vated for a preliminary operational check. If everything works normally, the case is installed and the calculator is complete.

**Using the 1440**

Since operations are fed into the calculator algebraically, using the 1440 is as easy as writing a problem out on a sheet of paper. The machine is cleared of all former entries and ready for use as soon as the power switch is activated. The machine can be cleared at any time by simply pressing the C key. To clear an incorrect entry only (and not the memory), press the CE key.

The decimal point can be shifted by simply pressing the D key and any of the digits 0-7 simultaneously. The decimal point will automatically move to the desired position.

Improper operations, such as square root of a negative number, are indicated by the error signal E on the LED display. The E signal also indicates when too many digits have

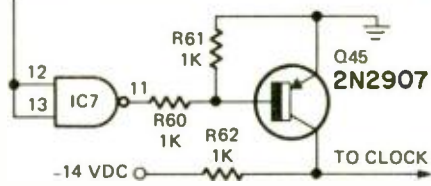
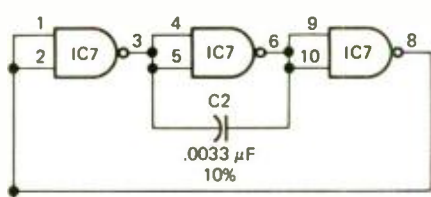
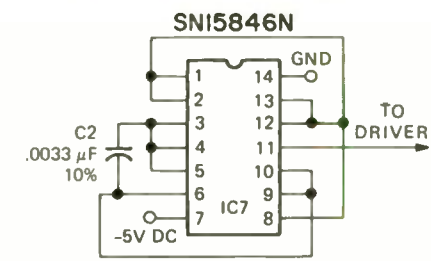

NOTES  
NOMINAL OUTPUT FREQUENCY 130 KHz  
ALL RESISTORS IN OHMS  
ALL RESISTORS 1/2W, 5%

1440 CLOCK

THE CLOCK IN THE 1440. Wiring of the clock IC is shown at top while block diagram and schematic are shown below.

been loaded into the machine.

To perform standard arithmetic with the calculator, the keyboard is operated in a logical sequence. Since each key has a single function, no special keyboard manipulations are required as with some commercial calculators on the market. Use of the memory is as simple as pressing the appropriate keys. To store a number in the memory, simply enter the number on the keyboard and press M+. The number can be recalled at any time by pressing MR. Numbers can be added or subtracted from the memory by using the M+ and M- keys.

Flexibility of the 1440 is enhanced by the EXC key. This feature permits the two numbers of an operation to be exchanged with a single key stroke, a particularly valuable feature when the memory is being used.

The 1440 is available as a kit for \$199.95. A completely assembled and ready to use unit is \$249.95. The assembly and instruction manual that comes with the kit is available separately for \$3.

R-E

# R-E's Service Clinic

## IC's, TV, and you

How to handle these  
black boxes

JACK DARR  
SERVICE EDITOR

WE'RE RUNNING INTO MORE AND MORE SETS using IC's lately. They have been "in and out" of quite a few makes, even the "un-modular" jobs, for the past couple of years. As usual, we take the things they throw at us, and develop test methods and equipment to cope with 'em. Let's look at a few Do's, and some pretty important Don't's in this kind of work.

I'm not going to try to go into the internal construction of IC's. For one thing, this data is generally unavailable, and wouldn't be of much help even if we did have it. A schematic of the innards of an IC is pretty useless. So we go back to one of the oldest concepts in electronics—John F. Rider started it back in the early 1920's. Plain old signal tracing.

The IC is a sealed unit—a real Black Box. Some service manuals actually refer to the terminals as "connections to the *outside world*." So we have two ways of attacking the problem. Signal tracing, or "signal in vs signal out," and dc voltage readings. In my opinion, we should always use both of them; one to verify the data from the other. If we have normal signal in, and no signal or abnormal signal out, this is a good clue that there is something wrong in between.

Dc voltage tests are useful, if correctly interpreted. The majority of IC's seem to use one terminal as the power input. Internal connections distribute it to the jillions of parts inside. In all that I've run into so far, there will be several other terminals which show dc voltages. These come from the IC, through transistors and resistors, etc. These are a valuable clue.

So here we can get a small handle on the problem (The problem, in most cases being "Is the IC working?"). If we have the normal dc voltage at the power-input terminal, and the normal dc voltages on terminals where it should be, this could mean that the IC itself is working. For verification, scope the signals at the signal-in and signal-out terminals.

For one example, in a color demodulator IC, the normal input signal would be the reference oscillator signal, on at least two inputs, and the output would be the three color signals. Find out which terminals these are applied to, and where they come out. Check for proper peak-to-peak voltage, and waveform. These are given a lot of schematics, and should be given on all of them.

Let's say that we find normal inputs;

plenty of 3.58-MHz oscillator signal, color signal from the bandpass amplifier OK. So we go and look for the three color output signals. The output waveforms of these, by the way, will still be the familiar "Lazy-S" or rocker shapes that we've been seeing all along. If the set uses the old "video, to cathodes, color to grids" circuit, they'll be exactly the same. In the "RGB" circuit, where color and video are fed to the cathodes, the patterns will be inverted, but still of the same shape. When making these tests, always use a color-bar signal on the input so that you'll have a fixed, recognizable pattern.

If the dc voltages are normal but signals are abnormal, check any external parts that are connected to that terminal. For example, in one circuit the three color signals come out through a resistor and capacitor. An open resistor or shorted capacitor could upset the signals, and not have too great an effect on dc voltages. If you find two normal color outputs, and one is zero, and the external parts are OK, this would be a definite indication of IC trouble.

In one typical set, the supply voltage is +12 volts. On the three color signal output terminals, dc voltages of about 5.6 volts are developed inside the IC, on each of the terminals. If two of these are normal, and the other zero, or 12 volts, this, too means internal trouble. Be *sure* to check for anything *external* which could cause this, first; a solder bridge, shorted capacitor, and so on.

### Test equipment and methods

I believe that the minimum test equipment you'll need for this kind of work will be a bar-dot generator, a good scope, and a vom with a very high input impedance: either a FETVM or vtvm. The voltages won't be very high. So, the voltmeter should have a couple of good low-voltage ranges; say 0 to 2 and 0 to 10 volts, capable of being read to within tenths of a volt. A wideband triggered-sweep scope makes things very handy. However, older scopes can do the work, if properly operated.

One of the most important things in this kind of work is the *test prods and probes* on your equipment. You simply can not use the old type "phone-jack" test-prods on the closely-spaced pins of an IC with safety. Pin spacing of a 14 or 16 pin DIP (Dual-In-Line Package) IC is only a few *thousandths* of an inch, and the old tips cover two or three at once. If you short two

This column is for your service problems—TV, radio, audio or general and industrial electronics. We answer all questions individually by mail, free of charge, and the more interesting ones will be printed here.

If you're really stuck, write us. We'll do our best to help you. Don't forget to enclose a stamped, self-addressed envelope. Write: Service Editor, Radio-Electronics, 200 Park Ave. South, New York 10003.

adjacent pins, the results are apt to be disastrous.

For maximum safety, use needle point test prods. I've noticed that a lot of test equipment makers are providing very sharp pointed prods on the late models, equivalent to the needle-point prods. These, of course, have been around a long time. You can change your present equipment for needle-points, with no trouble. Somewhere, I have seen a slip-on adapter for the old prods, with a needle-point.

Your testing-methods are going to have to change, too. No more happy jabbing in the general area of where you want, and hoping you hit it. When you take voltage readings on an IC socket, steady your hand on the chassis, and bring that tip down very carefully on the terminal.

If you can rest your hand on the chassis, this helps. If they have thoughtfully provided a couple of hot terminals right where you want to go, put a small piece of foam plastic over them. Get a piece about an inch thick. This should be enough to insulate you, and also help to keep you from knocking over heat-sink tabs on transistors, and other stuff that's near the area where you want to work.

One final thing. We're used to counting tube-socket pin numbers clockwise, from the bottom of the chassis. The round-can IC's (TO-5 case with up to 10 pins) still count in this way, but you seldom work from the bottom. The DIP packaged IC's are numbered *counterclockwise, from the top*. Start with the IC set so that the locator notch on the case is to your left, with the long side of the case parallel to you. Now, go *down* and start with the left pin. This is No. 1. Count along the bottom row, then turn the corner, go up, and keep counting until you get back to where you began. This is easier to show than describe (see diagram).

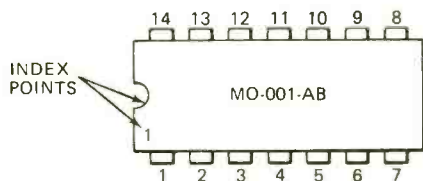

TOP VIEW OF a DIP type IC. In some cases pin 1 is marked by a dot or the maker's symbol.

As I said in the beginning, these are all "new and different" to most of us. However, I still have my abiding faith in the American service Technician. We've taken everything they have thrown at us, in stride, without missing a step, and we'll do the same thing with these Little Monsters. **R-E**

## reader questions

### POOR COLOR LOCK

*I've worked over this Magnavox T920 color set pretty well and it runs fairly well now. Only problem is a "loose" color sync. If I flip the tint control back and forth, I can get it to lock*

*and it stays in for quite a while. What could be the cause?—H.W., San Jose, Calif.*

There are a couple of things. One is a slight unbalance in the afc diodes. Check for equal dc voltages, opposite polarity. Should be somewhere around 50 volts.

Another and sometimes more puzzling thing is a crystal that's just a wee bit "off". Good check for this: read the dc voltage on the grid of the reactance tube with a color bar pattern on the set, and locked in.

The voltage here should be zero. Now move the core of the reactance coil about one turn in either direction. You should be able to make this voltage *swing* positive one way and negative the other. With a perfect crystal,

the dc voltage here will swing about 4 to 5 volts in each direction. If you find that the voltage will swing about 8 to 9 volts in one direction, but will not "cross zero" and reverse the polarity, change the crystal.

### LOW HIGH VOLTAGE, GOOD BOOST

*After changing the flyback in an RCA CTC-11 I get pretty good sweep, and normal boost voltage. However, if I turn the brightness up very far, the picture gets fuzzy and smears. Cathode current of the 6DQ5 is normal.—F.H., Allentown, Pa.*

Something in the high-voltage rectifier. Probably a weak 3A3. You've got plain old blooming and your new flyback is working fine. How do I

# Earn Your Electronics DEGREE mainly by studying at home.

Grantham School of Engineering specializes in teaching electronics and supporting subjects, mainly by correspondence. The School is authorized under the laws of the State of California to grant academic degrees, is approved under the G.I.Bill, and is accredited by the Accrediting Commission of the National Home Study Council.

The A.S.E.T. degree is offered entirely by correspondence. The B.S.E.T. degree is offered thru additional correspondence and certain transfer credits plus a one-week residential seminar. Then, the B.S.E.E. degree is available thru further residential attendance. Ask for our free BULLETIN B-73.

## GRANTHAM School of Engineering

1505 N. Western Avenue  
Hollywood, CA 90027

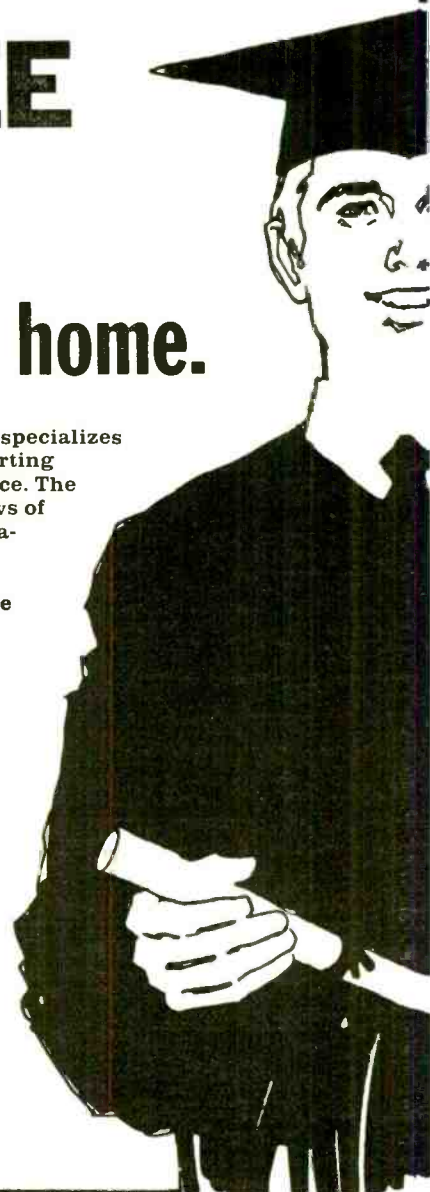

know? Because your *boost* voltage and the cathode current of the 6DQ5 are normal. This means that your "source" (flyback, tube, B+) is in good shape.

You have several outputs from the horizontal output stage; sweep, boost, focus, high voltage. If any one of these is normal, the circuit is working. The trouble is in only those parts in the output that aren't normal; here the high-voltage rectifier.

#### MISSING TUBE, SWEEP ANALYZER

*I have a Wintronix Model 820 Sweep Analyzer with a tube missing. It's got a 12AU7 and a 6X4, but the other one's gone. Has a plate cap. What is it?—A.G. Millville, N.J.*

That's a 6BQ6. It's used to generate pulses to feed the bridge circuit in this analyzer.

#### NO COLOR, NO PICTURE

*This Truetone MIC 4218A color set has a screwy symptom. The picture looks very odd with the color turned full up. If I turn the color off, I get no picture at all, just a blank raster. Contrast control has no effect.—R.H., Hope, Ark.*

You've already found it. A color picture is actually *two* pictures, one on top of the other. One nothing but colors, the other nothing but black and

white. Both of them have to be there. You've lost the black & white picture *completely*.

Color in this set is picked off after the emitter-follower first video amplifier. So things are OK up to this point. From here the video signal goes through a plug and socket to the emitter of the second video amplifier transistor (common-base circuit). Then it goes through the delay line and contrast control to the grid of the 10GK6 third video amplifier. Somewhere in this section of the set it stops. Happy hunting.

#### MORE FIELD-FEEDBACK ON FLYBACK

Roy Fischel of Chicago, Ill. writes, "In answer to your letter about the Zenith 23XC38 chassis, with the vertical bars in the raster, I moved the horizontal output tube plate connection from the original terminal to terminal 8, as you suggested. Remember, you told me that you wished you'd done that, but did not think of it until too late? Well, I tried it, and it reduced the bars to only two. However, I did have to replace the flyback to get rid of them all."

Thanks, Roy. I wondered about that, and now I know. (I wasn't about to put the old flyback in again to find out, though.)

#### BIAS TRANSFORMER, ECHO DEVICE

*I have an electronic echo-device which records the signal on a continuous tape, then picks it off again, at a variable interval. It's an "Ecco-Fonic", Model E, and that's all the information I have. The bias oscillator transformer is open. Where can I get a replacement?—R.S., Alamance, N.C.*

A Nortronics T-60 series transformer should do it. It's almost a universal type and can be connected for any of several frequencies. There are both tube and transistor types.

#### EXTENSION SPEAKER

*The owner of this RCA XL-100 wants to use a pillow speaker with it. Can I add one without damaging the output stage?—J.H., Aspers, Pa.*

Yep, if you're careful. This set has an OTL circuit (Output-TransformerLess) and you can add extension speakers. However, you must be sure that the extension speakers are at least as high impedance as the original. Do not, *repeat NOT* use speakers with a lower impedance. The original is a 32-ohm type.

You can connect it with a simple circuit-breaking phone jack, or a spdt toggle switch. Suggestion: you won't need a great deal of power output with a pillow speaker. If your pillow

# INTERNATIONAL Frequency meter FM-2400CH

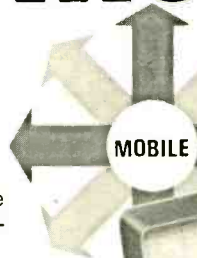

The FM-2400CH provides an accurate frequency standard for testing and adjustment of mobile transmitters and receivers at predetermined frequencies.

The FM-2400CH with its extended range covers 25 to 1000 MHz. The frequencies can be those of the radio frequency channels of operation and/or the intermediate frequencies of the receiver between 5 MHz and 40 MHz.

Frequency Stability:  $\pm .0005\%$  from  $+50^\circ$  to  $+104^\circ\text{F}$ .

Frequency stability with built-in thermometer and temperature corrected charts:  $\pm .00025\%$  from  $+25^\circ$  to  $+125^\circ$  (.000125% special 450 MHz crystals available).

Self-contained in small portable case. Complete solid state circuitry. Rechargeable batteries.

**WRITE FOR CATALOG!**

- Tests Predetermined Frequencies 25 to 1000 MHz
- Extended Range Covers 950 MHz Band
- Pin Diode Attenuator for Full Range Coverage as Signal Generator
- Measures FM Deviation



FM-2400CH (meter only).....	\$595.00
RF crystals (with temperature correction) .....	24.00 ea.
RF crystals (less temperature correction) .....	18.00 ea.
IF crystals.....	catalog price



CRYSTAL MFG. CO., INC.  
10 NO. LEE • OKLA. CITY, OKLA. 73102



speaker is an 8- or 16-ohm type as a lot of them are, just add enough series resistance to bring the total up to 32 ohms or more. You'll lose some power, but it won't matter.

#### NO I.F. GAIN

*After I finally cleared up all of the shorts in this old Hallicrafters S-52 multi-band receiver, I got a signal through the audio. However, I can't get an i.f. or rf signal through from anywhere. Tubes good, dc voltages look fairly close.*

*I get about 75 volts on the plates and screens of the i.f. and rf tubes, grids about 1.5 volts, and cathodes about 24 to 26 volts. This has an odd cathode circuit. Any ideas?—G.M., Greensboro, N.C.*

I've been stuck on the same thing. Simple, if you know it's there. Tough, if you don't. It's not a "stock" circuit. The diagram shows the cathode circuit. There's a 10,000-ohm SENSITIVITY control in series with the 6SG7 rf amplifier, as well as the two 6SK7 i.f. amplifier cathodes. By changing the setting of this, you vary the cathode bias on all three tubes, thus changing the sensitivity.

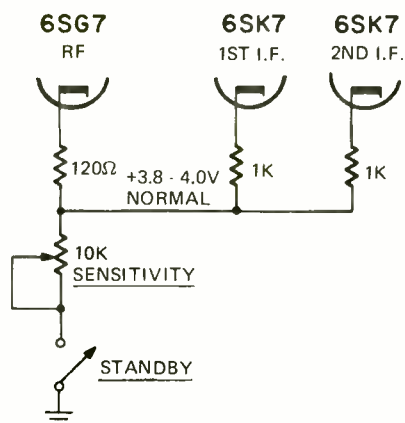

**SENSITIVITY OR RF GAIN CONTROL circuit**  
In a typical all-wave receiver

If you'll notice the high cathode voltages you found, you'll see that these are high enough to cut the rf and i.f. tubes completely off. Normal dc voltages here should be 3.8 to 4.0 volts. (Positive voltage on a cathode is the same as negative voltage on a grid.)

Try adjusting the sensitivity control, to see if you can get the bias back to normal. If it won't vary at all, the STANDBY switch, in series with the ground-return of the sensitivity control, is probably open. This cuts off the rf stage and i.f.'s when you're transmitting.

#### COLORS REVERSED

*This Zenith 16Z7C17 shows a complete reversal of the colors. Blues on the left, green in center and red on the right. Color bars also miss the black-*

*and-white bars by about half, falling in the slots. I've checked and aligned the color circuits, and everything I can think of, with no results. What is it?—L.G., Chicago, Ill.*

A phasing problem. Either the color signals or the reference oscillator must be way out of phase. This is the only thing that could cause such a tint-shift. Check, by replacement, that little phase-shift coil in the 3.58-MHz oscillator output; it is L34 in the Sams schematic.

If it is shorted, it can upset the normal phase shift very badly. It has been known to do this. Try a new one.

#### 5U1 FOR 5DEP1 CRT?

*I have a KG-635 Knight scope with a bad 5DEP1 CRT. I've got a new 5U1 CRT; will it work?—F.B., Chicago, Ill.*

I believe so. The two tubes have exactly the same basing and as nearly as I can tell, the same heater voltage and current. Knight used a 5U1 tube in their KG-630 scopes.

#### NO RECORD, LEFT CHANNEL

*This 10-year old Knight tape recorder is OK on playback, both channels. On Record, the right channel is good, but the left channel is low and garbled. Tubes OK, dc voltages seem normal.—C.M. Whittier, Calif.*

Good playback both channels means that the tape heads are very apt to be OK. Good record on one channel means that the bias oscillator is working. Low output and garbled sound on only one channel looks very much as if you're not getting the bias to that head.

This would most likely be some accidental short or open in the wiring or in the switching to that head. Follow the signal through to the head with a scope and you'll see it.

#### ODD COLOR PROBLEMS

*This 20X1C38 Zenith has intermittent "odd-color" problems. I notice on a tube-test that the 6JU8 tube has quite an unbalance between sections.—T.D., Franklin, Mich.*

You've got it. Replace that 6JU8. Unbalance and other odd troubles, including mount-contamination, in this tube can cause more weird troubles than you can shake a stick at. This should fix it. (Field feedback from a puzzled reader; it did.)

#### SHORTED SCOPE TRANSFORMER

Mr. S.J. Martin, of Camden N.J., sends along this cute idea for fixing a short in a scope power transformer. He says, "The intensity control kept burning up on an old model Heathkit  
(continued on page 66)

# Reduce Car Maintenance Increase Engine Performance.

Put a Mark Ten Capacitive Discharge Ignition (CDI) System On Your Car.

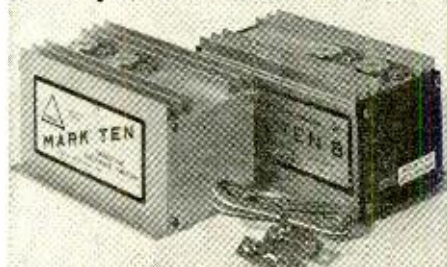

Even Detroit finally recognizes that electronic ignition systems dramatically increase engine performance. Chrysler is now putting them on their new models. The Mark Ten CDI, the original electronic ignition system, has been giving increased performance with lower maintenance to hundreds of thousands of satisfied customers for over eight years. Install a Mark Ten CDI on your car, boat or truck and eliminate 3 out of 4 tune-ups. Increase gasoline mileage up to 20%. Enjoy improved engine performance. Or put a Mark Ten B on your car. It was especially designed for engines with smog control devices. By reducing combustion contaminants, the Mark Ten B restores power losses caused by these devices. Equipped with a convenient switch for instant return to standard ignition, the Mark Ten B is applicable to ANY 12 volt negative ground engine. Both systems install in 10 minutes with no rewiring. Order a Mark Ten or Mark Ten B CDI today.

Mark Ten (Assembled)	\$44.95 ppd.
Mark Ten (DeltaKit)	\$29.95 ppd.
<small>(Kit available in 12 volt only positive or negative ground.)</small>	
Mark Ten B	\$59.95 ppd.
<small>(12 volt negative ground only)</small>	

Superior Products at Sensible Prices  
Mfg. in U.S.A.



Dept. RE  
**DELTA PRODUCTS, INC.**

P.O. Box 1147 / Grand Junction, Colo. 81501  
(303) 242-9000

Please send me free literature.

Enclosed is \$\_\_\_\_\_  Ship ppd.  Ship C.O.D.

Please send:











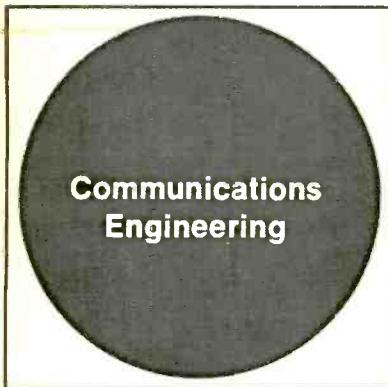

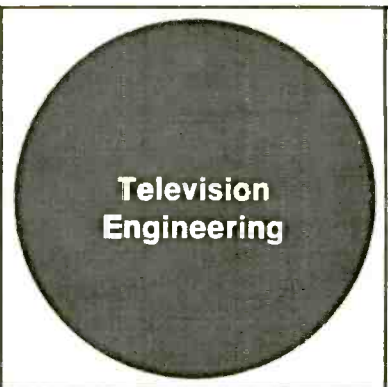
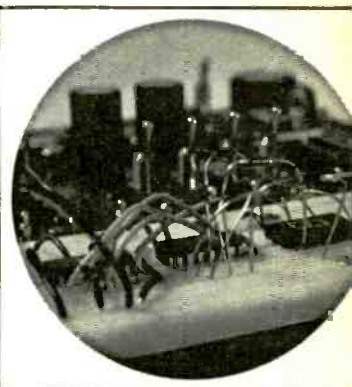
- \_\_\_ Mark Ten B @ \$59.95 ppd.
- \_\_\_ Standard Mark Ten (Assembled) @ \$44.95 ppd.
- \_\_\_ 6 Volt: Neg. Ground Only
- \_\_\_ 12 Volt: Specify
- \_\_\_ Positive Ground \_\_\_ Negative Ground
- \_\_\_ Standard Mark Ten (DeltaKit®) @ \$29.95 ppd. (12 Volt Positive Or Negative Ground Only)

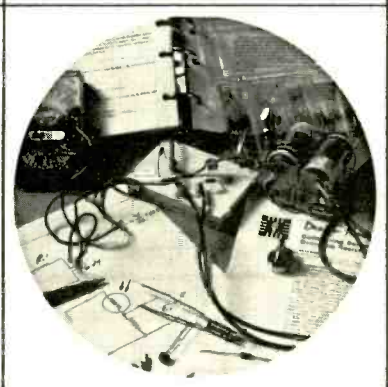
Car Year \_\_\_\_\_ Make \_\_\_\_\_

Name \_\_\_\_\_

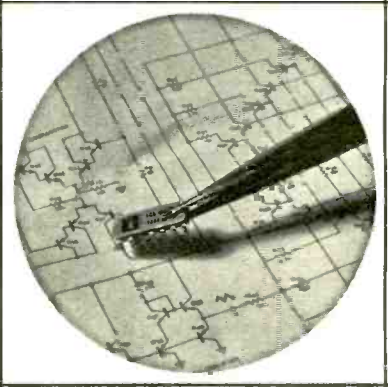
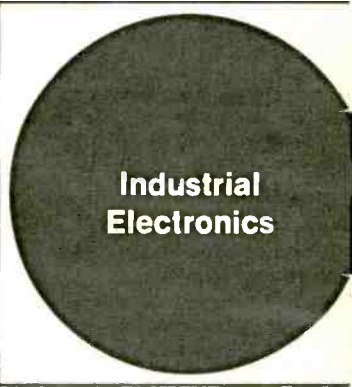
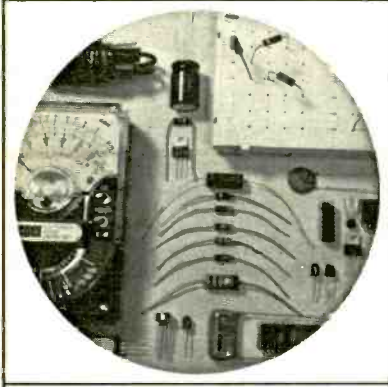
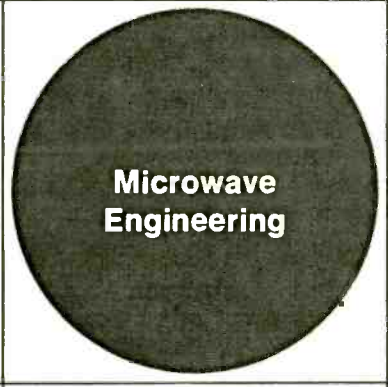
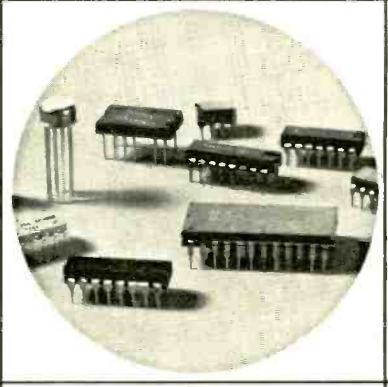
Address \_\_\_\_\_

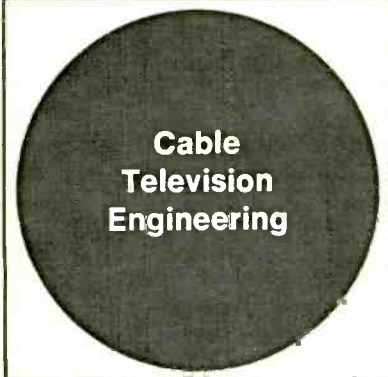
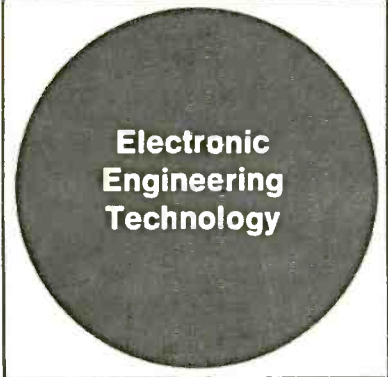
City / State \_\_\_\_\_ Zip \_\_\_\_\_

 <p><b>Communications Engineering</b></p>	 <p><b>Aeronautical &amp; Navigational</b></p>	 <p><b>Television Engineering</b></p>	
 <p><b>Automatic Control Engineering</b></p>		 <p><b>Missile &amp; Spacecraft Guidance</b></p>	
 <p><b>Radar &amp; Sonar Engineering</b></p>	 <p><b>Digital Communications</b></p>		 <p><b>Industrial Electronics</b></p>
	 <p><b>Microwave Engineering</b></p>		 <p><b>Satellite Communications</b></p>
 <p><b>Cable Television Engineering</b></p>	 <p><b>Electronic Engineering Technology</b></p>	 <p><b>Nuclear Instrumentation &amp; Control</b></p>	 <p><b>Special Programs for Electronic Engineers</b></p>

ADVANCED ELECTRONICS CAREER TRAINING AT HOME

Computer Engineering

If you are too busy to go to college to learn advanced electronics, CREI brings college level training to you. CREI programs give you practical engineering training that you can apply in your work to move ahead to higher paying jobs. And CREI lets you specialize in exactly the area of electronics you want. You have a choice, depending on your qualifications, of 18 different programs.

Not only are CREI programs college-level but arrangements are available for you to earn college credit applicable to advanced degrees.

# Only CREI offers you a choice of 18 programs in advanced electronics

Electronic Systems Engineering

For over 45 years CREI programs have been recognized by leading technical organizations as effective home study training in advanced electronics.

### NEW OPTIONAL LAB PROGRAM



CREI now offers a supplementary ELECTRONIC DESIGN LABORATORY PROGRAM to make learning advanced electronics easier and to give you actual experience to use in your work. Only CREI offers this complete college type laboratory program. You learn to actually design electronic circuits. At the same time you get extensive experience in tests and measurements, breadboarding, prototype building and other areas important to your career.

**Qualifications to Enroll.** To qualify for enrollment in a CREI program, you must be a high school graduate (or equivalent). You should also be working in electronics or have previous training in this field.

**Send for FREE book.** If you are qualified, send for CREI's newly published book describing your career opportunities in advanced electronics. This full color book is filled with facts about career opportunities for you.

Nuclear Engineering Technology



Accredited Member, National Home Study Council

CREI, Dept.  
3939 Wisconsin Avenue  
Washington, D. C. 20016

Rush me your FREE book describing my opportunities in advanced electronics. I am a high school graduate.

Name \_\_\_\_\_ Age \_\_\_\_\_

Address \_\_\_\_\_

City \_\_\_\_\_ State \_\_\_\_\_ ZIP \_\_\_\_\_

If you have previous training in electronics, check here

Employed by \_\_\_\_\_

Type of Present Work \_\_\_\_\_

Veterans and servicemen, check here for G. I. Bill information

# CREI

CAPITOL  
RADIO  
ENGINEERING  
INSTITUTE

A Division of McGraw-Hill  
Continuing Education Co.  
3939 Wisconsin Avenue,  
Washington, D. C. 20016

Special Programs  
for  
Non Electronic  
Engineers

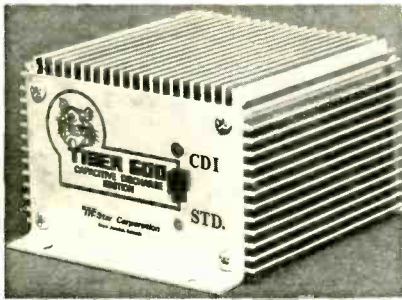

## 12 REASONS YOUR CAR NEEDS A TIGER 500

Instant starting in any weather - Eliminates tune-ups - Increases gas mileage - Increases horsepower 15% - Improves acceleration & performance - Spark plugs and points last up to 70,000 miles - Reduces engine maintenance expense - Amplifies spark plug voltage to 45,000 volts - Maintains spark plug voltage to 10,000 RPM - Reduces exhaust emissions - Dual ignition switch - Unconditional guarantee for original owner - Installs in 10 minutes on any car with 12 volt negative ground - No rewiring - Most powerful, efficient and reliable Solid State Ignition made.

SATISFACTION GUARANTEED  
or money back.

Assembled ..... \$49.95  
Post Paid in U.S.A.

Send check or money order with order to:

**Tri-Star Corporation**

Dept. R, P. O. Box 1946  
Grand Junction, Colorado 81501  
DEALER INQUIRIES INVITED  
Circle 13 on reader service card

## CLINIC QUESTIONS

(continued from page 61)

scope I bought as-is. Finally found that the pix-tube heater winding was leaking to ground. Everything else on the power transformer was OK.

So I connected a standard TV "isolation" type brightener into this circuit, set on isolate, not boost. Worked fine!"

Thanks S.J. I was going to suggest a separate 6-volt filament transformer, but this is probably easier to install and more compact. Good idea.

## IC LIFTER

*What's the easiest way, if any, of getting IC's out of their sockets? I broke one today when those wee little pins hit my thumb.—M.R., St. Petersburg, Fla.*

The best gadget I know of is the little one that I got with a Heathkit. Just a piece of 1/16 thick sheet metal, a bit less than 1/4 inch wide. Just enough to let it slip between the pins of a DIP package IC. Bend one end to a right angle, about 1/2 inch long. The other end can be any length you want as in the sketch.

To use it, slip the short end under the IC and carefully pry one end up. Then pry the other end up by moving the handle the other way. You can "rock" it up out of the socket a frac-

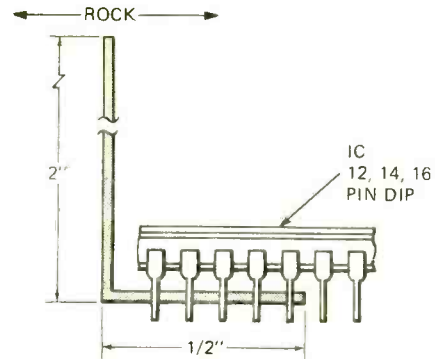

THE SIMPLEST IC LIFTER. Other types help you get IC's back in their sockets

tion of an inch at a time, without bending any pins.

The Techni-Tool people make a plier-like device with jaws, which is also very handy.

## PICTURE TUBE HEATER WON'T LIGHT

*The heaters of the picture tube won't light, in this RCA CTC-38. The picture tube is good on a tester. The power transformer gets pretty hot. Do you think the transformer is shorted?—J.G., Mena, Ark.*

Not yet. Take the 6.3-volt heater leads, from the power transformer, loose; the picture tube heaters are fed from a "dc biased" winding on the power transformer. A bias of +195 volts dc is connected to this heater, see diagram, to reduce the chance of H-K shorts. These are the green and green-yellow wires. Now turn it on and read the ac voltage across this winding.

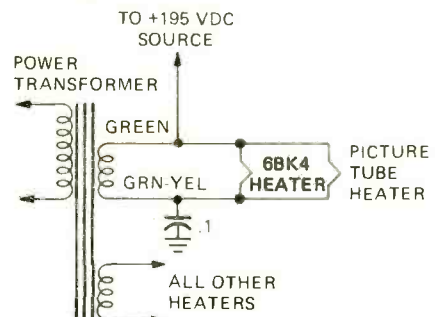

PICTURE TUBE HEATER IS BIASED by a fixed dc voltage to reduce heater-cathode stress.

If it is OK, check the 6BK4. Its heater is also fed from the same winding. In a few cases, this tube has shorted and overloaded the picture-tube heater winding. This will also make the transformer run very hot. While you're at it, look out for accidental wiring shorts across this winding. In a few models, the second i.f. tube heaters are also connected here.

## FOCUS TROUBLE

*This Philco 18QT85 has a focus problem. The focus coil doesn't seem to react at all. Focus is poor, although everything else seems to be OK. Can you*

## RANGE 73

**Optional "Portfolio style" carrier.** Besides carrying Range 73 parts or tools, uniquely unfolds flat to four times its own size (from 6"x16" to 24"x16") and converts into a pod protector for TV cabinet top when on service calls.—Net \$4.95

**A useful unit for field or bench servicing.** Includes a powerful and flexible spotlight mounted on a rigid Poly Sources Body, with Standard and polarized interlocks. When plugged into a TV or any other chassis it provides AC power to them and automatically supports itself, allowing illumination to any part of the chassis being repaired. It eliminates

**bench or flash lights and standard or polarized cheater cords.** Also includes a built-in AC outlet for any auxiliary feeding or extension. As the entire unit is made of high voltage insulating materials, it allows close-ups of "hot" areas of a TV chassis. When not plugged into a chassis it can be used conveniently by placing in any position or twisted, looped, hung or inserted in almost any place by the special head, neck or body. Its compactness and safety designs allow seeing and inspecting among transistorized and IC components, or even "X Raying" Solid State Printed Circuit Boards. Price — \$9.95 Net

Spotlight ext. to 21 in. • Head dia. 3.4 in. • Bulb: 115V (SP) • Power cord: 7 ft. • Weight: 7 oz. • Color: black.

Please mail check or money order "RANGE 73" — Net \$9.95, Optional Carrier Net \$4.95 (Add \$1.00 for shipping) (Calif. resident 5% tax) OR: Mail Only \$5.95 with order, balance plus shipping on C.O.D.

Circle 14 on reader service card

tell what's causing this?—V.T., San Leandro, Calif.

We'll get close. If your boost voltage and width are normal, and high voltage is close to normal, then the focus circuit has the normal "supply". This is the 5-kV pulse developed at the plate of the horizontal output tube. So your trouble will be in one of the 5 parts inside the dashed line in the sketch.

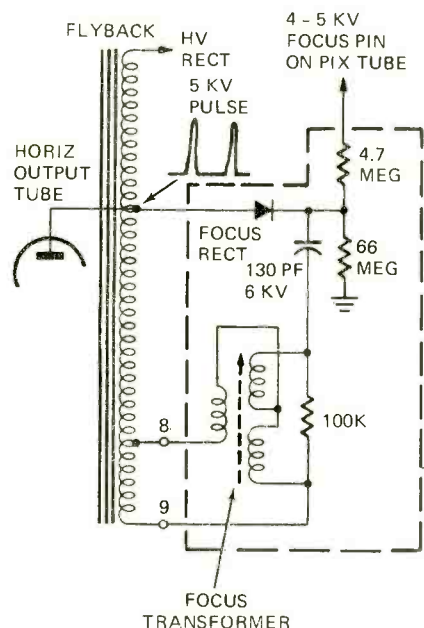

**TROUBLE IN FOCUS CIRCUIT** may be due to defect in a part within the dashed lines.

If your focus voltage is low, try a new focus rectifier. If the focus voltage is high and the focus adjustment has no effect at all, the focus transformer may be open. (If it is shorted, it will load the flyback very heavily.) A focus voltage that is too high or too low will cause defocusing.

### WEAK VIDEO

With a new picture tube in this Silvertone 8175, convergence, color, and so on are good, but the video is very weak, apparently. The picture is clear, but pale and washed-out looking. Agc works, but won't clear up the problem.—K.K., Skokie, Ill.

This has a very familiar ring to it. Check the 50-μF electrolytic capacitor

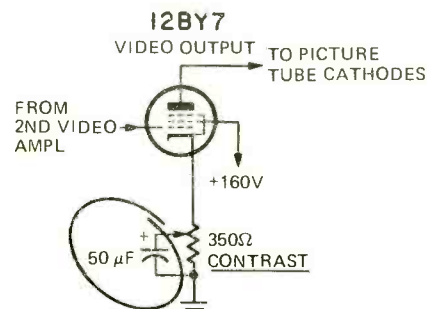

**ELECTROLYTIC BYPASS CAPACITOR** may be cause of washed-out pix. It's probably open.

on the cathode of the 12BY7 video output tube. Note that the contrast control does *not* vary the cathode resistance, but only the position of this capacitor on that resistance. So, it varies the amount of degenerative feedback from the cathode circuit. If the capacitor is open, you'll have maximum feedback at all times, and symptoms exactly like those you describe. See the illustration for a partial circuit.

### BURNT CATHODE RESISTOR

*I'm just getting started in electronics. I found a little radio, with the cathode resistor of the audio output tube*

*burned up. The tube was good. Why did this resistor burn?—K.P., Beaver Dams, N.Y.*

Because there was too much current drawn through it. That sounds a little elementary, but it is true. So if the tube is good, there is only one thing that could cause it to draw so much current. Its grid must be very highly positive. Most likely cause of this, a shorted coupling capacitor to the grid from the plate of the preceding stage.

Remember this reaction; you can use it in every kind of electronics work, from little radios all the way up to color TV. R-E

# profits grow

when you use **RCA** service data

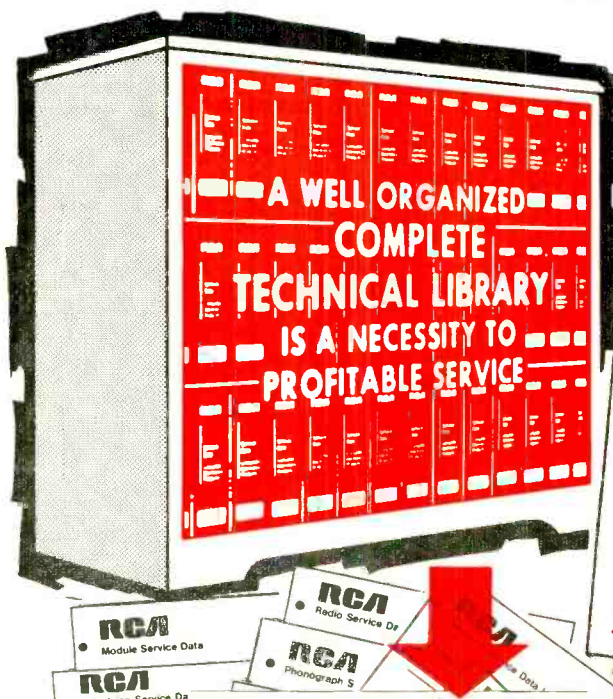

**QUICK REFERENCE AND RELIABLE INFORMATION saves time and makes money**

A SUBSCRIPTION INCLUDES A COMPLETE "FILE" YEAR OF:

- COLOR TELEVISION DATA
- B & W TELEVISION DATA
- RADIO DATA
- PHONOGRAPH DATA
- TAPE RECORDER DATA
- SERVICE TIPS
- PARTS TIPS
- PERIODICAL ISSUES OF "PLAIN TALK"
- "GOLDENROD" BULLETINS
- SERVICE DATA INDEX

**DON'T DELAY! SUBSCRIBE TODAY!**

Please acknowledge my request for a Service Data Subscription:

- "File-1973" Service Data including 3 binders \$25.45
- "File-1973" Service Data subscription \$16.00
- (Binders available separately—\$3.15 each) Number desired \_\_\_\_\_
- Previous Years Data (\$13.50 per set) 72  71  70  69  68  67  66

Amount enclosed: \$ \_\_\_\_\_

NAME \_\_\_\_\_

STREET ADDRESS \_\_\_\_\_

CITY \_\_\_\_\_ STATE \_\_\_\_\_ ZIP CODE \_\_\_\_\_

Your order will be processed promptly upon receipt of your check or money order in the amount indicated above.

SEND TO: **RCA CONSUMER ELECTRONICS** 600 N. Sherman Dr., Indianapolis, Ind. 46201  
ATTN: Technical Publications, 1-450 (Or Contact Your Local Distributor)

NOTE: Prices Subject To Change Without Notice

Circle 15 on reader service card

JULY 1973 • RADIO-ELECTRONICS 67

**BOOLEAN ALGEBRA**

(continued from page 25)

near future, but understanding computer logic will help you when you work in some of the equipment we're using here in the plant. I just finished designing an automated tester which runs a whole series of tests on the gadgets we're building here. It uses computer logic and has about fifty integrated circuit computer logic modules in it."

The little group finished their coffee and prepared to return to work. They were thoughtful, and a little puzzled, about some of the aspects of

this new logic that Phil had been briefing them on. Phil said, "If you can stand a couple more sessions of this stuff, I'll finish up this afternoon and give you a little homework to do. Then tomorrow the man who doesn't have his homework will have the privilege of buying the coffee for the rest of us. If you *all* have it done, I'll buy the coffee and throw in some doughnuts, too."

That afternoon, in the cafeteria, Phil resumed his discussion. "Did you ever hear a little kid who yelled NOT every time his mother wanted him to do something? Well, we have the same thing in computer logic. The

'Not' function means that the switch is exactly opposite to its normal state. For instance, if  $A = 1$ , then  $A\text{-Not} = 0$ . The A-Not is written  $A'$  or  $\bar{A}$ . This rule of NOT also applies to the AND and OR functions. OR-NOT = And, for example. Here are some rules for the NOT functions:  $A + \bar{A} = 1$ . Either A or A equals 1. This simply means that with two switches in parallel and both always opposite in state, there will always be a path through the circuit.

$A\bar{A} = 0$ . This means that the two switches are in series and since they are always opposite, one of 'em will always be open so there will be no current flow.

$A = A$ . This is just like a double negative in speech.

"Here's your homework, fellows. Copy down this schematic, write the equation for it, then apply the rules I've laid down and see what you end up with."



There was a groan from the group as they copied the schematic. George turned to Jim and said, "See what happened? Three days ago we were all happy never having heard of George Boole. Then you open your big mouth and ask a question, and now we're having homework!"

**SOLUTION TO THE PROBLEM**

1. Write the equation:  
 $AB + AB = Y$
  2. Factor out A  
 $A(B + B) = Y$
  3. From a previous rule  
 $B + B = 1$
- so we get  
 $A(1) = Y$
4. From another rule  
 $A1 = A$
- so we end up with  
 $A = Y$
5. The original circuit boils down to just one switch:



**REFERENCES:**

1. Boole, George, An Investigation of the Laws of Thought. (Reprinted from the 1854 edition), Dover Publications, 1780 Broadway, New York City.
2. Whitesitt, J. Eldon, Boolean Algebra and Its Applications, 1962, Addison-Wesley Publishing Company, Reading, Mass.
3. The Burroughs Corporation, Digital Computer Principles, 1962, McGraw-Hill Book Company, Inc., New York City.
4. Blitzer, Richard, Basic Pulse Circuits, 1964, McGraw-Hill Book Company.
5. Carroll, Lewis, Symbolic Logic And The Game of Logic, (Reprinted from the 1896 edition), Dover Publications, Inc.

## TV TUNER SERVICE

**PTS ELECTRONICS, INC.**  
is proud to announce the  
**GRAND OPENING**  
of our new Service Center in

# CLEVELAND, OHIO

now you too...  
...get **Fast 8 hr. Service!**

\$995

1 YEAR GUARANTEE

FREE JOB CARDS

FREE SHIPPING LABELS

Come and see us. PTS Branches are all company owned—No Franchises—we care for our customers. For a TUNER PART or COMPLETE TUNER REBUILT, come to us, we will take care of your tuner problems like no one else can. WE'RE PROFESSIONALS—18 years experience made us what we are!

You owe it to yourself

to try P.T.S. We are the fastest growing, oldest and now the largest tuner service company in the world. Here is what you get:

1. Fastest Service—8 hour—in and out the same day. Overnight transit to one of our plants.
2. Fine Quality! Your customers are satisfied and you are not bothered with returning tuners for rework!
3. Lower Cost! Up to \$5.50 less than other tuners for rework!
4. Friendly, helpful service! We help you do more business—that way we will do more, too. We want your business and we try to deserve it!

Color—Black & White—Transistor—Tubes  
—Varactor—Detent UHF

VHF or UHF..... \$9.95  
UV-Comb..... \$16.95

Major parts, tubes, transistors, shipping  
charged at net cost  
(Dealer net!)

send faulty unit with tubes, shields and all broken parts to:

PTS ELECTRONICS, INC.  
5682 STATE RD.  
CLEVELAND, OHIO 44134  
TEL. 216, 845-4480

or to any of our strategically located Service Centers

for finer, faster,  
...Precision  
Tuner Service

HOME OFFICE—INDIANA  
PTS ELECTRONICS, INC.  
P.O. BOX 272  
BLOOMINGTON, IND. 47401  
TEL. 812, 826-9331

PENNSYLVANIA  
PTS ELECTRONICS, INC.  
P.O. BOX 16824  
PHILADELPHIA, PA. 19142  
TEL. 215, 724-2999

MASSACHUSETTS  
PTS ELECTRONICS, INC.  
P.O. BOX 3189  
SPRINGFIELD, MASS. 01103  
TEL. 413, 734-2737

FLORIDA  
PTS ELECTRONICS, INC.  
P.O. BOX 5081  
JACKSONVILLE, FLA. 32205  
TEL. 904, 385-9952

TEXAS  
PTS ELECTRONICS, INC.  
P.O. BOX 3322  
LONGVIEW, TEX. 75601  
TEL. 214, 753-4334

SOUTHERN CALIFORNIA  
PTS ELECTRONICS, INC.  
P.O. BOX 9794  
SAN DIEGO, CALIF. 92105  
TEL. 714, 780-7070

NORTHERN CALIFORNIA  
PTS ELECTRONICS, INC.  
P.O. BOX 8754  
SACRAMENTO, CALIF. 95841  
TEL. 916, 482-6220

COLORADO  
PTS ELECTRONICS, INC.  
P.O. BOX 9245  
DENVER, COLO. 80204  
TEL. 303, 244-2818

OHIO  
PTS ELECTRONICS, INC.  
5682 STATE RD.  
CLEVELAND, OHIO 44134  
TEL. 216, 845-4480

# equipment report

## RCA Model WV-529A vom

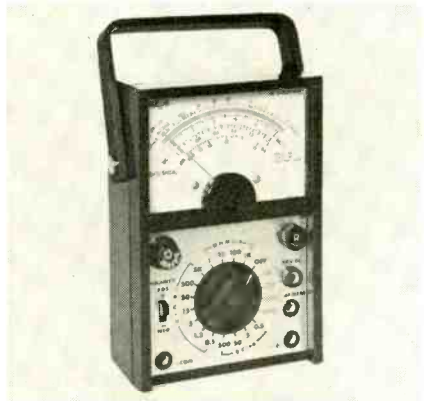

Circle 80 on reader service card

RUGGEDNESS IS A VERY USEFUL THING, especially in test equipment. Although most of us are kind to our precious meters, it's nice to have a rugged little rascal in case of the inevitable accident. RCA has come out with a new vom, called their *Service Special*, the WV-529A. It is specifically designed to take the hard knocks of everyday service work, such as riding around in a tube caddy, and still be useful for any kind of test measurements, bench or outside.

The WV-529A has a taut-band meter suspension, diode protection for the movement against overloads, and a high-impact plastic case. The front panel and meter face are recessed so that they won't be damaged even if it should fall flat on its face. In addition to physical abuse, they've even gone so far as to idiot-proof it with a built-in fuse, in case you insist on reading B+ voltages on the ohms ranges. The fuse holder is placed on the front panel, and they thoughtfully included a spare.

This is a 20,000-ohms-per-volt movement on dc volts, and 10,000-ohms-per-volt on ac. The meter has only two scales, 0 to 5 and 0 to 1.5. All ranges are multiples of these. The scales are color coded for quick reading. Colors on the range switch match the meter scales. The dc voltages run from a useful 0 to 0.5 volts up to a 500-volt scale, and a very useful 5000-volt range. (I'm always wanting to check focus voltage on color sets in the home and this will do it.) A high-voltage probe can be used, for direct reading of high-voltage.

For solid-state testing, the WV-

529A has a handy polarity-reversal switch. It works for both voltage and resistance ranges, making it very useful for quick-checking transistors and diodes, in or out of circuit.

Direct current can be read from 0.5 mA full-scale up to a handy 0 to 500-mA scale, for cathode currents of color TV horizontal output tubes. Ac voltages run from 15 volts full-scale up to 500 volts full-scale.

Resistance ranges go from  $R \times 1$ , which is 20 ohms center-scale, up to  $R \times 1000$ . I checked it out on my pet set of 1% resistors, and it was right on the nose on all ranges. The ohmmeter is powered by two standard penlight cells.

I'm glad to see one feature of some older vom's come back. The WV-529A has an AF MEAS(urement) jack. It is nothing but the old output meter connection; goes to the ac volts ranges through a 0.1- $\mu$ F blocking ca-

pacitor. Very useful for audio signal tracing, which we do a lot of in transistor amplifiers. The ac voltage ranges of the WV-529A will go up to 100 kHz within  $\pm 1$  dB, so you can use it for anything in audio work. A decibel scale is provided for quick checks of signal levels.

All in all, a very useful test instrument and accurate enough for any kind of testing. I compared it against meters costing several times as much, and it came up smiling **R-E**

### COMING NEXT MONTH

Lee De Forest, inventor of the triode, would be celebrating his 100th birthday this August. To commemorate the achievements of this electronics pioneer, **Radio-Electronics** has prepared a special article describing his life, his inventions, his effect on the electronics industry. For those of us too young to remember, the vacuum tube triode was the forerunner of the transistor.

## Now...the most enjoyable do-it-yourself project of your life—A Schober Electronic Organ!

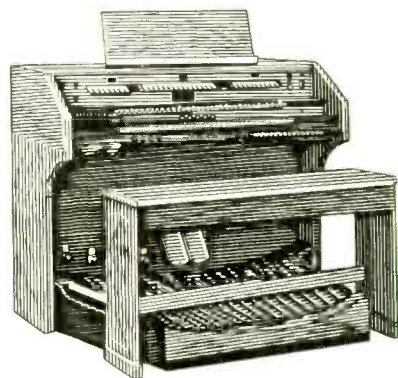

You'll never reap greater reward, more fun and proud accomplishment, more benefit for the whole family, than by assembling your own Schober Electronic Organ.

You need no knowledge of electronics, woodwork or music. Schober's complete kits and crystal-clear instructions show you — whoever you are, whatever your skill (or lack of it) — how to turn the hundreds of quality parts into one of the world's most beautiful, most musical organs, worth up to twice the cost of the kit.

Five superb models with kit prices from \$500 to around \$2,000, each an authentic musical instrument actually superior to most you see in stores, easy for any musically minded adult to learn to play, yet completely satisfying for the accomplished professional. And there are accessories you can add any time after your organ is finished—lifelike big auditorium reverberation, automatic rhythm, presets, chimes, and more.

Join the thousands of Schober Organ builder-owners who live in every state of the Union. Often starting without technical or music skills, they have the time of their lives — first assembling, then learning to play the modern King of Instruments through our superlative instructions and playing courses.

Get the full story FREE by mailing the coupon TODAY for the big Schober color catalog, with all the fascinating details!

The Schober Organ Corp., Dept. RE-116  
43 West 61st Street, New York, N. Y. 10023

- Please send me Schober Organ Catalog.  
 Enclosed please find \$1.00 for 12-inch L.P. record of Schober Organ music.

NAME \_\_\_\_\_  
ADDRESS \_\_\_\_\_  
CITY \_\_\_\_\_ STATE \_\_\_\_\_ ZIP \_\_\_\_\_

Circle 17 on reader service card

# WHAT'S THE BIG IDEA?



## We've Got A Lot Of Big Ideas For You In Our New *Free* Circuit Design Catalog!

Look through it. You'll find everything you need to help you with your circuit design projects.

- The famous SK-10 socket, for solderless circuit design and testing.
- The new DIGI DESIGNER, in kit form or assembled.
- A digital logic course for the experimenter or student.
- The great ELITE breadboarding systems.
- Plug-in socket boards.
- Low cost power supplies; pulse generators.
- Breadboarding pins; semiconductor components.
- Plus . . . much more!

**Best of all . . . it's FREE!**

Write today, and let us help put your big ideas to work!



**E & L INSTRUMENTS, INC.**  
61 First Street  
Derby, Connecticut 06418

# next month

AUGUST 1973

There's more than just TV sets, radio receivers and hi-fi gear that need repairing. In this issue **Radio-Electronics** looks at three new areas—calculators, microwave ovens, and telephone answering machines.

- **Calculators, How To Keep Them Working**  
The basic theory of how electronic calculators work, how to tell what's wrong when they don't work, and how to fix them.
- **Radar Ovens, Simple Electronic Circuits**  
The fundamentals of radar cookery and the special equipment needed to keep them cooking, along with service tips and techniques.
- **Telephone Answering Machines**  
See how these devices differ from conventional tape recorders and get to understand the fundamentals of their operation. Repair techniques are quite similar to those for ordinary tape machines.
- **WWVB Receiver Keeps Superclock On Time**  
Don Lancaster shows how to build a WWVB receiver that keeps Superclock (July 1972) on time. Add it to his time-zone-switched digital clock and you'll have one of the most precise timepieces ever built.
- **Phase-Lock-Loop For FM**  
Len Feldman, R-E's High Fidelity Contributing Editor shows how these circuits work and why they are so popular.

## PLUS

Lee De Forest—Father Of Radio  
Lou Garner's State-Of-Solid-State  
R-E's Replacement Transistor Guide  
Jack Darr's Service Clinic



# new books

**THE RADIO AMATEURS' V.H.F. MANUAL, Third Edition, by Edward P. Tilton and Douglas A. Blakeslee. The American Radio Relay League, Newington, Conn. 06111. 6 1/2 x 9 1/2 in. 352 pp. Softcover, \$2.50 in U.S. and possessions, \$3.00 elsewhere.**

Like its two earlier predecessors, this edition is largely the work of QST's VHF Editor Ed Tilton, W1HDQ, with three chapters on FM by Doug Blakeslee, QST's Technical Editor. Almost completely rewritten since the 1968 edition, the book is chock full of new material on SSB, solid-state circuits and components, converters, transmitters, receivers, antennas, test equipment and techniques and can be considered as the amateurs' bible on "the world above 50 MHz."

A must for hams planning to operate on 6 meters and above, and recommended reading for TV, FM and vhf/uhf broadcast engineers, and technicians servicing commercial radio equipment.—RFS

**101 QUESTIONS & ANSWERS ABOUT AM, FM, AND SSB, by Leo G. Sands. Howard W. Sams & Co., Inc., 4300 W. 62nd St., Indianapolis, IN 46268. 5 1/2 x 8 1/2 inches, soft cover, 96 pages. \$3.95.**

Divided into three parts, this book can serve as a text for the radio enthusiast or service technician who has paid little attention to the theory underlying radio transmission and reception, and to the amateur or engineer who can use a refresher, or possibly a little closer acquaintance with one of the three techniques.

The orientation is toward two-way radio (the author has probably written more books on mobile two-way communication than any other person in the country) but broadcast techniques are covered. There is a short glossary of abbreviations and special terms used in the three forms of communication.—FS

**SOLID STATE SERVICING by RCA Institutes. RCA Distributor Products, Harrison, N.J. 07029. 352 pp. \$3.95.**

The widespread use of solid-state devices in home entertainment and industrial equipment has provided an opportunity and challenge to the service technician—the opportunity to expand his knowledge and the challenge of an ever expanding technology. This book contains information on servicing the solid state circuits used in AM and FM radio and in color and black and white television as well as those used in the amplifiers and control circuits of high-fidelity equipment and tape recorders. Also included are chapters covering the principles of solid state devices.

**HANDBOOK OF LOGIC CIRCUITS by John D. Lenk. Reston Publishing Co., Inc., P.O. Box 547, Reston, Va. 22090. pp. \$15.00.**

This text presents more than 200 working logic circuits. These time-tested circuit applications can be put to immediate use by the designer or can be used by the student as a basis for laboratory experiments in logic functions and design. The first chapter is an introduction to logic circuits, logic symbols and basic principles of logic equations and their corresponding functions. The remaining chapters cover subjects such as basic logic networks, decoders, encoders, function generators, parity networks, comparators, data distributors and selectors, adders, subtractors and miscellaneous networks. An appendix provides useful logic tables and procedures for testing logic circuits.

**PICTORIAL GUIDE TO TAPE RECORDER REPAIRS by Forest H. Bell. Tab Books, Monterey & Pinola Sts., Blue Ridge Summit, Pa. 256 pp. \$7.95—hardbound, \$4.95—paperback.**

320 photographs and step-by-step text show how to disassemble, clean, troubleshoot and repair mechanisms and electronics in all types of tape recorders. Included are home tape decks, reel-to-reel stereo decks, mono and stereo cassette machines, 4-channel machines, push-to-talk open-reel dictation recorders, the Dolby circuits, small portable cassettes, mono, stereo and 8-track auto players, tape splicing instructions and degaussing. With this aid of volume, any technician should be able to repair most tape machines.

**DICTIONARY OF TELECOMMUNICATIONS by R. A. Bones. Philosophical Library, 15 E. 40th St., New York, N.Y. 10016. 200 pp. \$15.00.**

Economic growth throughout the world is closely linked with the development and growth of telecommunications systems. Modern industry demands ever-improving facilities for its executives to be able to speak with each other from opposite sides of the globe. As a result, a new language has developed. This dictionary is an attempt to document that language. The wide range of definitions including many reproduced from or based on British Standards recommendations is supplemented by appendices including units and abbreviations, wavelengths and frequency bands and signal reporting codes. R-E

# What! You still haven't tried the security field?

**PLC Electronics Security Systems are prepackaged for the Electronics man and can be installed by the Electronics man with no special training or experience needed!**

Send for your free Alarm Security System Catalog today!

Equipment available from your local Electronics Distributor.



Electronics, Inc.

39-50 Crescent St./Long Island City, N.Y. 11101

Circle 19 on reader service card

## Accuracy like a VTVM... Convenience like a VOM...

**NEW BATTERY-OPERATED FET SOLID-STATE VOLT-OHMMETER #116**

Easy-to-build KIT

**\$30.<sup>90</sup> =116K**

Factory-Wired & Tested

**\$42.<sup>90</sup> =116W**

Now you can get all the benefits of a VTVM (laboratory accuracy, stability and wide range) but with its drawbacks gone: no plugging into an AC outlet, no waiting for warm-up, no bulkiness. New Field Effect Transistor (FET) design makes possible low loading, instant-on battery operation and small size. Excellent for both bench and field work.

Compare these valuable features:

- High impedance low loading: 11 megohms input or DC, 1 megohm on AC
- 500-times more sensitive than a standard 20,000 ohms-per-volt VOM
- Wide-range versatility: 4 P-P AC voltage ranges: 0-3.3, 33, 330, 1200V; 4 RMS AC voltage ranges: 0-1.2, 12, 120, 1200V; 4 DC voltage ranges: 0-1.2, 12, 120, 1200V; 4 Resistance ranges: 0-1k, 0-100k, 0-10 meg., 0-1000 meg.; 4dB ranges: -24 to +56dB.

Sensitive easy-to-read 4 1/2" 200 micro-amp meter. Zero center position available. Comprises FET transistor, 4 silicon transistors, 2 diodes. Meter and transistors protected against burnout. Etched panel for durability. High-impact bakelite case with handle useable as instrument stand. Kit has simplified step-by-step assembly instructions. Both kit and factory-wired versions shipped complete with batteries and test leads. 5 1/4" H x 6 3/4" W x 2 7/8" D. 3 lbs.

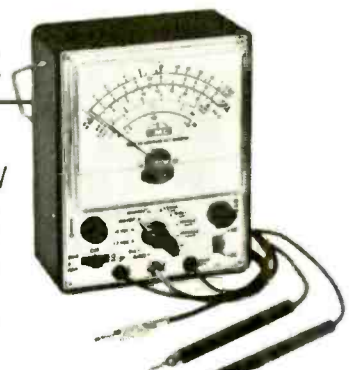

Send FREE catalog of complete EMC line and name of nearest distributor. RE-7

Name \_\_\_\_\_

Address \_\_\_\_\_

City \_\_\_\_\_

State \_\_\_\_\_ Zip \_\_\_\_\_

**EMC**

ELECTRONIC MEASUREMENTS CORP.  
625 Broadway, New York, N.Y. 10012

# learn by doing!

Perform more than 200 exciting experiments with CIE's fascinating **ELECTRONICS LABORATORY PROGRAM!**

Put theory... into practice

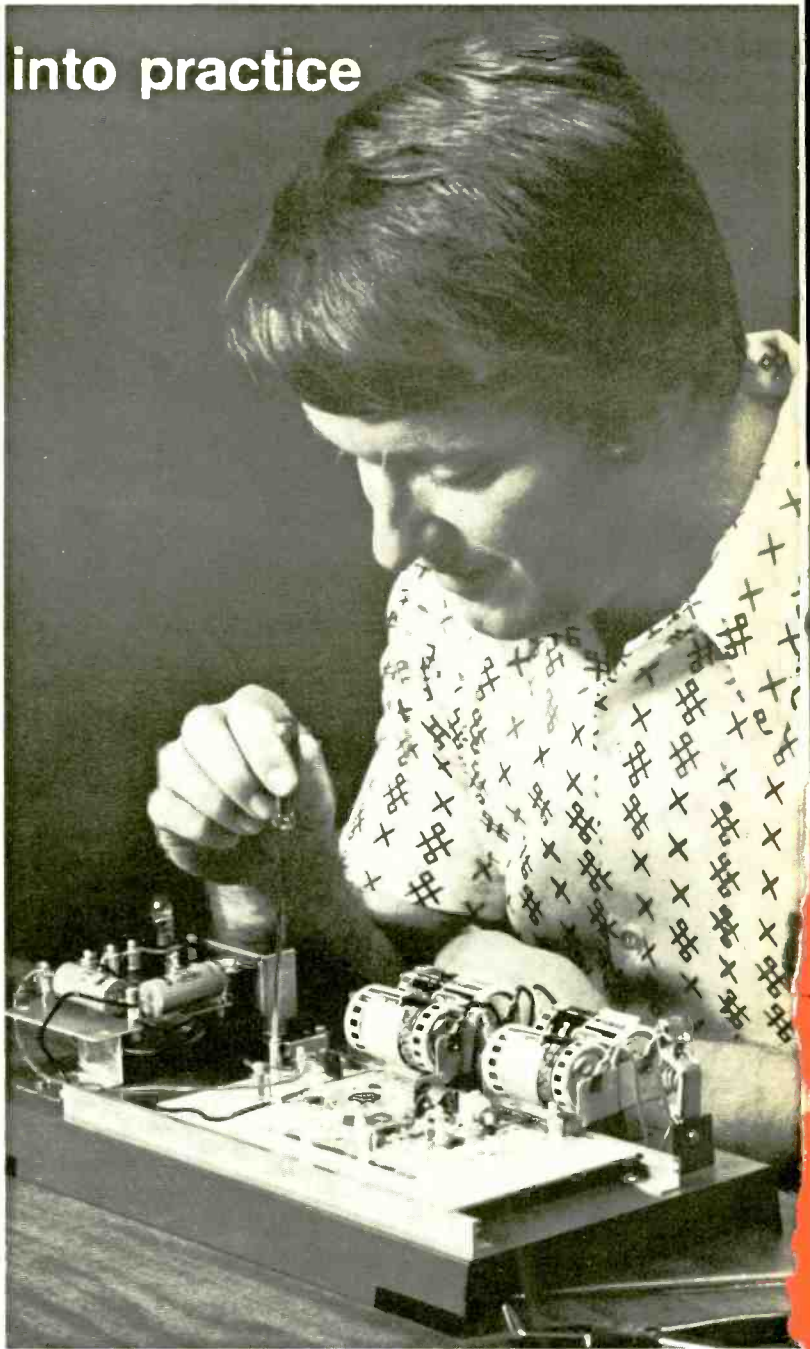

# You get your own 161-piece electronics laboratory... with authentic electronic components used by industry!

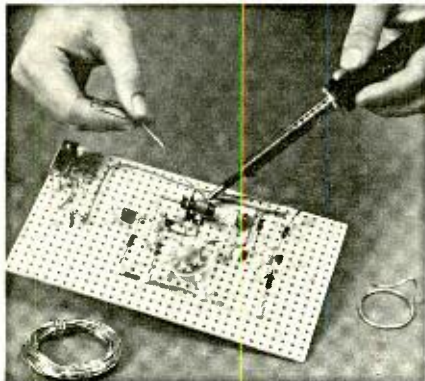

You learn how to construct circuits and connect them with a soldering iron, which is part of your CIE laboratory equipment. This "hands on" experience is extremely valuable in applying what you learn.

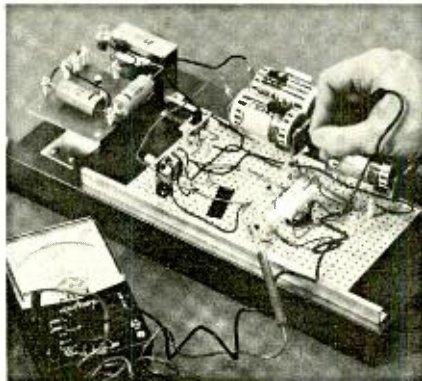

Testing and troubleshooting are an important part of your learning experience. Included in your laboratory is a precision "multimeter" to diagnose electrical and electronic troubles quickly and accurately.

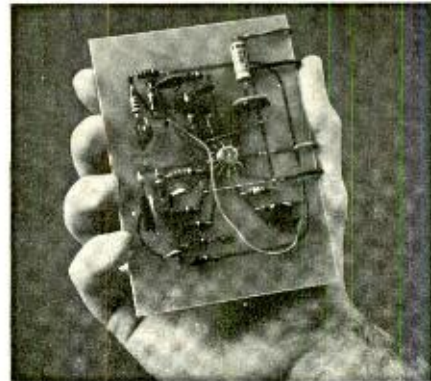

Modern space-age components like this IC (integrated circuit) are professional quality and can be used again and again in many of your projects. Lesson by lesson, piece by piece your knowledge grows!

## Prepare now for a high income career in Electronics...the Science of the Seventies.

Electronic miracles are changing today's world with breathtaking speed.

And with this growth in electronics technology has come a brand new need... a demand for thousands of electronics technicians, trained in theory and practice to build the products, operate them and service them during the Seventies.

Don't just wait for something to "happen" in your present job. Get ready now for a career you'll really enjoy with a good income and plenty of opportunity for advancement.

### Experience with experiments is your best teacher

"Hands on" experience helps to reinforce basic theory. When you learn by doing, you discover the "how" as well as the "why." You'll find out for yourself the right way as well as the wrong way to use electronic components. How to construct your own circuits, to discover trouble spots and learn how to fix them. And with CIE's special Auto-Programmed® Lessons, you learn faster and easier than you'd believe possible.

CIE's fascinating course, Electronics Technology with Laboratory, teaches you Electronics by making it work before your eyes. And you do it yourself, with your own hands.

### Importance of FCC License and our Money-Back Warranty

Many important jobs require an FCC License and you must pass a Government licensing exam to get one.

But, a recent survey of 787 CIE graduates reveals that better than 9 out of 10 CIE grads passed the FCC License exam.

That's why we can offer this famous Money-Back Warranty: when

you complete our Laboratory Course, which provides FCC License preparation, you'll be able to pass your FCC exam or be entitled to a full refund of all tuition paid. This warranty is valid during the completion time allowed for your course.

You get your FCC License — or your money back!

### You'll have high paying job opportunities

Electronics is still young and growing. In nearly every one of the new exciting fields of the Seventies you find electronics skills and knowledge are in demand. Computers and data processing. Air traffic control. Medical technology. Pollution control. Broadcasting and communications. With a CIE Diploma and an FCC License you can choose the career field you want... work for a big corporation, a small company or even go into business for yourself.

Here's how two outstanding CIE students carved out new careers: After his CIE training, Edward J. Dulaney, President of D & A Manu-

facturing, Inc., Scottsbluff, Nebraska, moved from TV repairman to lab technician to radio station chief engineer to manufacturer of electronic equipment with annual sales of more than \$500,000. Ed Dulaney says, "While studying with CIE, I learned the electronics theories that made my present business possible."

Marvin Hutchens, Woodbridge, Virginia, says: "I was surprised at the relevancy of the CIE course to actual working conditions. I'm now servicing two-way radio systems in the Greater Washington area. My earnings have increased \$3,000. I bought a new home for my family and I feel more financially secure than ever before."

### Send now for 2 FREE BOOKS

Mail the reply card or coupon for our school catalog *plus* a special book on how to get your FCC License. For your convenience, we will try to have a representative call. If coupon is missing, write: Cleveland Institute of Electronics, Inc., 1776 E. 17th St., Cleveland, Ohio 44114. Do it now!



Approved  
under  
G.I. Bill

All CIE career courses are approved for educational benefits under the G.I. Bill. If you are a Veteran or in service now, check box for G.I. Bill information.

**CIE** Cleveland Institute of Electronics, Inc.  
1776 East 17th Street, Cleveland, Ohio 44114  
Accredited Member National Home Study Council

Please send me your two FREE books:

1. Your illustrated school catalog, "Succeed in Electronics."
2. Your book, "How to Get a Commercial FCC License."

I am especially interested in:  Electronics Technology with Laboratory  
 Electronics Technology  Industrial Electronics  
 Electronic Communications  First Class FCC License  
 Broadcast Engineering  Electronics Engineering

Name \_\_\_\_\_ Age \_\_\_\_\_  
(PLEASE PRINT)

Address \_\_\_\_\_

City \_\_\_\_\_ State \_\_\_\_\_ Zip \_\_\_\_\_

Veterans and Servicemen: Check here for G.I. Bill information.

RE-20

Circle 20 on reader service card

# Profits grow faster with SK 3016.

It's all you need to put top-of-the line quality in nearly 2,600 replacements. With it, you can offer more on-the-spot service and build better business efficiency all down the line. It's just one of RCA's 156 SK devices that can replace over 51,000 different foreign and domestic types.

See your RCA Distributor today. He'll give you the full story on SKs and your copy of the new RCA SK Replacement Guide SPG-202N. RCA Electronic Components Harrison, N.J. 07029

**RCA** Electronic Components



# LED panel lights

A fast-growing replacement for the incandescent panel lamp. Types with red and/or green light are new innovations.

by WILLIAM D. KRAENGEL, JR.

IN THE QUEST TO IMPROVE EXISTING designs, new products are developed that have many advantages over their predecessors. The Light Emitting Diode (LED) is just such a development. The advantages of LED's over other types of indicators, are well known. However, of particular interest to the technician/experimenter are the LED's low power requirement and speed of response in addition to its long life, ruggedness, small size and, perhaps most important of all, economy. The economy of using a LED as a panel light becomes obvious when you compare the cost of a typical

LED (less than \$0.50 in small quantities) with that of a low-power indicator lamp and lamp assembly and then add the savings in labor costs obtained by using LED's.

But what of these savings? They can only be realized if the already existing LED packages are readily adaptable for panel light use. Fortunately, with a few special techniques that are within the scope of the smallest shops—drilling a hole in the panel—some LED packages are ideal for this use. In fact, by reading the manufacturer's literature, you get the distinct impression that this is indeed a use that they are advocating. A few

TABLE OF LED'S FOR PANEL-LIGHT APPLICATIONS

MANUFACTURER	PART NUMBER	LENS TYPE	LIGHT (SOURCE) EFFECT
Texas Instruments	TIL209	Red Diffused	Soft
	TIL210	Red Diffused	Soft
General Electric	SSL-12	Red Diffused	Soft
	SSL-212		
	SSL-22		
	SSL-22L	Red Diffused	Soft
Monsanto	MV5010	Clear	Point
	MV5011	Diffused	Soft
	MV5012	Red	Point
	MV5013	Red Diffused	Soft
	MV5020	Clear	Point
	MV5021	Diffused	Soft
	MV5022	Red	Point
	MV5023	Red Diffused	Soft
	MV5024	Red Diffused	Flooded
	MV5025	Red Diffused	Fully Flooded
	MV5030	Clear	Point
	MV5033	Red Diffused	Soft
Monsanto	MV5080	Clear	Point
	MV5082	Red	Point
Dialco	521-9165	Red Diffused	Soft
	521-9166	Diffused	Soft

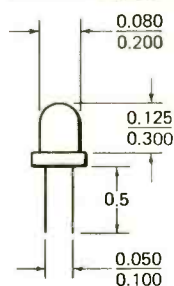

ALL DIMENSIONS ARE IN INCHES AND ARE TYPICAL ONLY. CONSULT INDIVIDUAL DATA SHEETS FOR FULL DETAILS.

FIG. 1—DIMENSIONS OF AN LED of the type most readily adapted for panel mounting.

manufacturers even provide some hardware for this purpose but generally it is available only on special order.

This article presents a method of mounting LED's that eliminates any need for special hardware. All that is needed is the LED itself. The Table lists some of the more popular LED's of the package design shown in Fig. 1, that are especially well suited for panel light use. Surplus outfits are selling some of these very same LED's

except, for some strange reason, under their own numbers. A filled lens on the LED is recommended as this provides a diffused source that gives the appearance of the LED being bigger and brighter than it actually is. A clear LED is often only adequately visible when viewed "head-on" and then with only a small area of actual illumination.

The LED leads provide all the vertical support that is necessary. They are adequately rigid for this purpose. Fig. 2 shows how to mount the LED

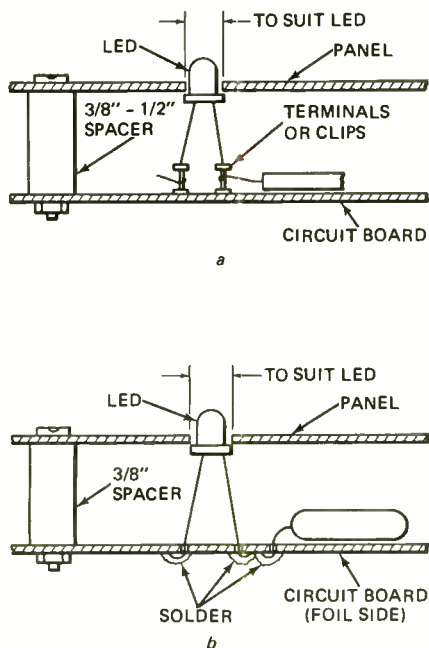

FIG. 2—HOW LED'S CAN BE MOUNTED as panel indicators. The sub-panel may be perforated board (a) or standard PC board (b).

on both perf board and a printed-circuit board. The clearance hole in the panel provides the necessary horizontal alignment. If the clearance hole is about 0.004" larger in diameter than the LED, it will provide critical alignment and close fit while still allowing easy insertion.

Now that you are all set to start sticking LED's all over the place—hold up a minute! Everyone is familiar with the principles of LED operation—it seems that there is an article about opto-electronics in nearly every technical magazine that one picks up—but just keep a few simple precautions in mind. LED's are diodes, therefore, it is reasonable to expect that they have forward and reverse voltage and current characteristics the same as any conventional diode. They do and this means that they are applied in a similar manner. Polarity is identified by markings on the LED as indicated on the data sheets and *must be observed in the normal fashion*. The low reverse voltage rating of the typical LED (2-3 volts) might cause problems in the presence of high reverse voltages, but

a conventional diode placed in series with the LED for reverse voltage blocking, as in the ac circuit of Fig. 3, solves any potential problems handily. LED's may also be used in series or parallel for voltage or current addition.

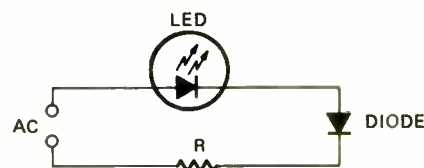

FIG. 3—THE LED IS A DIODE with a very low reverse voltage rating. A series diode protects against high reverse voltage.

If the LED leads have to be bent, do not bend them any closer than 1/16" from the LED base. These LED packages are plastic and have a nasty habit of splitting in two if they are overstressed. As is true when soldering any solid-state device, when soldering avoid excessive heating of the LED. Use a heatsink between the connection and the LED while soldering.

Just to get you started on your way, Fig. 4 shows two of the more

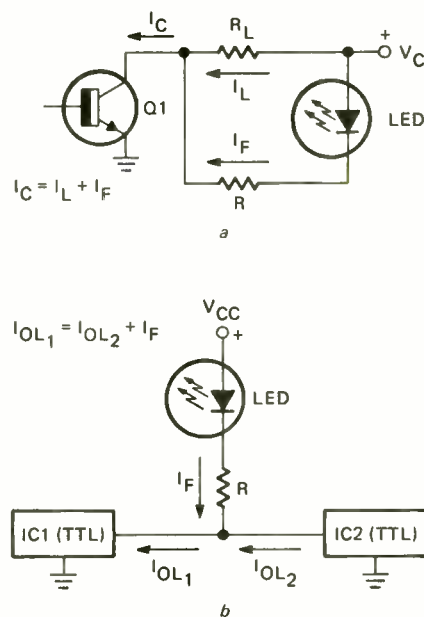

FIG. 4—THE STATE OF THE TRANSISTOR is shown by the LED in circuit (a) while circuit (b) indicates logic state in-circuit.

common in-circuit applications where the LED's low power requirement and response speed are used to advantage. Of course no explanation is necessary regarding the use of LED's as power indicators other than to remind one not to forget the current limiting resistor. Otherwise—Poof!

So go to it! There are an almost unlimited number of in-circuit uses for LED's now that panel indication is feasible. The ultimate usage of the LED panel light is limited only by the ingenuity of the user. R-E

## Keep inventories small with SK 3004.

It's the only solid-state device you need to make over 4,000 different replacements. And it's just one part of RCA's compact SK line of 156 devices that can replace over 51,000 foreign and domestic types. SK is the way to go to cut inventory to the bone and still have the replacement you need when you need it.

Ask your RCA Distributor about SK, The Solid State System. And get your copy of the new RCA SK Replacement Guide SPG-202N.

RCA Electronic Components  
Harrison, N.J. 07029

**RCA** Electronic Components



# new products

More information on new products is available from the manufacturers of items identified by a Reader Service number. Use the Reader Service Card inside the back cover.

**TRANSISTOR-DIODE TESTER, WT2** works both in-circuit and out-of-circuit. Four simple-to-operate switches allow rapid analysis of a transistor or diode. The unit does not measure gain or leakage characteristics; instead it tests for leakage, emitter-to-base and base-to-col-

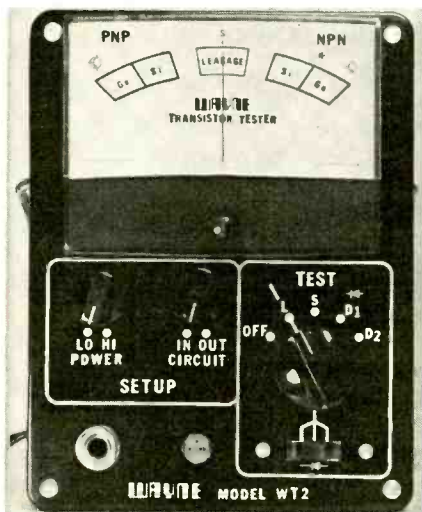

lector diode characteristics, emitter-to-collector shorts. Determines pnp or npn and identifies the type of semiconductor (silicon or germanium). Three in-circuit finger probes for one-hand probing or three clip leads are included.

AC powered, 3 lbs., 6 $\frac{3}{4}$ " x 5 $\frac{1}{4}$ " x 3". \$79.95.—Wayne Electronics, 5412 Nordling Street, Houston, Texas 77022.

Circle 31 on reader service card

**MAGNETIC PHONOGRAPH CARTRIDGES** use a patented magnetic circuit called Variable Magnetic Shunt which provides both extra linearity and



lower mass than conventional arrangements. Feature high compliance, extended frequency response and wide spectrum tracking ability at low tracking

forces.

\$25 to \$80 depending on stylus type and compliance. Include user-replaceable styli and have output to match all conventional magnetic phono inputs.—Ortofon, 9 East 38th Street, New York, N.Y. 10016.

Circle 32 on reader service card

**TINITOOL KIT No. 030** features three different miniature tools: No. 031 (straight scribe), No. 032 (triangular scraper) and No. 033 (bent prober). All are made from 1/32" diameter oil-hard-

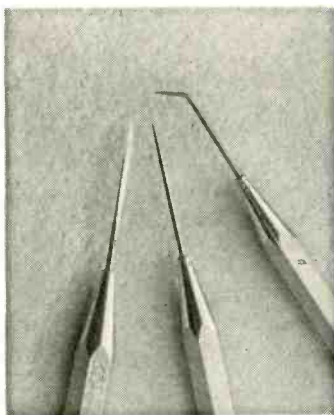

ened tool steel, nickel plated. Handles are 4" long non-rolling hexagonal aluminum. Tool tips are dipped in plastic for protection. Kit is housed in a plastic container. \$2.85.—Minitool, 15070 Dickens Avenue, San Jose, Calif. 95124.

Circle 33 on reader service card

**ELECTRONIC INSTRUMENT PROCESSOR, Synthespin MK-II** produces a wide range of special effects including electronic rotating speaker, phaser/wah and

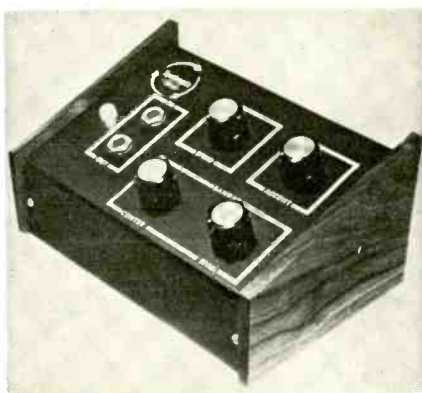

pseudo-reverb. This updated version features integrated circuit construction, wide rotating speed range (.2 to 15 cycles per second) and rear panel voltage control programming jacks. May be used either in automatic mode or manually controlled with optional foot pedals.

Wired and tested model 1702A is \$49.95; kit model 1702K is \$24.95.—PAIA Electronics Inc., 6700 North Classen Blvd., Oklahoma City, Okla. 73116.

Circle 34 on reader service card

**POCKET MULTITESTER model 51-150.** Rotary switch for range selection. Unit is 1,000 ohms/volt, volt-ohms-milliampmeter. Ranges: ac, 15V, 150V, 1000V; dc, 15V, 150V; dc, 1 mA., 150 mA. Resistance: 100,000 ohms, 1.5 ohm.



Accuracy is +3% of fullscale on dc ranges, +4% of fullscale on ac ranges, +10% of ohms. 2-2/8" x 3-9/16" x 1-3/16", \$41.55.—Weltron Company, 305 South Dillard Street, Durham, N.C. 27702.

Circle 35 on reader service card

**DOLBY TAPE ADAPTER, model DBA-9** can Dolbyize cassette decks and reel-to-reel tape units and when used with any

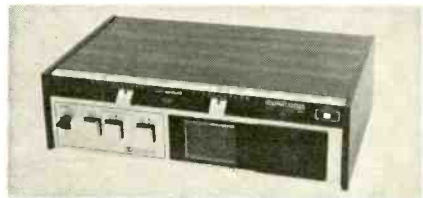

FM tuner or receiver, can decode Dolby FM broadcasts. Unit is patched between tape deck and amplifier and/or between FM tuner section and amplifier.

When switched into a stereo system, the unit provides 8-dB noise and hiss reduction at 2000 Hz and a 10-dB reduction from 5000 to 15,000 Hz. Frequency response is 20-15,000 kHz  $\pm$  0.5 dB. 10 $\frac{3}{4}$ "W x 3"H x 7 $\frac{1}{2}$ "D; 5 $\frac{3}{4}$  lbs. Includes cabinet, two stereo patchcords, plus cassette and 3" reel Dolby alignment tapes. \$99.85.—**Concord Division, Benjamin Electronic Sound Company**, 40 Smith Street, Farmingdale, N.Y. 11735.

Circle 36 on reader service card

**NOISE AND FREQUENCY TESTER**, model NF-1. Dual-purpose instrument checks the relative noise of transistors and Zeners and indicates the relative frequency response of transistors and signal diodes. Enables television technician to select replacement transistors



with the proper frequency response, particularly for use in the critical front-end high-frequency circuits.

Operator selects desired mode of operation, depresses a test button and reads the characteristic being tested on a large color coded meter. An attenuator switch adjusts the noise level to the proper null point on the meter in order to get a noise reading. 8" x 6" x 4 $\frac{1}{2}$ "; 4 lbs.; \$149.95.—**Jud Williams Company Inc.**, P.O. Box 671, Winter Haven, Fla. 33880.

Circle 37 on reader service card

**SOLID-STATE RECTIFIERS** are direct plug-in replacements for electron tubes in certain television applications. Types ECG508/R-3A3, ECG509/R-3AT2 and ECG510/R-3DB3 are high-voltage recti-

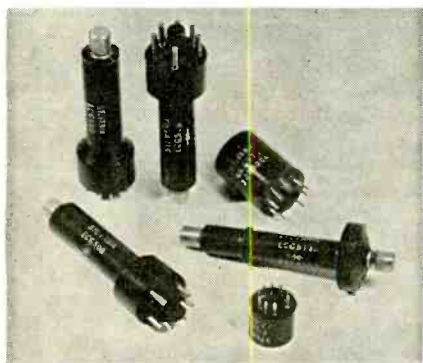

fiers; ECG511/R-2AV2 is a focus rectifier; ECG512/R-DW4 is a damper diode and ECG513 is a 45-kV stick rectifier used in high-voltage applications. Packaged individually with a data sheet that gives mechanical and electrical ratings and a list of tube types they replace. They replace almost 80,000 domestic

and foreign types used in commercial and industrial applications.—**GTE Sylvania Inc.**, 730 Third Avenue, New York, N.Y. 10017.

Circle 38 on reader service card

**CONNECTOR ADAPTERS** interconnect any combination of cables and connectors that have BNC, phono (RCA

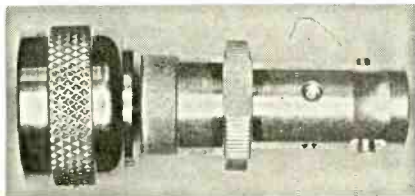

type), microphone (Amphenol  $\frac{1}{4}$ -27 type) or type F (MATV/CATV type) terminations. For use in test equipment, audio, video and rf applications; \$4.95.—**Adapters Unlimited**, P.O. Box 48822, Los Angeles, Calif. 90048.

Circle 39 on reader service card

**CAR STEREO RADIO AND 8-TRACK TAPE PLAYER**, model C976 features five

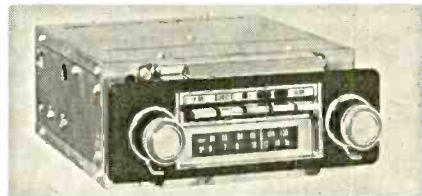

# CHANNELLOCK

Gives You More In Hand Tools Including

## STANDARD "SPECIALS"

(at standard prices)

Every one of these special purpose tools is a standard item in the CHANNELLOCK line, at standard price.

Why show these "specials"? To tell you that you can get CHANNELLOCK quality in a wide range of both standard and special purpose pliers.

GET THE WHOLE STORY in our three-color catalog. Yours for the asking.



**ELECTRICIANS' WIRING PLIER.** Patented notches strip insulation from 14 and 12 gauge wire slick as a whistle.



**WIREMASTER PLIER.** High leverage design provides 40% more cutting power than standard design wire cutting pliers.



**CURVED LONG NOSE PLIER.** Goes 'round the corner to get to work.



**PLASTIC CUTTING DIAGONAL.** Flush-trims molded plastic sprues clean, fast.



**SHORT NOSE SHEARING PLIER.** High leverage design for easy cutting of channel iron flanges.



**CURVED DIAGONAL CUTTER.** Jim-dandy for pulling cotter pins.

TOOLS BY  
**CHAN NEL LOCK**  
MEADVILLE, PA. 16335

Circle 21 on reader service card

# BIRTHDAY SALE

## FAMOUS BRANDS

25—2.5 Amp. 1000 Piv Rect. ....	\$3.95
10—DD-04 Dual Diodes .....	\$2.98
10—DD-05-Dual Diodes .....	\$2.98
1 Amp. 1000 PIB Top Hats .....	20 for \$3.49
3 Amp. 1000 PIV .....	20 for \$3.95
1N34A Diodes .....	25 for \$2.00
6500 PPIV Focus Rectifiers .....	4 for \$2.00
13.5 KV Focus Rectifiers .....	5 for \$3.00
18.5KV Focus Rect. ....	3 for \$2.49
RCA Color Crystals 3.58 MC .....	2 for \$2.49
2—Damper Diodes RCA 135320 .....	\$2.98
Zenith Voltage Tripler .....	\$4.95
Zenith Color Chip 212-45 .....	\$3.95 Ea.

## COLOR YOKES—COLOR YOKES

SILVERTONE—80-56-4G .....	\$5.95 Ea.
MOTOROLA QUASAR-24D68592BO1	\$5.95 Ea.
Equiv. DY95AC-Y109-Universal ...	\$6.95 Ea.
MAGNAVOX 361340-Equiv. Y-133 ..	\$5.95 Ea.
MAGNAVOX X361380-Equiv. Y-134	\$5.95 Ea.
MAGNAVOX 361395-Equiv. Y-135 ..	\$5.95 Ea.
Circuit Breakers-1.25 Amp .....	10 for \$1.00
10 AC Interlock Polarized .....	\$1.00
AC Cube Taps—3 Outlets .....	5 for \$1.00
HV Anode Leads B/W .....	10 for \$1.00
CRT Harness Short Leads Color ...	5 for \$1.00
100 Mica Cond. Assorted .....	\$1.00
100 By-Pass Cond. Assorted .....	\$4.95
.01 Mfd.—1KV Spark Gap .....	20 for \$2.00
25 Assorted Disc Cond. ....	\$1.39
100 Mfd.—150 Volts Axial .....	12 for \$1.98
50 Assorted Fuses (5 Box) .....	\$1.98
10 Align. Tools Asst'd. ....	\$1.98
20 Asst'd Mallory Controls .....	\$2.00
5—1 Meg. On/Off Sw. ....	\$1.00
Wire Wound Resistors Asst'd ....	20 for \$1.39

## TUNERS—NEW—WITH TUBES

Standard Coil Parallel 6GJ7-6HA5 ...	\$6.95
Sarkes—Tarzian Parallel 6GJ7-6HA5 ..	\$6.50
Sylvania Transistor—54-29331-3 .....	\$6.95
Silvertone Combo-UHF-VHF-Par. ....	\$7.95
Silvertone Combo-UHF-VHF-Series ....	\$7.95
Silvertone Series .....	\$4.95
Philco Series 76-13983-5GJ7-3HA5 .....	\$4.50
Philco Series 7613579-6—5GJ7-3HAS ...	\$4.50
Gen. Elect. Series 5GJ7-3HA5 .....	\$5.95
Sylvania Series-54-27887-1—5GJ7-3HQ5 ..	\$5.95
Sylvania Series-54-15967-35GJ7-3GK5 ...	\$5.95

## RAYTHEON TUBES

6BA11 .....	5 for \$4.50
12GE5 .....	5 for \$4.50

MINIMUM ORDER \$15.00

SEND FOR FREE CATALOG

TUBES UP TO 80% OFF

SEND CHECK OR  
MONEY ORDER

TV TECH SPECIALS

P.O. BOX 603

Kings Park, L.I., New York 11754

Circle 22 on reader service card

80 RADIO-ELECTRONICS • JULY 1973

push button tuning of which four can be set for AM or FM. 8 watts output per channel; AM, FM stereo indicator lights; local/distant switch, front-to-rear balance control, left to right balance control and automatic or manual track switching.

AM sensitivity is less than  $15\mu\text{V}$  at 20 dB S/N. FM sensitivity is less than  $5\mu\text{V}$  at 30 dB S/N. FM stereo separation less than 20 dB. \$299.95.—**Audlovox Corporation**, 150 Marcus Blvd., Hauppauge, N.Y. 11787.

Circle 40 on reader service card

**WORD PROCESSING SYSTEM, series 180** uses an endless loop of magnetic tape sealed in a Thought Processing Tank to instantly take down and transmit dictation. It is conveyed by an office telephone either inside the office or externally.

Storage and transcription of recorded material is fully automatic; no

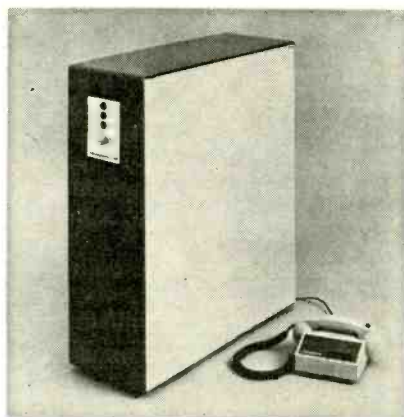

recording medium is ever touched. Transcription begins 12 seconds after a recording is started so that the word-processing operator can be transcribing as dictation is given. Work flows into tank and out in one continuous motion. Provides three hours of recording time—equal to 12 hours of transcription time.—**Dictaphone Corp.**, 120 Old Post Road, Rye, N.Y. 10580.

Circle 41 on reader service card

**CAR SPEAKER SETS, model A2000 series** consists of a pair of Poly-Planar 10-watt rms, high-compliance  $5\frac{1}{4}$ " speakers that require only  $\frac{7}{8}$ " mounting depth. They have custom snap-on grilles in black soft padded vinyl or chrome.

Frequency response is 55 Hz to 20



kHz, impedance is 8 ohms. Flat speaker design fits anywhere, is high temperature and fully weatherproof and ideal for

boats, autos, trailers and aircraft; \$19.95 pair.—**Magltran Company**, 311 East Park Street, Moonachie, N.J. 07074.

Circle 42 on reader service card

**AM/FM STEREO TUNER, model TX-9100** has stabilized, drift-free front end that uses three dual-gate MOS FET's, buffer circuit in local oscillator and front end with 5-gang variable capacitor



mounted in a die-cast frame and has two tuned rf stages. The i.f.'s use four double-tuned phase linear ceramic filters coupled with a 6-stage limiter by four monolithic IC's with differential amplifiers. Multiplex section uses phase lock loop integrated circuit. Automatic pulse noise suppressor eliminates man-made noise. Muting can be used at two different working levels—to eliminate interstation noise and cut out unwanted weak FM stations. Independent AM/FM output level controls. Signal to noise ratio: 75 dB; frequency response: 20 Hz to 15 KHz + 0.2dB, -2.0 dB. \$299.95.—**U.S. Pioneer Electronics Corp.**, 178 Commerce Road, Carlstadt, N.J. 07072.

Circle 43 on reader service card

**STEREO AMPLIFIER, KA-4004** has a continuous power output of 18 watts per



Channel rms and uses direct coupling between output circuits and speakers. Unit is shown with matching **KT-4005** tuner. Flat frequency response from ultra-low to highest ranges, low distortion at all power levels up to rated output and high damping factor even at subsonic frequencies. Protection circuit prevents damage to transistors or speakers from excessive current flow. Accommodates two tape decks with provision for mutual dubbing. Inputs for two phonos, tuner and two auxiliary inputs. Speaker terminals for two sets of stereo speakers. Features include bass and treble tone controls with tone defeat, high and low filters, loudness and muting switches, speaker mode control and front panel headphone jack. \$189.95.—**Kenwood**, 15777 South Broadway, Gardena, Calif. 90248.

Circle 44 on reader service card

**FIBER OPTIC LAMP KIT, OP8083** contains the lamp base, bulb, electrical ac-



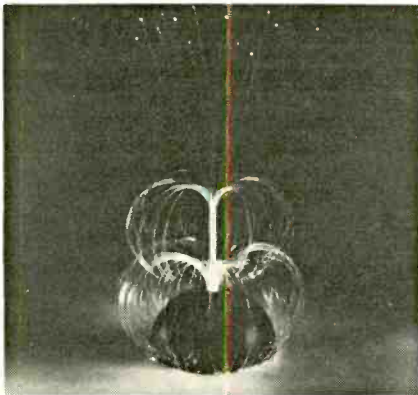

cessories and a preformed Fiber-optic spray ready to insert into the lamp base; \$10.30.—**International Rectifier Corporation**, 233 Kansas Street, El Segundo, Calif. 90245.

Circle 45 on reader service card

**NONLINEAR LOW-PASS FILTER**, model 1P1 sharply rejects noise spikes while passing signal without attenuation or in-



roduction of phase distortion. Ideal for use as noise limiter in audio section of receiver; also reduces crackling sound caused by scratches on a phonograph record without deteriorating the high frequency signal.

Dissipates energy in noise spikes by absorbing noise energy and returning the energy at the resonant frequencies of the filter. Two external capacitors determine corner frequency which can be set from dc to 20 KHz. Power supply voltage of  $\pm 15$  volts or  $\pm 12$  volts is required for the 2.56" x 2.56" x 0.9" module; \$100.00.—**Non Linear Filters**, P.O. Box 338, Trumbull, Conn. 06611.

Circle 46 on reader service card

**RADIO TEST METER**, model P5425 features a 0 to 25-watt scale and a 0 to 250-watt scale with accurate calibration for checking business radio transceivers in the 25-50-MHz band. Provides service shops with all test functions needed to service any type transceiver. Crystal ac-



tivity can be checked as well as a complete range of other transmitter and receiver functions.

On the 25-watt scale, there is a built-in dummy load. On the 250-watt scale, there is a through-line power measurement so the antenna can be kept in the line if desired or an accurate external dummy load connected for precise measurements.—**Pace Communications**, Box 306, Harbor City, Calif. 90710.

Circle 47 on reader service card

**ALARM SYSTEM KIT**, model Y-1000-A is identical to its predecessor, Y-2000-A,



except that it is packaged without the cabinet and must be assembled by the user. When an intrusion is attempted, the magnetic contacts latch, energizing the alarm siren. Special fire detection circuit sounds the siren if temperature exceeds 135°F sensor limit. System operates on 12V dc.

Kit includes a heavy-duty speaker

horn, solid-state control center, two heavy-duty 6-volt batteries, security shunt lock (on/off) with two keys, package of mounting hardware, door or window decal, 150 feet of black and yellow conductor wire, 2 UL approved magnetic switches, 2 UL approved 135° fire sensor switches, instruction sheet and guarantee. Has built-in test equipment; \$89.95.—**Idea Systems Inc.**, 101 North Duane Avenue, Endicott, N.Y. 13760.

Circle 48 on reader service card

**REEL & STORAGE CASE**, LR-7M. 7" reel with standard slotted hub is made of anodized aluminum. Assures accurate alignment and wrap-up of tape during recording, playback, rewind and fast-forward operation.

Library-shelf storage case, made of high-strength polystyrene plastic, has a hinged cover with self-locking latch that



opens instantly but cannot open accidentally. Complete package with blank self-stick labels in factory sealed wrapper—\$10.50.—**TDK Electronics Corp.**, 23-73 48th Street, Long Island City, N.Y.

Circle 49 on reader service card

# Pix-Mate™ the crt tester you can afford to take along

only ... \$34.95



- A quality CRT tester with individual test for each gun.
- Compare guns for emission.
  - Test for leakage and shorts.
  - Legible 3 color scale.
  - Compact, portable, rugged.
  - Avoid recalls, check the CRT on every call.

WRITE US!

## TeleMatic

take along the time savers

- PIX-MATE • CRY-S-MATE • GEN-MATE
- SOUND-MATE • TRACE-MATE

The Caddy-Mate Line.

2245 PITKIN AVE., BROOKLYN, N. Y. 11207

Circle 23 on reader service card

JULY 1973 • RADIO-ELECTRONICS 81

## beat the heat with this handy little heat sink

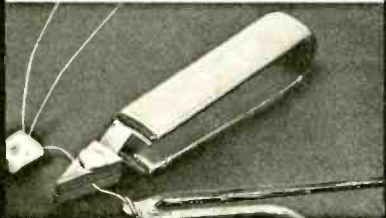

This is No. 80, Xcelite's little gem for absorbing and dissipating heat when soldering fine wires or working close to delicate electronic components. Solder won't adhere to copper jaws because they're nickel plated. They're spring loaded to "stay put" and have a smooth surface to avoid marring or scratching.

Insulating cushion grips protect fingers. Made in U.S.A. to highest standards.

### Request Free Tool Catalog

nationwide availability through local distributors



XCELITE, INC.

10 Bank Street, Orchard Park, N.Y. 14127  
In Canada contact Charles W. Pointon, Ltd.

## nothing like this RG59/U coax stripper/cutter

Meet No. 590 . . . designed specifically for RG59/U Coax Cable. With three-position lever in selected position, it cuts and strips:

- 1 Jacket, shielding, and dielectric cleanly from conductor.
- 2 Jacket and shielding only.
- 3 Jacket only.

With lever disengaged, it cuts through entire cable.

Cushion grips for comfort. Made in U.S.A. to highest standards.

Request Free  
Tool Catalog

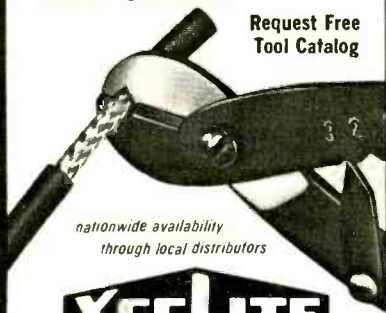

nationwide availability  
through local distributors



XCELITE, INC.

10 Bank Street, Orchard Park, N.Y. 14127  
In Canada contact Charles W. Pointon, Ltd.

Circle 24 on reader service card

# new literature

All booklets, catalogs, charts, data sheets and other literature listed here with a Reader Service number are free. Use the Reader Service Card inside the back cover.

**REPLACEMENT TRANSISTORS**, *Sizzling 66 Program Guide* offers the service technician a readily available replacement for foreign semiconductors used in radio, television and other home entertainment devices. Provides specifications of each item as well as outline drawings and terminal arrangements. Over 5,000 foreign types are listed along with their replacement.—**Raytheon Company**, Fourth Avenue, Burlington, Mass. 01803.

Circle 50 on reader service card

**ELECTRONIC PHOTOFASH PARTS** brochure lists electronic ignition parts, transistor coils, ballasts and resistors, ignition system kits, transistors and diodes, rectifiers, silicon controlled rectifiers, emergency warning light flasher switches, tachometer buffer amplifier, voltage regulators, and more.—**W. F. Palmer Electronics Laboratories**, Carlisle, Mass.

Circle 51 on reader service card

**STEREO SOUND REPRODUCERS** is a 14-page brochure that contains cartridge selection guide, super-track "plus" cartridges, deluxe series of high trackability cartridges, custom series of high trackability cartridges, extra durability high trackability cartridges, standard series of stereo dynetic cartridges, spherical stylus cartridges, replacement stylus chart, stylus assembly, tone arms, preamplifier, and headphone amplifiers.—**Shure Brothers Inc.**, 222 Hartrey Avenue, Evanston, Ill. 60204.

Circle 52 on reader service card

**PANEL INSTRUMENTS**, catalog D-71 is a 27-page booklet that contains custom instruments for measuring ac/dc voltage; ac/dc current and dB, in a variety of ranges. 1½" panel instruments, 2½" panel instruments, 3½" panel instruments, 4½" panel instruments, 5½"-6½" panel instruments and 7½"-8½" panel instruments are all included. Also shown are pyrometers ruggedized panel instruments and watt meters as well as accessories and dimensional drawings.—**Triplett Corp.**, Bluffton, Ohio 45817.

Circle 53 on reader service card

**TEST EQUIPMENT**, catalog BK-1 28-page catalog contains basic specifications and features plus illustrations of 26 models including oscilloscopes, color generators, tube testers, digital and analog multimeters, capacitor and transistor testers, analyzers, an rf generator and a square-wave generator. Also included are high-voltage probes and other test equipment accessories.—**Dynascan Corp.**, 1801 West Belle Plaine Avenue, Chicago, Ill. 60613.

Circle 54 on reader service card

Write direct to the manufacturers for information on items listed below:

**TV DX BROCHURE** includes basic information on TV, FM and vhf-uhf utility DXing as well as the propagation effects that cause all three. A full description of the Worldwide TV FM DX Association (WTFDA) is included.—**Worldwide TV-FM DX Association**, P.O. Box 163, Deerfield, Ill. 60659.

**LASERS**, 32-page catalog presents a line of helium-neon and cadmium lasers with outputs that range from ultraviolet and blue to red and infrared wavelengths. Laser tubes from \$59.50, complete laser from \$89.50. Charts aid the user in selecting optimum combination of tube and power supply. Also lists laser power meters, solid-state power supplies, photometers, counter timer and other laser accessories as well as nuclear physics demonstration kits and holography kits.—**Metrologic Instruments Inc.**, 143 Harding Avenue, Bellmawr, N.J. 08030 R-E

## CONNECTING BATTERIES IN PARALLEL

Two batteries—even those of identical manufacture—rarely have precisely identical output voltage. Nearly always, there will be at least a slight difference, particularly during and immediately following a discharge cycle. If two batteries are connected in parallel, the one having the higher output potential will tend to charge the one having the lower output potential. This represents a loss of power and decreased battery life.

The way to overcome this problem is shown in the schematic diagram. A diode is connected (with the proper polarity) in series with each battery, thereby forming an "OR-gate". With this connection, current can flow from either battery to the

output terminals—or from both batteries to the output terminals, if their potentials are identical—but no current can flow from one battery to the other.

Germanium diodes are preferred, since they have a lower potential hill.

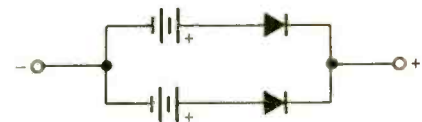

Schematic of battery connections.

This setup also provides protection for the batteries—and the circuit to which they are connected—in the event that one (or both) of them is connected with reversed polarity.—**Frank H. Tooker**

R-E

## LETTERS

(continued from page 22)

mittee and their efforts—keep up the good work.

WARREN BAKER, CET  
Baker Electronics  
Albany, N.Y.

## BURGLAR ALARMS

I have just finished an article entitled "How To Pick The Right Security System" by Mr. George S. Duryea in the May 1973 issue of **Radio-Electronics**. I would like to compliment your publication and Mr. Duryea on an informative well written article.

However, at the same time, I would like to call your attention to our GC AUDIOTEX Burglar Alarms. I am also enclosing some literature on this line of alarm products. Your readers should know that we market virtually every product that was mentioned in the article by Mr. Duryea.

In view of this, I am sure you can appreciate how greatly disturbed we were for not having been given any consideration whatsoever in the article. As the leading manufacturer and marketer of electronic products, we appreciate the value of editorial mention in highly regarded publications such as **Radio-Electronics**. At the same time, a conspicuous absence of a leading product from an article such as this one, we feel, is a serious injustice.

PAUL LAURES  
GC Electronics  
Rockford, Ill.

*You are so right! GC Electronics has a complete line of alarm systems. R-E readers; be sure to consider these devices before buying an alarm system.—Editor*

## 4-CHANNEL FEEDBACK

It might interest you to know that I read Herb Friedman's article on 4-channel sound on my way to Montreal and I thought it was so good that I clipped it out of your magazine for future reference.

I live with multichannel literature on a daily basis, reading and absorbing everything I can. I also work with our engineers spending a great deal of time discussing new trends in 4-channel in an effort to accumulate as much knowledge as possible. Herb Friedman's article gave me a closer insight into many aspects of multichannel sound that were vague in my mind. In fact, he covered several points which had eluded me completely.

With your permission, I would like to use Herb's article as reference for a lecture I am preparing on this timely topic.

I applaud the article and urge you to have Herb write many more.

LEON KUBY  
Harman-Kardon, Inc.  
Plainview, N.Y.

*Herb's a capable and prolific writer and you can be sure that he'll have more articles for the audiophile.—Editor*

## SPELL IT RIGHT

I appreciate the write up on my new Radar book, page 102 of your May 1973 issue.

What disturbs me is the fact that you have spelled my last name incorrectly!

Since an author's prime interest is that he be recognized as such and given proper credit for his work, it is of utmost importance that his name be correctly printed. Can you please correct the error.

E. L. SAFFORD, JR.  
El Paso, Texas

*Sorry about that. We'll watch it closer next time.—Editor* **R-E**



*I suppose you'll be like all the others and say it has to go to the shop.*

# FREE ALARM SYSTEMS CATALOG



Full line of professional burglar and fire alarm systems and supplies. 80 pages, 400 items. Off-the shelf delivery, quantity prices.



**mountain west alarm**  
4215 n. 16th st.  
phoenix, az. 85016

Circle 28 on reader service card

*The "Country Boys" Have it!*

## New Universal Type COLOR TV YOKE



REPLACES YOKES OF OVER 200 DIFFERENT MFR'S INCLUDING HITACHI, TOSHIBA AND NIVICO

Oneida's OCY-95 Universal Color TV Yoke does it all. It's the hottest item in the marketplace ... being used in the following: Admiral, Airline, Ambassador,

AMC, Andrea, Arvin, Bradford, Catalina, Clairtone, Coronado, Curtis Mathes, DuMont, Electrohome, Emerson, Hitachi, Hoffman, Muntz, Nivico, Olympia, Packard-Bell, Penncrest, Philco-Ford, RCA, Sears Silvertone, Sylvania, Toshiba, Truetone, Westinghouse.

Standard warranty. Complete schematic and all manufacturers' part nos. enclosed with each unit.

See your local distributor. If he doesn't have it ask him to order a supply for you.



*The "Country Boys" Appreciate Your Business*

**ONEIDA ELECTRONIC MFG. INC.**  
MEADVILLE, PA. 16335



ELECTRONIC  
MFG. CO.

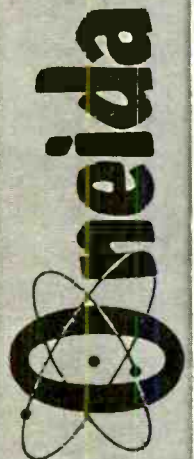

Circle 25 on reader service card

# ELECTRONIC TECHNICIANS!

Raise your professional standing and prepare for promotion! Win your diploma in

## ENGINEERING MATHEMATICS

from the Indiana Home Study Institute

We are proud to announce two great new courses in Engineering Mathematics for the electronic industry.

These unusual courses are the result of many years of study and thought by the President of Indiana Home Study, who has personally lectured in the classroom to thousands of men, from all walks of life, on mathematics, and electrical and electronic engineering.

You will have to see the lessons to appreciate them!

NOW you can master engineering mathematics and actually enjoy doing it! WE ARE THIS SURE: you sign no contracts—you order your lessons on a money-back guarantee.

In plain language, if you aren't satisfied you don't pay, and there are no strings attached.

Write today for more information and your outline of courses.

You have nothing to lose, and everything to gain!

### The INDIANA HOME STUDY INSTITUTE

Dept. RE-7, P.O. Box 1189, Panama City, Fla. 32401

Circle 26 on reader service card

## FREE catalog

over  
1000

unique tools,  
handy kits,  
precision  
instruments,  
technical  
supplies.



Our 21<sup>st</sup> year of service to the World's finest craftsmen and technicians.

**National Camera**  
2000 West Union Ave. Dept. G88  
Englewood, Colorado, 80110

Send a FREE copy of the nc Flasher

name

address

city

state

zip

**National Camera**  
2000 West Union Ave. Dept. G88  
Englewood, Colorado, 80110

Circle 27 on reader service card

84 RADIO-ELECTRONICS • JULY 1973

# appliance clinic

## REVERSING AC MOTORS

by JACK DARR  
SERVICE EDITOR

DC ELECTRIC MOTORS WILL OFTEN RUN the other way if the battery polarity is reversed. How do you reverse the rotation of an ac motor? In any one of several ways. Some ac motors aren't easily reversible; synchronous types as used in clocks, phonograph turntables, and so on. Some of these can be reversed, if necessary, by taking them apart and putting the field and frame back upside down. You can make a phono-turntable run backward by doing this; especially if the motor has been taken apart for cleaning.

In the common repulsion-induction fractional-horsepower motor, used on many larger appliances, the rotation can be reversed by reversing the leads of the starter winding only. A lot of replacement-type motors have the starter leads brought out to a terminal box on the frame, just for this purpose. Only the starter-winding leads need be switched; the running windings don't care which way the thing goes. In fact, with the starter winding disconnected and power applied, the motor can be started either way by spinning the shaft by hand. In service work, motor-reversing isn't too common, but it's handy to know how, if you have to.

There are quite a few applications which need an easily-reversible motor. Garage door openers and TV antenna rotators are two examples. The motors used for this purpose are basically all the same, though sizes differ with the power needed. This is called a "capacitor-run" motor and has two windings. Fig. 1 shows the circuit. Both of

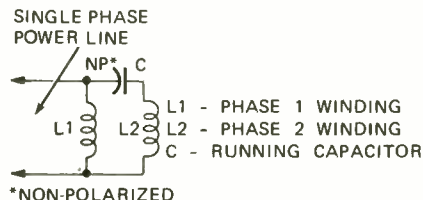

FIG. 1—DIRECTION MOTOR RUNS is determined by winding in series with capacitor.

the windings stay in-circuit at all times; one isn't disconnected by the starter-switch.

The running capacitor causes a phase-shift of the voltage and current across it. This type of motor actually operates as a two-phase motor, though the ac line supply is single phase. This type of operation gives the motor far greater efficiency, by improving the power factor. For a given amount of power, this motor draws much less current from the line.

These motors can be reversed by simply switching the connections of the two windings to the hot side of the line; the common stays connected to the other side. In TV antenna rotators, this is done by a simple manual switch. Figure 2 shows how. (These

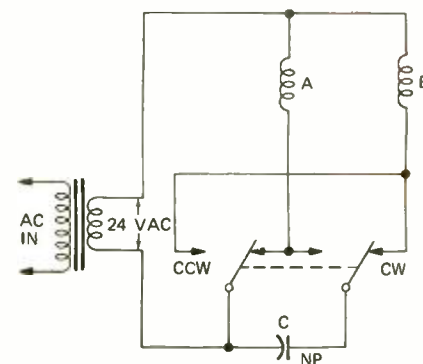

FIG. 2—MOTOR REVERSING SCHEME for antenna rotator. Capacitor does the job.

are low-voltage motors that run on 24 volts ac from a transformer) with the switch in the CW position, winding A is connected directly to the line, and winding B is connected through capacitor C. With the switch turned to CCW position, A is now fed through the capacitor, and B directly from the line. In the typical antenna rotator, C is a non-polarized electrolytic capacitor of about 100  $\mu$ F, rated at 150 volts ac. Motors are small and run the thing through gear-trains.

For heavier loads, such as garage-door openers, the motors will be bigger; still geared down for more power. They run directly from the ac line. However, circuitry and operating principles are exactly the same. If one winding is connected directly to the hot side of the line and the other

through the capacitor, the motor runs one way. Reverse these connections and it runs the other way. Switching can be done by a relay, actuated by a radio-control receiver.

Some of the early models of these units used dpdt limit-switches. Once started, the motor had to run all the way through the cycle, hitting the limit-switch and tripping it before the motor could be reversed. In later ver-

ing motors; drills and so on.

The triac reversing circuit shown here comes from the RCA *Solid State Power Circuits Designers Handbook*, Technical Series SP-52. A complete circuit for the garage-door opener unit is shown in Fig. 445, page 401. Speed control and many other circuits are shown in this useful book. **R-E**

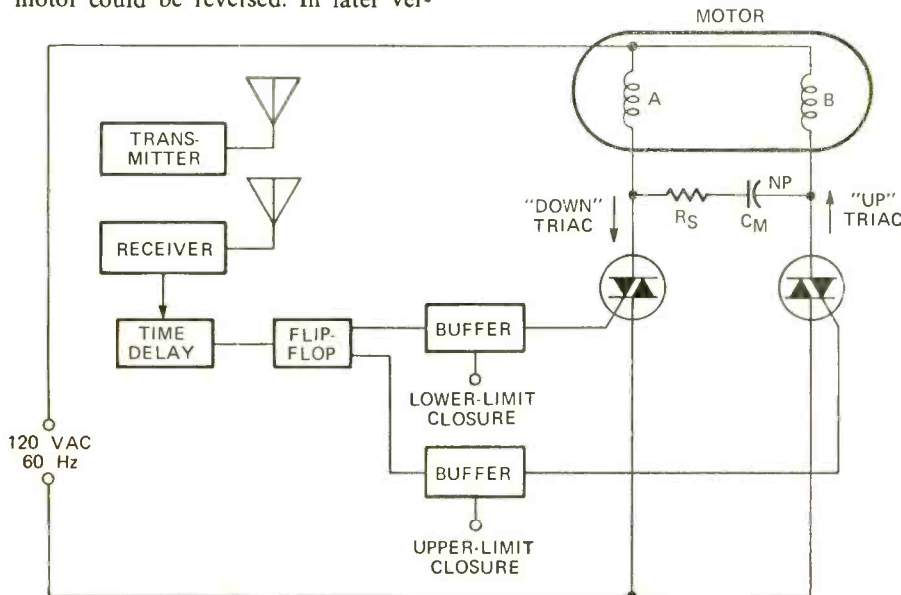

FIG. 3—SOLID-STATE SWITCH consisting of two triacs alternately turned on and off replaces the double-pole, double-throw mechanical switch in some applications.

sions, limit-switches are still used, to be sure the machinery stops when the door reaches the end of its travel, either up or down. However, directional control is now possible; the door can be stopped and started in the other direction.

When the command pulse is received from the transmitter, the receiver starts the motor running. If the door was down, it goes up, and vice versa. However, now the direction of travel can be reversed by pushing the transmitter button again. The door will stop and start in the other direction. (Which is handy, if it happens to be coming down on your foot or the car top.)

Many late models use solid-state switching. Fig. 3 shows a diagram of a circuit using two triacs, one for UP and another for DOWN. Motor windings are arranged just as before. The only difference lies in the addition of the current-limiting resistor ( $R_S$ ) in series with motor capacitor  $C_m$ .

In this circuit, if the UP triac is switched on, winding A gets current through the capacitor, and winding B directly from the triac. For DOWN, the action is the same with winding B drawing current through the capacitor. The switching between UP and DOWN is done by the flip-flop circuit in the receiver. Similar methods are used in smaller appliances which need revers-

# why pay retail?

Buy from us, save money on

# hifi

Choose from over 100 name brands, and save on time and freight charges by ordering from the location nearest you!

## Midwest Hifi

WHOLESALE & MAIL ORDER DIVISION

Send for our free catalog!  
2455b Wisconsin Ave.,  
Downers Grove, Ill. 60515  
(Attn: Ralph Edwards)  
3309 E. J. W. Carpenter Frwy.,  
Irving, Tex. 75060  
(Attn: Ron Elkins)

Circle 29 on reader service card

# TUNE-IN

on these TOP-RATED 'NO-NOISE' PRODUCTS

PROVEN PERFORMANCE FOR COLOR AND B/W

**FIRST**, simply spray parts with **SUPER SPRAY BATH**. Dissolves and flushes away grease, dirt, oil and oxidation—penetrates action cleans and restores all component parts.

**THEN**, follow with **VOLUME CONTROL AND CONTACT RESTORER** for special attention to volume controls, push button assemblies, band switches, relays and other electrical contacts.



'NO-NOISE' products are guaranteed: non-flammable, no carbon test, non-toxic—safe for plastics.

For Tuners (incl. wafers type) use **TUNE TONIC** With Peema Film OR **SUPER LUBE** for further cleaning and lubrication—economical, a little does a lot.



Other Famous 'NO-NOISE' Products  
• EC-44 • Frigid Air • Tape-Recs Head Cleaner

Often imitated but never duplicated

**ELECTRONIC CHEMICAL CORP.**  
813 Communipaw Avenue Jersey City, N. J. 07304

Circle 61 on reader service card

# DISCOUNT PRICES TEST EQUIPMENT



Catalog & Prices on Request

**FORDHAM** Radio Supply Company, Inc.

558 Morris Ave. Bronx, N.Y. Tel: (212) 585-0330 **RCA**

DISTRIBUTORS OF ELECTRONIC SUPPLIES

Circle 62 on reader service card

# technotes

## 75A149 SLIDE CONTROLS

Admiral can now supply a replacement slider for the 75A149 series slide controls. This enables you to make the repair without replacing the control (no soldering). Remove the control cluster, pry up the ears on the face of the control, lift out the slotted Bakelite panel and remove the broken slider. Transfer the contact spring to the replacement slider and reassemble.

Two sizes of sliders have been used. The longer of the two will be supplied. Snip off the excess length when replacing the short slider. The part number of the slider is 98A149-1.—*Admiral Service News Letter*

## G-E JA TV CHASSIS

The neon bulb for the AUTO button is lighted whenever the receiver is on. When the button is in the OUT (unlit) position, a cork pad on the bottom of the button and a cylindrical fiberboard cover on the bulb, shield the light from the button. When the button is in the IN (lit) position, light enters the button and is reflected to the front by a prism inside the button.

If the cover of the bulb is improperly positioned, the button may be partially lit when it is in the OUT (unlit) position. To correct this, dismount the remote receiver and

move it aside to allow access to the area under the AUTO button. Then insert the rubber eraser end of a pencil under the button, and rotate the fiber cover until it shields the

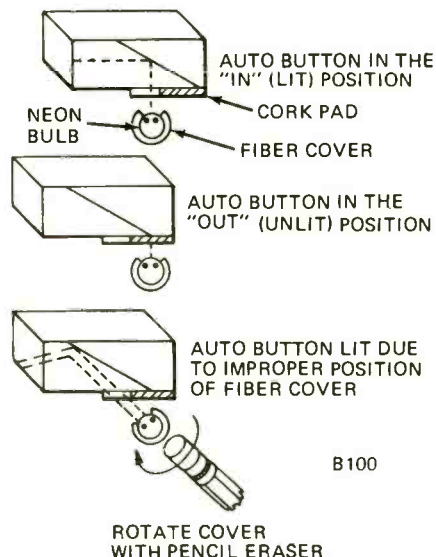

## AT LAST! PROFESSIONAL HOME PROTECTION EVERYONE CAN INSTALL AND AFFORD.

Model FC-100  
WIRED \$69.95



- Start your custom Burglar/Hold-up/Fire Alarm System with the FC-100. Add on Sensors, Alarms and Accessories to suit your own needs.
- "Do-it-Yourself" Installers Handbook included. No technical knowledge needed — No soldering.
- 100% Professional in Design, Reliability, Performance.



**'Fail Safe'-SYSTEM BY EICO**

A New Concept in "Do-it-Yourself" Home Protection

### FREE 32 PAGE EICO CATALOG

For latest catalog on EICO Test Instruments, Stereo, EICOCRAFT Projects, Environmental Lighting, Burglar/Fire Alarm Systems, and name of nearest EICO Distributor, check Reader Service Card or send 25¢ for First Class mail service.

EICO, 283 Malta Street, Brooklyn, N.Y. 11207



light from the button when the button is in the OUT position.

Due to light leakage, a small amount of light may always be emitted from the button. This will only be visible in a very dark room.—*General Electric Service Information*

## RCA KCS 146A/B/DE CHASSIS

The raster was normal with snow when tuned off-channel. When tuned to a local channel there was sound but no picture or snow. Agc control had no effect.

The trouble was traced to the voltage divider in the

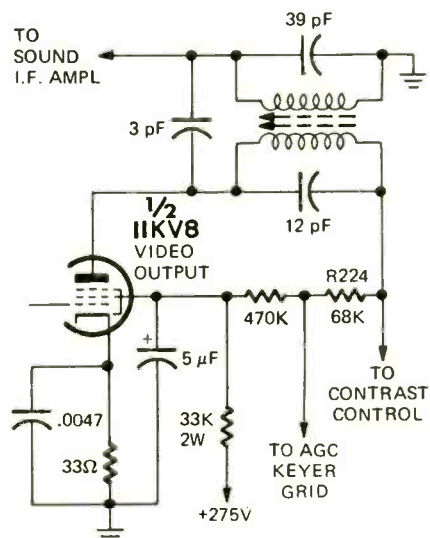

plate circuit of the 11KV8 video amplifier. The bias on the control grid of the 6GH8-A agc keyer was near normal but could not adjust automatically over the required range so excessive agc voltage was developed. Resistor R224 had

increased from a normal value of 68,000 ohms to nearly 300,000 ohms.

The solution is to replace R224 with a higher quality resistor. I recommend Allen-Bradley.—*Richard L. Koelker*

### UNCONTROLLED BRIGHTNESS

The 6GK6 video output tube was replaced in this Setchell-Carlson U802 TV chassis in an attempt to restore normal brightness. The BRIGHTNESS CONTROL had very little effect. Voltage measurements on the 6GK6 indicated very

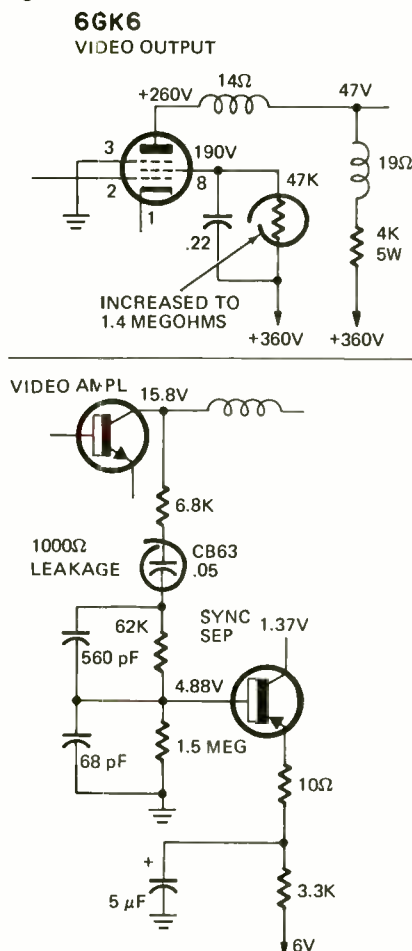

low screen voltage (+47 volts). The screen resistor had increased to 1.4 megohms. Replacing it with a 47,000-ohm restored normal operation.—*Homer L. Davidson* **R-E**

### NEXT MONTH

Looking for new ways to increase your income? Aren't we all. In the August issue of **Radio-Electronics** we will present three new areas of electronics that call for repairs by technicians. They are calculators, microwave ovens, and telephone answering machines. Take a look at how easy these devices are to repair. Don't miss the August issue. On sale at your newsstand on July 19.

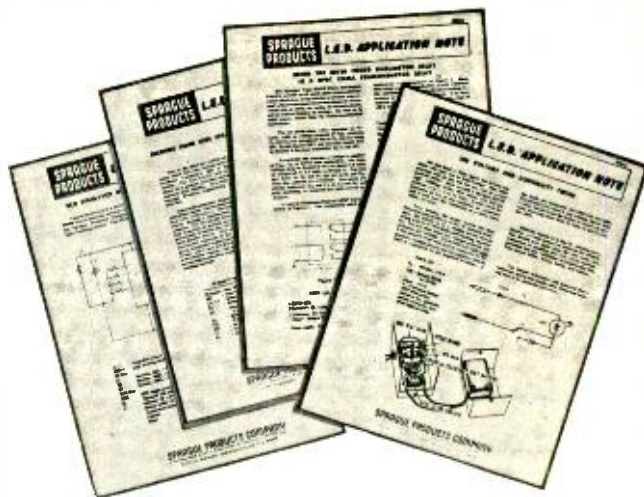

# FREE

## L.E.D. Application Notes to help you do new things with new circuits!

Now . . . get four free Application Notes hot-off-the-press that describe various uses and circuits for Sprague LED devices. Notes cover a BCD simulator, seconds timer, voltage and continuity tester, and an all-solid-state semiconductor relay. They've been prepared specifically to help open up a new world of electronic experimentation for **YOU**.

Ask your distributor for copies, or write our Guy Ezelle at Sprague Products Co. Better yet, fill out and mail coupon today!

**Sprague Products Company**  
81 Marshall St., North Adams, Mass. 01247  
Attention: Mr. Guy Ezelle

YES . . . send me free L.E.D. application notes on:

- BCD Simulator     Voltage & Continuity Tester  
 Seconds Timer     Semiconductor Relay

Name .....

Address .....

City .....

State .....

Zip .....



68-2117

Circle 64 on reader service card  
JULY 1973 • RADIO-ELECTRONICS 87

## SOLDERING GUN STAND

I obtained a large number of surplus PC boards and started in using

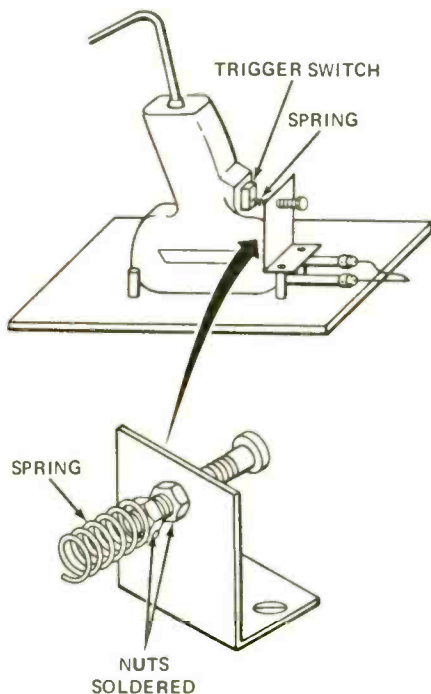

my soldering gun salvaging parts from them. My hand and fingers soon be-

came cramped so I developed the gun stand shown in the photo and drawings to simplify things and ease the strain.

The device consists of four ceramic spacers screwed to a wood base. The front two position the gun and the rear ones keep it from slipping. A short length of aluminum or steel

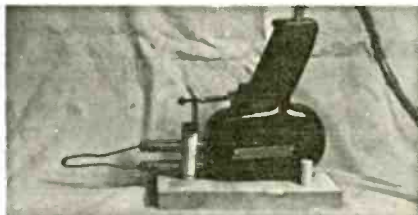

angle across the front spacers is threaded for an adjustable screw to close the trigger switch. A nut holds a spring on the end of the screw. Open the switch by pushing the spring to one side.—Peter Legon **R-E**

### NEXT MONTH

The modern electronic calculator has us surrounded. When they break down, someone has to fix them. You can learn how in the August issue.

## TEST HI-FI AMPLIFIERS

(continued from page 40)

low the mid-frequency values. If several sets of input terminals are available, measure the frequency response of each set feeding specialized input circuits and record the markings of each set of terminals.

If an amplifier provides an NAB equalized tape head input and/or an RIAA equalized phono input, compare the results of the frequency re-

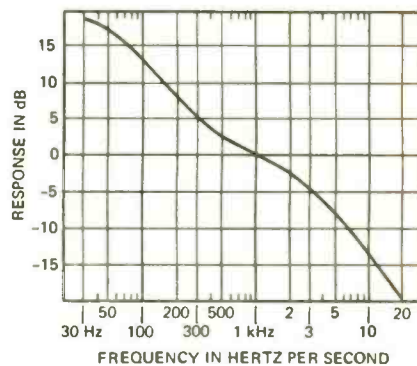

FIG. 16—STANDARD CURVE for RIAA phono input. Errors should not be great.

sponse measurements at these input jacks to the standard curve. See Fig. 15 and 16 and record the resulting error.

Fig. 17 is an example of a set of curves made for step-type controls. If

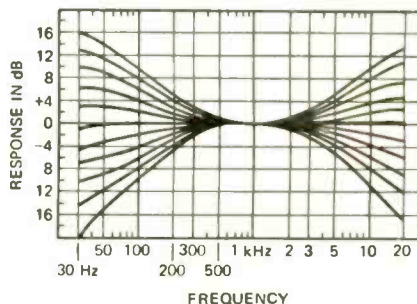
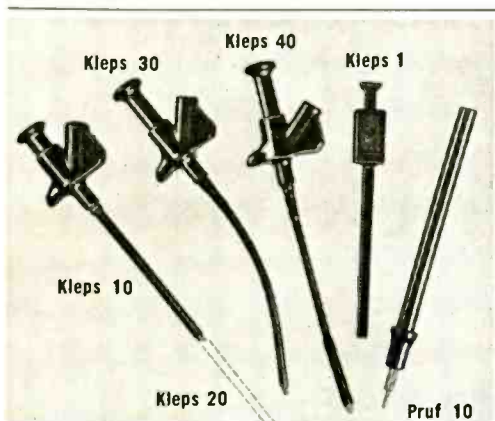

FIG. 17—TYPICAL BOOST AND CUT CURVES of stepped-type bass and treble controls.

there are tone controls that vary the operation of the amplifier continuously as the control is adjusted, make a curve of the frequency response for each control at its normal setting, in its extreme positions and at sufficient other settings to indicate the effect on frequency response at intermediate settings.

There you have it. Complete procedures for eight prime tests needed to check out any audio amplifier. These should form the basis of a test procedure conducted by the technician on every audio amplifier he has occasion to work on. They will also form the basis of a series of tests that can be used by anyone to determine the proper operating characteristics of their amplifier. **R-E**



## Clever Kleps

Test probes designed by your needs — Push to seize, push to release (all Kleps spring loaded).

- Kleps 10.** Boathook clamp grips wires, lugs, terminals. Accepts banana plug or bare wire lead. 4¾" long. **\$1.39**
- Kleps 20.** Same, but 7" long. **\$1.49**
- Kleps 30.** Completely flexible. Forked-tongue gripper. Accepts banana plug or bare lead. 6" long. **\$1.79**
- Kleps 40.** Completely flexible. 3-segment automatic collet firmly grips wire ends, PC-board terminals, connector pins. Accepts banana plug or plain wire. 6¼" long. **\$2.59**
- Kleps 1.** Economy Kleps for light line work (not lab quality). Meshing claws. 4½" long. **\$ .99**
- Prof 10.** Versatile test prod. Solder connection. Molded phenolic. Doubles as scribing tool. "Bunch" pin fits banana jack. Phone tip. 5½" long. **\$ .89**

All in red or black - specify. (Add 50¢ postage and handling). Write for complete catalog of - test probes, plugs, sockets, connectors, earphones, headsets, miniature components.

Available through your local distributor, or write to:



**RYE INDUSTRIES INC.**  
128 Spencer Place, Mamaroneck, N.Y. 10543  
In Canada: Rye Industries (Canada) Ltd.

Circle 65 on reader service card

For  
faster  
service

USE  
ZIP  
CODE

on  
all  
mail



Kleps 10 - 20



Kleps 30



Kleps 40



Kleps 1

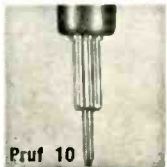

Prof 10



# SUPER SUMMER SPECIALS

FREE \$1 BUY WITH EVERY 10 YOU ORDER Only applies to "\$1" Buys FREE GIFT WITH EVERY ORDER

### SHANNON MYLAR RECORDING TAPE

2 1/2" - 225' .. \$ .17	7" - 2400' ..... \$1.79
3" - 225' .. .19	7" - 3600' ..... 2.93
3" - 300' .. .27	CASSETTE C-60 ..... .59
3 1/4" - 600' .. .58	CASSETTE C-90 ..... 1.00
5" - 600' .. .62	CASSETTE C-120 (TDK) 1.97
5" - 900' .. .80	2 1/2" TAPE REEL .... .05
5" - 1200' .. .97	3" TAPE REEL .... .06
5" - 1800' .. 1.49	3 1/4" TAPE REEL .... .07
7" - 1200' .. .77	5" TAPE REEL .... .14
7" - 1800' .. 1.12	7" TAPE REEL .... .15

### IBM COMPUTER SECTIONS

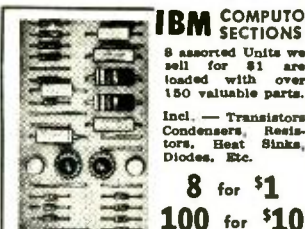

8 assorted Units we sell for \$1 are loaded with over 150 valuable parts.

Incl. - Transistors, Condensers, Resistors, Heat Sinks, Diodes, Etc.

**8 for \$1**  
**100 for \$10**

### WESTINGHOUSE ALL TRANSISTOR HOME/OFFICE MESSAGE CENTER

Leaves messages for other for replay... Built in speaker/microphone for talk-into convenience... Records up to 8 minutes of messages... Illuminated signal shows when a message is waiting. Control adjusts playback volume without affecting recording volume... Capstan Drive; BRAND NEW SOLD AS IS \$7.95

### RCA 110° FLYBACK TRANSFORMER

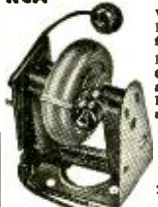

We scooped the Market Latest type - standard for all 110° TV's

RCA's design of large Coil producing 18KV assuring adequate width Incl Schematic Diagram application for any TV

List price \$13.90

Your price... **\$3**

10% off in lots of 3

- 110° TV DEFLECTION YOKE for all types TV's incl schematic..... \$3.95
- "COMBINATION SPECIAL" RCA 110° FLYBACK plus 110° DEFLECTION YOKE..... \$5.95
- 90° FLYBACK TRANSFORMER for all TV's incl schematic..... \$2.95
- 90° TV DEFLECTION YOKE for all type TV's incl schematic..... \$2.95
- 70° FLYBACK TRANSFORMER for all type TV's incl schematic..... \$2.00
- 70° TV DEFLECTION YOKE for all type TV's incl schematic..... \$2.00
- SHARP 110° FLYBACK & YOKE COMBINATION #8PT-592 Good for most portable TV..... \$5.00
- 90° COLOR YOKE For all Rectangs. 19 L9 to 25" Color CRT's..... \$10.95

### SARKES TARZIAN TUNER 41mc



Latest Compact Model good for all 41 mc TV's. BRAND NEW-

Best TUNER "SARKES TARZIAN" ever made - last word for stability, definition & smoothness of operation. An opportunity to improve and bring your TV Receiver up-to-date. COMPLETE with Tubes \$7.95

- ALL NEW TV TUNER Standard makes-less tubes..... \$1.00
- WESTINGHOUSE FM TUNER (12DT8 Tube)..... \$2.99
- WESTINGHOUSE FM TUNER #476-V..... \$3.99
- 015D01 Transistor..... \$7.95
- WELLS GARDNER TV TUNER 25A1258 (6LJ8 - 6 HA tubes)..... \$7.95
- HUF TUNER-TRANSISTOR TYPE Used in all TV sets..... \$3.95
- STANDARD TUNER-TRANSISTOR (GUIDED GRID) 4 Channel closed circuit..... \$1.00
- PHILCO TV TUNERS Model-76-18883-3 (6GJ7 - 8HQ6)..... \$4.95
- MAGNAVOX TV TUNER 340187-3 (6CG8-8CK5 tubes)..... \$7.95
- GE-STANDARD COIL TV TUNER Model EU-56X1 (6HQ5-6GJ7) Model-ET 86X304-(6LJ8-6HA5)..... \$7.95
- TV TUNERS VHF/UHF all new standard makes, including Tubes..... \$7.95
- 70° COLOR TUBE..... \$3.95
- BRIGHTNER..... \$4.95
- 80° COLOR TUBE..... \$4.95
- BRIGHTNER..... \$4.95
- CO-AX CABLE RG59U grey or black 250'-\$9 100'-\$3.69 50'..... \$2.00
- 4 - TV ALIGNMENT TOOLS most useful assortment #1..... \$1.00
- 4 - TV ALIGNMENT TOOLS For Color #1..... \$1.49
- 8 - TV COLOR ALIGNMENT TOOLS Most popular type..... \$2.79
- COLOR POWER TRANSFORMER - Good for most sets 26R150 List Price-\$36.75..... \$6.95

- 2 COLOR-TV CRT SOCKETS Wired leads, for all color TV's..... \$1.00
- 3 - RCA 110° CRT SOCKETS Wired leads, for all TV's..... \$1.00
- COLOR CONVERGENCE ASSEMBLY Uni-versal type-good for most sets..... \$2.49
- COLOR-TV RECTIFIER - Used in most color sets-6500 kv 3 for..... \$1.95
- 20 - ASSORTED TV COILS I.F., VIDEO, sound, radio, etc..... \$1.00
- 50 - ASSORTED PEAKING COILS All popular sizes..... \$1.00
- TV TWIN LEAD-IN 300 ohm 500' - \$7 100'-\$1.50 50'..... \$1.00
- 2 - COLORBURST QUARTZ-CRYSTAL For Most Color TV sets 3679.545 KC..... \$1.89
- UNIVERSAL TV ANTENNA Back of set mounting... 5 section rods..... \$1.98
- 5 ASSTD. GLOBAL VARISTOR Popular replacements for most COLOR TV..... \$1.00

### KNOB SPECIAL

- 100 - ASSORTED RADIO KNOBS All standard types \$20 value..... \$1.00
- 50 - TV KNOBS - POPULAR TYPES Mostly Selector & Fine Tuning..... \$1.00
- 25 - VERTICAL LINEARITY KNOBS Long shank... Front mount... miniature assortment..... \$1.00
- 20 - VERTICAL LINEARITY KNOBS Side mount... Standard sizes..... \$1.00
- 25 - KNURLED RADIO KNOBS Hard to get... Best selection..... \$1.00
- 40 - DELUXE RADIO KNOBS Choice assortment... Popular types..... \$1.00

ANY 6 KITS FOR \$5

- TRANSISTOR RADIO *asst type* good, bad, broken, as-is, potluck..... \$1.50
- TAPE RECORDER-assorted types good, bad, broken, as-is, potluck..... \$4.00
- 300 - ASST. 1/2 WATT RESISTORS Top Brand, Short Leads, Excellent Selection..... \$1.00
- 100 - ASST 1/2 WATT RESISTORS stand, choice ohmages, some in 5%..... \$1.00
- 100-ASST 1/2 WATT RESISTORS stand, choice ohmages, some in 5%..... \$1.00
- 70 - ASST 1 WATT RESISTORS stand, choice ohmages, some in 5%..... \$1.00
- 35 - ASST 2 WATT RESISTORS stand, choice ohmages, some in 5%..... \$1.00
- 50 - PRECISION RESISTORS *asst. list-price \$50 less 98%.*..... \$1.00
- 20 - ASSORTED WIREWOUND RESISTORS, 5, 10, 20 watt..... \$1.00
- 10-ASSORTED SLIDE SWITCHES SPST, SPDT, DPDT..... \$1.00
- 300 - ASSORTED HEX NUTS 2/66, 4/40, 5/40, 6/32, 8/32..... \$1.00
- 250 - ASST. SOLDERING LUGS best types and sizes..... \$1.00
- 250 - ASST. WOOD SCREWS finest popular selection..... \$1.00
- 250 - ASST. SELF TAPPING SCREWS #6, #8, etc..... \$1.00
- 150 - ASST. 6/32 SCREWS and 150 8/32 HEX NUTS..... \$1.00
- 150 - ASST. 8/32 SCREWS and 150 8/32 HEX NUTS..... \$1.00
- 150 - ASST. 2/56 SCREWS and 150 2/56 HEX NUTS..... \$1.00
- 150 - ASST. 4/40 SCREWS and 150 4/40 HEX NUTS..... \$1.00
- 150 - ASST. 5/40 SCREWS and 150 5/40 HEX NUTS..... \$1.00
- 500 - ASSORTED RIVETS most useful selected sizes..... \$1.00
- 300 ASSORTED WASHERS most useful selected sizes..... \$1.00
- 100 - ASST. RUBBER BUMPERS for cabinet bottoms - other uses..... \$1.00
- 100-ASSORTED RUBBER GROMMETS best sizes..... \$1.00
- 10-ASSORTED DIODE CRYSTALS 1N34, 1N48, 1N50, 1N64, etc..... \$1.00
- 5 - TOP BRAND SILICON RECTIFIERS 1 amp, 1000 PIV..... \$1.00
- 5 - PNP TRANSISTOR general purpose, TO-5 case..... \$1.00
- 5 - NPN TRANSISTORS general purpose, TO-5 case..... \$1.00
- 50 - ASSORTED TRANSISTORS big factory scoop-sold as-is..... \$1.00
- ALL AMERICAN TUBE KIT (12AV6-12BE8-12BA6-35W4-50C5)..... \$2.99

### TEST EQUIPMENT SPECIAL DISCOUNT PRICES

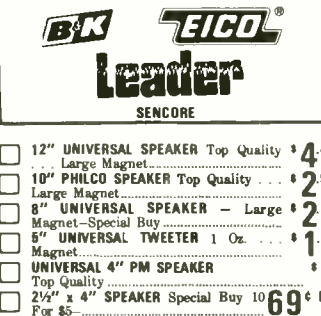

**Leader** SENCORE

- 12" UNIVERSAL SPEAKER Top Quality \$4.89
- 12" Large Magnet..... \$4.89
- 10" PHILCO SPEAKER Top Quality \$2.99
- Large Magnet..... \$2.99
- 8" UNIVERSAL SPEAKER - Large Magnet-Special Buy..... \$2.99
- 5" UNIVERSAL TWEETER 1 Oz. Magnet..... \$1.29
- UNIVERSAL 4" PM SPEAKER Top Quality..... \$1.00
- 2 1/2" x 4" SPEAKER Special Buy 10 For \$5..... \$69
- 4" x 8" "QUAM" 16 OHM SPEAKER Large magnet... Special BUY (10 for \$15.00)..... \$1.79
- 1 - 5" SPEAKER with output transformer..... \$1.39
- 6" PHILIPS "INVERTED CONE" SPEAKER Top quality... Thinline..... \$2.29
- 1-8" x 9" HEAVY DUTY 10 OZ. SPEAKER Ceramic Type... 8 Ohm..... \$3.95
- UTAH 8" - HEAVY DUTY 10 OZ. SPEAKER Ceramic Type - 8 Ohm..... \$3.95
- ENCLOSURE WITH 6" SPEAKER Excellent value, regularly \$14.96..... \$5.95
- 6" UNIVERSAL SPEAKER Top quality Special buy Ea..... \$1.29
- ELECTROSTATIC TWEETER SPEAKER for FM, HI-FI, etc..... \$1.00
- STEREO CAR SPEAKER SET Deluxe Stereo Mount..... \$6.50
- RCA 2 SPEAKER AM-FM CHASSIS Deluxe front panel, good for wall mount..... \$20.00
- 20 - DIPPED MYLAR CAPACITORS 01-600V..... \$1.00
- 20 - DIPPED MYLAR CAPACITORS .033-600V..... \$1.00
- 20 - DIPPED MYLAR CAPACITORS .033-1000 V..... \$1.00
- 20 DIPPED MYLAR CAPACITORS .047-400 V..... \$1.00
- 15 - MOLDED TUBULAR CAPACITORS .068-400 V..... \$1.00
- 20 - DIPPED MYLAR CONDENSERS .0039-400 V..... \$1.00
- 10 - SPRAGUE "ORANGE DROP" CAPACITORS 0056-2000 Volt..... \$1.00
- 3-ELECTROLYTIC CONDENSERS 100 mfd.-100 V, 50 mfd.-75 V..... \$1.00
- 2-ELECTROLYTIC CONDENSERS C.D. 500 mfd-200 volts..... \$1.00
- 2-ELECTROLYTIC CONDENSERS UNECAP 1 - 2000/1000 Mfd. . 80 Volt..... \$1.00
- 2-SPRAGUE Elec. CONDENSERS 80/30/4 Mfd. - 475 V..... \$1.00
- 1 - ELECTROLYTIC CONDENSERS 200 mfd 200V..... \$1.00
- 2 - ELECTROLYTIC CONDENSERS 1500 mfd - 85V..... \$1.00
- 6 - MINIATURE ELECTROLYTIC CAPACITORS 5MFD-150 V..... \$1.00
- 12-MINIATURE ELECTROLYTIC CONDENSERS For Transistor & miniature work..... \$1.00
- 2 - ELECTROLYTIC CONDENSERS 200/30/4 mfd - 350V..... \$1.00
- 4-ELECTROLYTIC CONDENSERS 75/30mfd-150v..... \$1.00
- 4-50' HANKS HOOK-UP WIRE assorted colors..... \$1.00
- 100'-SPOOL SPEAKER WIRE 2 cond. mini zip, clear, 101 uses..... \$1.50
- 10 - ASST. RADIO & TV TUBES Every Tube a good number..... \$1.00
- 5 - AUDIO OUTPUT TRANSFORM Sub-min for Trans Radios..... \$1.00
- 15 - MINIATURE 456KC IF TRANSFORMERS PC 1/2" X 1/4" - good value..... \$1.00
- 1 - BURLER DOOR ALARM WITH CHAIN sets off loud alarm... easy to install..... \$3.49
- PANASONIC TRANSISTOR 2SB473 (Eqv. HEP 642)..... \$1.00
- POWER TRANSISTOR 2N176 (Eqv. HEP 623) 2 for..... \$1.69
- RCA TRANSISTOR SK-3018 5 for..... \$1.00
- 5" X 7" SPEAKER 20 Ohm impedance..... \$1.00
- 3 1/2" ROUND SPEAKER Special buy..... \$5.95
- ROCKER TOGGLE SWITCH DPDT Lat est type 4 for..... \$1.00
- 50-CERAMIC TUB TYPE-(GIMMICKS) Low capacity range..... \$1.00

### MARKET SCOOP COLUMN

KLEPS "CLEVER" TEST PRODS "Third-hand" test prods, reach into out of way places - Insulated - cannot slip - accommodates bare wire or banana plug-no soldering.

- PRUF 10 - VERSATILE TEST PROBE..... \$1.79
- KLEPS 10 - BOATHOOK CLAMP 3/4" long..... \$1.19
- KLEPS 20 - BOATHOOK CLAMP 7/8" long..... \$1.39
- KLEPS 30 - FLEXIBLE-FORMED TONGUE 6" long..... \$1.47
- KLEPS 40 - FLEXIBLE-PC BOARD TERMINALS 6 1/4" long..... \$2.39
- KLEPS 1-ECONOMY KLEPS-FOR LIGHT WORK..... \$1.99

IMMEDIATE DELIVERY... Scientific light packing for safe delivery at minimum cost. HANDY WAY TO ORDER... Send check or money order, add extra for shipping. Lists of new offers will be returned in your order.

Please specify refund on shipping overpayment desired:  CHECK  POSTAGE STAMPS  MERCHANDISE (our choice) with advantage to customer

**BROOKS RADIO & TV CORP., 487 Columbus Ave., New York, N. Y. 10024** 212-874 5600 TELEPHONE

Circle 66 on reader service card

# Digital Multimeter



YOUR personal Digital Multimeter is here! The functions you need most — at the right price — with no sacrifice in quality. Full factory warranty.

- \* Autopolarity
- \* 100% Overrange
- \* LSI & C/MOS Circuitry
- \* Large 0.55" Digits

**\$145**

### SPECIFICATIONS FOR MODEL 3000

DC VOLTS	1, 10, 100, 1000
AC VOLTS	1, 10, 100, 1000
OHMS	1K, 10K, 100K, 1M, 10M
RESOLUTION	0.1% All Ranges
ACCURACY	
DC & OHMS	0.5% ± 1 Digit
AC	1.0% ± 1 Digit
POWER	105-125 VAC 60 Hz 3W

Payment with personal check, money order, BankAmericard, and Master Charge card acceptable. Include all raised information on charge cards. Net 30 days to well rated firms. No COD orders. Add \$3 for postage and insurance.

EXPORT model available. Write for details.

**LINEAR DIGITAL SYSTEMS corp.**  
P.O. BOX 954 GLENWOOD SPRINGS, COLORADO 81601

Circle 67 on reader service card

# TV REPAIRMEN!

## New! MASTER TV TROUBLE GUIDE

Over 1500 SYMPTOMS and CURES! The closest thing to magic yet in print! Covers all American and most Japanese chassis. 1962 thru 1973. We designed this guide to provide complete service experience on any set you're likely to service. No artificial symptoms, only actual field breakdowns listed. Filed by brand and chassis, for instant accessibility. With indexed tabs. The Price: \$12.95 (Color)—Also Available: Master B&W T.V. Trouble Guide: \$8.95

Note: These guides were designed by professional technicians for use with "Photofact" (Sams) Libraries.

Order Direct from:

**SERVICERS DATA CO.**

P.O. Box 9391 Denver, Colo. 80209

Circle 68 on reader service card

# circuits

## ELECTRONIC COIN TOSS

As a correspondence-school student I find that you must experiment with actual devices to really develop a knowledge of any segment of electronics. Here is a circuit I developed as an

introduction to two high-technology devices—TTL IC's and LED's. It is an IC/LED version of the Coin Tossing (See "Electronic Coin Tossing", *Popular Electronics*, January, 1956). It is so

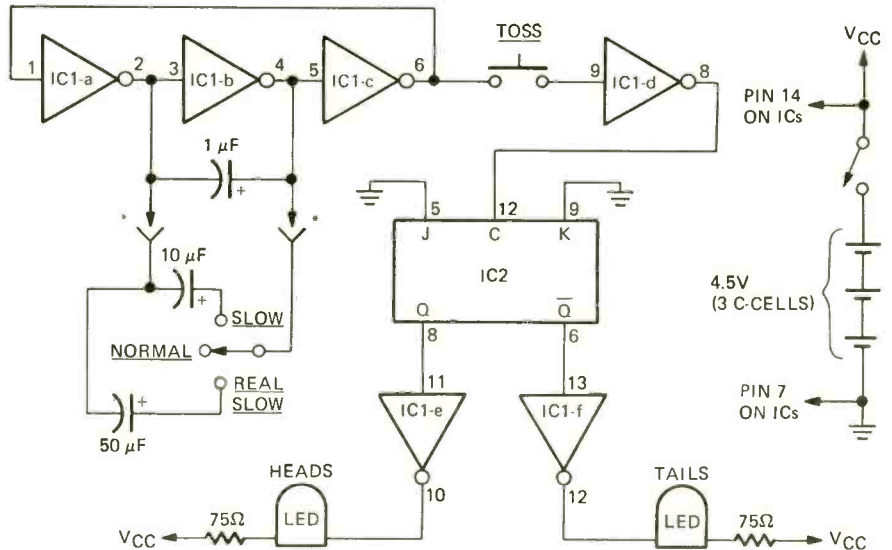

\*OPTIONAL  
IC1 TTL **7405** HEX INVERTER  
IC2 TTL **7470** J-K FLIP-FLOP

simple that the schematic shown should suffice. Parts are readily available.—*John Goegl, WA2LJK*

## LONG TIME-DELAY

The largest value of resistance ( $R_{max}$ ) that can be used in an R-C time delay with a negative-resistance device is:

$V_s - V_p / I_p$ ; where  $V_s$  is supply voltage,  $V_p$  is peak-point voltage and  $I_p$  is peak-point current. Inexpensive UJT's require up to 5  $\mu A$  to fire, trigger diodes 200, the stable D13P1 silicon unilateral switch 500. In a typical application of the 2N2646 on a 24-volt supply and firing at 15 volts.  $R_{max}$  is:

$24V - 15V / 5\mu A = 1.8$  megohms  
With a 20- $\mu F$  capacitor and 1.8 megs, the UJT switched reliably at 30-second intervals to alternate two test signals so a technician several miles away could locate both series and shunt faults in a cable.

When an inexpensive FET is used to deliver the peak-point current as in the diagram, 1.0  $\mu F$  and 43 megohms gave the same timing; doubling R1 increased the switching to once per minute. When the FET is an insulated-gate type, the size of R1 is limited only by the leakage of the

timing capacitor (C1) and the circuit insulation.

In the diagram, R1 and C1 do the timing. R2 protects the FET gate after firing and R3 limits drain current to

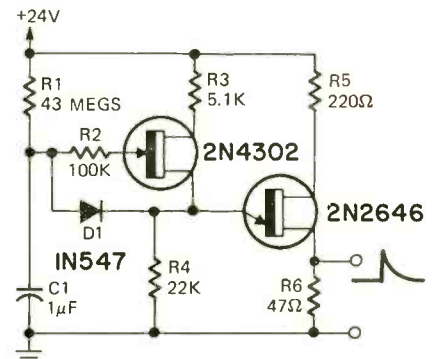

the FET's rating. R4 conducts FET current before firing and reverse-biases D1. D1, which must have a high reverse resistance, bypasses discharge current around the FET after firing. R5 can be adjusted to compensate for temperature. The output pulse across R6 fires an SCR.—*A. H. Taylor R-E*

**TROUBLESHOOTING LOGICALLY**

(continued from page 49)

Looking at what is left, there are only two points to measure, point c and point g. Since any defect in Q2 or D1 (or both) would cause a voltage other than zero to be present at point e, point c is the place to take a reading.

As for the final diagnosis, if you said "R1 open" instead of C1 shorted, you still passed the test. It takes an ohm-meter measurement to be really sure.

**Part 2: c, b, 2, C5 (shorted)**

Since we are feeding a known good signal into the input and getting no output, the first check should "cut it in half", and point c is the halfway mark.

Given the result of "no output" at point c, the next logical measurement point is point b, since the trouble is in the first two stages and point b gives you the information necessary to decide which stage is defective.

With point b providing a signal to Q2, it is obvious that stage 2 is defective, and that the transistor voltage readings given are for Q2.

How about the final diagnosis? Let's look at what *isn't* wrong. If Q2 were open, the collector voltage would be 28V, but the base voltage would not be 0V. If Q2 were shorted, the collector voltage would not be any where near 28V. **Conclusion**—Q2 is all right. R7 must be OK since the collector of Q2 reads 28V. R6, R8, and R9 must be OK because the only defect that could give the

set of readings we have is R8 shorted, and shorted resistors are rare! What is left? C5, right across R8, and if it is shorted, we get the symptoms given!

**Part 3: Input (or power supply voltage), power supply voltage (or input), c, b, 2, Q2 shorted.**

This part of the test required you to go back to the beginning of troubleshooting and check the simple things first. The symptom was no output—does the circuitry have an input? Does it have the proper power supply voltage supplied? (Either order is OK for these two steps.) Since both of those requirements are present, cut it in half troubleshooting is the procedure that seems to be called for. The halfway mark, according to the block diagram, is point C. No signal was present so we cut the two stages that are left in half by checking point b. Since the signal is present at "b" and missing at "c", stage 2 is defective.

In the final diagnosis Q2 shorted looks like the culprit based on the voltage readings given for the defective stage.

If you got two out of three parts right, you can call yourself a troubleshooter!

**ATTENTION TROUBLESHOOTERS**  
That wraps up this 4-part series on troubleshooting techniques. But it is far from the end of troubleshooting articles that will appear in **Radio-Electronics**. Each issue will continue to present another installment of Step-By-Step Troubleshooting by Stan Prentiss. Don't miss it.

HERE ARE THE ANSWERS TO LAST MONTH'S QUIZ.

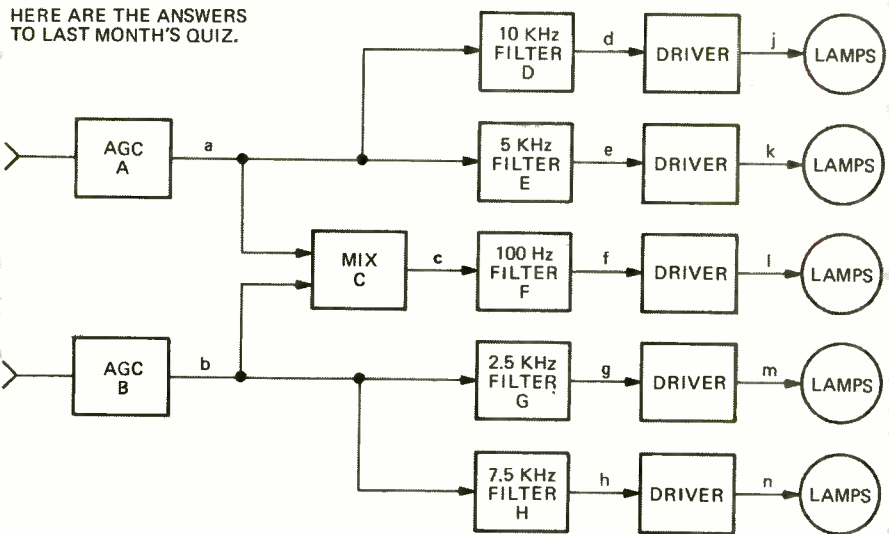

SYMPTOM - 100 Hz OUTPUT MISSING

1ST MEASUREMENT POINT POINT f

THE AGC STAGES ARE WORKING BECAUSE ALL OTHER OUTPUTS ARE OK, THE POWER SUPPLY IS OK FOR THE SAME REASON, AND LOOKING AT POINT f CUTS THE AREA THAT APPEARS DEFECTIVE "IN HALF."

2ND MEASUREMENT POINT POINT c

DEFECTIVE STAGE STAGE c

THE INPUTS TO STAGE c ARE ALL RIGHT FOR THE REASONS ABOVE. THE OUTPUT IS DEFECTIVE, SO STAGE c IS "IT".

# SPRAY AWAY THE RACKET.



Squeak. Whine. Whirr. Pss! Silence. Quietrol did it again, Silenced those moving T.V. parts, with one squirt from the handy spray pack. Cleaned away dirt, dust, and crud. Without damaging anything... in any black and white or color set. Silence is golden. So is Quietrol.

Also available in bottles, and the new Silicone—"Silitron."

Product of



**QUIETROL**  
COMPANY

Spartanburg, South Carolina

Circle 69 on reader service card

Assorted untested diodes. All new with full leads. Spot check shows about 75% good useable units. Many, many Zeners, some 400 mw, some 1 Watt, some 3 Watt. Also power diodes. Put those testers to work and save dollars. About 1200-1400 pieces per pound. PRICE is a low — \$6.00 for half pound ppd. or \$10.00 for a full pound ppd.

Power Transformer. 115 Volt AC Primary. Secondary #1: 32-0-32 Volt @ 1 Amp. Secondary #2: 6.3 Volts. Low Current For Pilot Lights. Size 2 1/2" x 2 1/2" x 3". Price: \$2.50 Each ppd.

Transformer—American Made fully shielded. 115 Volt Primary Secondary #1 18-0-18 Volts @ 4 Amps Secondary #2 5 Volts @ 2 Amps. A very useful unit for LV Power supply use. Price — A low \$4.75 ppd.

**JUST ARRIVED**

250,000 American made disc ceramics. Almost all have full leads. All clearly marked with values. A bargain we may not repeat.  
100 Assorted \$2.00 ppd.  
500 Assorted \$7.50 ppd.  
1000 Assorted \$10.50 ppd.

Transformer, 115 VAC Primary, 12 Volt, 4 Amp Secondary \$4.00 Each ppd.

6.3 Volt 1 Amp Transformer. Fully Shielded \$1.60 Each ppd.

115 VOLT TRANSFORMER 17-0-17 Volt @ 150 ma. Secondary With Tap At 6.3 Volts For Pilot Light. \$1.50 Each ppd.

Untested TO-5 transistors. All with full leads. Some NPN some PNP some Silicon some Germanium. Spot check shows about 60% good units. 100 for \$3.75 ppd.

SEND STAMP FOR BARGAIN LIST  
Pa. Residents add 6% State sales tax  
ALL ITEMS PPD. USA

**m. weinschenker**  
K 3DPJ BOX 353 · IRWIN, PA. 15642

## MANEM

0.127" HIGH LED 7-SEGMENT  
 DISPLAYS ALL NUMBERS AND NINE LETTERS  
 COMPACT SPACING - 5 PER INCH  
 BRIGHT RED 400FT-L AT 10 MA PER SEGMENT  
 EACH.....\$3.00  
 TEN OR MORE FOR...2.50

## LED's

MV-50 RED EMITTING 10-40MA @2V •.39  
 MV-5020 RED LED •.45  
 MV-10B VISIBLE RED 5-70MA @2V •.45

## RCA 2010

NUMITRON DIGITAL DISPLAY TUBE, INCANDESCENT FIVE VOLT SEVEN SEGMENT  
 .6" HIGH NUMERAL VISIBLE FROM 30 FEET  
 STANDARD NINE PIN BASE (SOLDERABLE)  
 LEFT HAND DECIMAL POINT  
 \$4.00 EACH

## CT500S

A SINGLE MOS CHIP WITH ALL THE LOGIC NECESSARY FOR A - TWELVE DIGIT - FOUR FUNCTION CALCULATOR WITH AN EXTRA STORAGE REGISTER FOR CONSTANT OR MEMORY APPLICATION  
 28 LEAD DIL PACKAGE  
 CAPABILITIES (+, -, x, \*)  
 CHAIN CALCULATIONS  
 TRUE CREDIT BALANCE  
 SIGN DISPLAY  
 AUTOMATIC KEYBOARD DEBOUNCE  
 SINGLE VOLTAGE SUPPLY IS POSSIBLE

COMPLETE WITH DATA.....\$14.95  
 DATA ONLY.....1.00  
 (REFUNDABLE WITH PURCHASE OF CHIP)

## SINGLE CHIP 40 PIN

ADD, SUBTRACT, MULTIPLY, AND DIVIDE  
 12 DIGIT DISPLAY AND CALCULATE  
 CHAIN CALCULATIONS  
 TRUE CREDIT BALANCE  
 SIGN OUTPUT  
 AUTOMATIC OVERFLOW INDICATION  
 FIXED DECIMAL POINT AT 0, 2, 3, OR 4  
 LEADING ZERO SUPPRESSION  
 DATA ONLY.....1.00  
 (REFUNDABLE WITH PURCHASE OF CHIP)  
 COMPLETE WITH DATA.....9.95

## 3 CHIP SET

EIGHT DIGIT  
 FLOATING DECIMAL  
 LEFT HAND ENTRY  
 WILL +, -, x, \*  
 OVERFLOW SIGNALS  
 COMPLETE WITH DATA.....8.95  
 DATA ONLY.....1.00  
 (REFUNDABLE WITH PURCHASE OF CHIP)

## NATIONAL MOS

DYNAMIC SHIFT REGISTERS TO-5  
 MMS02 DUAL 50 BIT 1.25  
 MMS06 DUAL 100 BIT 1.75  
 MMS06 DUAL 100 BIT 1.50  
 MMS03 100 BIT 2.25  
 MMS06 50 DIL 1.50  
 STATIC SHIFT REGISTERS  
 MMS04 DUAL 16 BIT 1.50  
 MMS05 DUAL 32 BIT 1.75  
 MMS00 DUAL DIFFERENTIAL ANALOG SWITCH P.50

## 7400dip

7400 .35  
 7400U TTL .50  
 7401 .35  
 74001 .50  
 7402 .35  
 7403 .35  
 7404 .35  
 74004 .50  
 7405 .35  
 74005 .50  
 74121 1.60  
 7413 1.15  
 7410 .25  
 7420 .35  
 74L20 .50  
 74H20 .50  
 74H22 .50  
 7430 .35  
 74L30 .50  
 7440 .35  
 74H40 .50  
 7441 1.60  
 7442 1.30  
 7446 1.75  
 7447 1.75  
 7448 1.15  
 7450 .35  
 7451 .35  
 74H51 .50  
 7453 .35  
 74H53 .50  
 7454 .35  
 74L54 .50  
 7460 .35  
 74L71 .30  
 7472 .50  
 74L72 .60  
 7473 .65  
 74L73 .90  
 7474 .65

7476 .70  
 7480 .65  
 7483 1.30  
 7486 .80  
 7489 3.50  
 7490 1.50  
 7491 1.15  
 7492 1.15  
 7493 1.15  
 7495 1.25  
 74L5 2.00  
 74307 .70  
 74353 2.00  
 74323 2.00  
 74393 1.50  
 74395 1.30

## CMOS

CD4001 .75  
 CD4002 .75  
 CD4012 .75  
 CD4023 .75

## LINEARS

LM100 1.00  
 LM309H 1.00  
 LM309K 2.00  
 NE555B 1.00  
 NE555B 1.00  
 707 1.00  
 709 .45  
 710 .50  
 711 .40  
 723 1.00

## LINEAR SPECIAL

TEN 741 FULLY COMPENSATED OP AMPS WITH DATA SHEETS  
 8-PIN DIP ONLY  
 TEN FOR \$3.75  
 EACH .40

T. I. H38  
 PHOTO D10E  
 \$1.50

## ZENER DIODES

1W  
 1N4651 3.9V  
 1N4735 6.2V  
 1N4740 10.0V  
 EACH .50

SEND FOR FREE FLYER!!

ALL IC'S-NEW AND FULLY TESTED-LEADS PLATED WITH GOLD OR SOLDER-ORDERS FOR \$5.00 OR MORE ARE SHIPPED PREPAID, SMALLER ORDERS - ADD 35¢. CALIFORNIA RESIDENTS ADD SALES TAX...IC'S SHIPPED WITHIN 24 HOURS

**BABYLON ELECTRONICS** P.O. BOX J  
 CARMICHAEL, CA. (916) 966-2111

# market center

## INVENTIONS & PATENTS

CASH-ROYALTIES for patented, unpatented inventions. GLOBAL MARKETING SERVICE, 2420-AF 77th, Oakland, Calif. 94605

## WANTED

QUICK cash for electronic equipment, components, unused tubes. Send list now! BARRY, 512 Broadway, New York, N.Y. 10012, 212 Walker 5-7000

TOP DOLLAR paid for ic's, mos, linear, ttl, dtl, no quantity too large, send list now or call collect at 212 431 7163 CASH WAITING

## ELECTRONICS ENGINEERING & INSTRUCTION

SHORTCUTS to success! Highly effective, profitable short courses. (75 choices). Study at home. Diploma awarded. Our 27th year. Free literature. CIEE-E, Box 10634, Jackson, Miss. 39209

LOGIC newsletter, design and construction, sample copy \$1.00. LOGIC NEWSLETTER, Box 252, Waldwick, N.J. 07463

## REBUILD YOUR OWN PICTURE TUBES?

With Lakeside Industries precision equipment, you can rebuild any picture tube!

For complete details, send name, address, zip code to:

LAKESIDE INDUSTRIES  
 3520 W. Fullerton Ave.  
 Chicago, Ill. 60647  
 Phone: 312-342-3399



## MOST VERSATILE Stereo Theatre TRUCK DEVELOPED!



Stair Climbing Dolly

## FURNITURE PADS



\$8.00 Each \$69.95 Set of 3 Pads



CONSOLE TV COVER \$24.95



YEATS PLATFORM DOLLY \$24.95

FREE illustrated brochure

YEATS dollies  
 1324 W. FOND DU LAC AVE.  
 MILWAUKEE, WIS. 53205

STANDARD MODEL No. 7 \$89.50

TV TUNER repairs-Complete course details, 12 repair tricks. Many plans. Two lessons, all for \$1. Refundable. FRANK BOCEK, Box 3236 (Enterprise), Redding, Calif. 96001

## FOR SALE

GUARANTEED metal detectors. Catalog. DETECTOR, Room 277-T, 102 W. Arrellaga, Santa Barbara, Calif. 93101

B & K, Sencore test equipment, discount prices. Free catalog and price sheet. FORDHAM RADIO, 558 Morris Avenue, Bronx, N.Y. 10451

SEMICONDUCTOR and parts catalog. J. & J. ELECTRONICS, Box 1437, Winnipeg, Manitoba, Canada

1973 hobby electronics directory. Parts, plans, kits surplus, and much more. \$1.50. NEWCAL, Box 323-C, El Segundo, Calif. 90245

FREE catalog lists resistors, tubes, transistors, rectifiers, condensers, tools, tuners, etc. etc. HYTRON HUDSON, Dept. RE 2201 Bergenline Ave., Union City, N.J. 07087

CANADIAN surplus catalog \$1.00. ETCO ELECTRONICS, 464B McGill, Montreal, Canada

## BUILD A "SPACE-AGE" TV CAMERA!

ONLY KNOWN SOLID-STATE CAMERA IN KIT FORM!  
 Also available factory assembled. Ideal for experiments, industry, education, etc. High quality performance tested by over seven years of lab and field testing. Fully guaranteed. Completely self-contained. Connects to any TV set without modification. Easy-to-follow assembly manual. Model XT-1A, Series D complete with vidicon \$145.00. \$20.00 elsewhere in USA & Canada (less vidicon tube \$116.95 pp.). Many other kits, parts and plans also available.

PHONE or WRITE for CATALOG...DIAL 402-987-3771  
 BOX 453-RE ATV Research DAKOTA CITY, NEBR. 68731

## HIGHLY PROFITABLE ONE-MAN ELECTRONIC FACTORY

Investment unnecessary, knowledge not required, sales handled by professionals. Ideal home business. Write today for facts! Postcard will do. Barta-DRE, Box 248, Walnut Creek, CA 94597.

## F.C.C. EXAM MANUAL

PASS FCC EXAMS! Memorize, study—1973 Tests-Answers for FCC First and Second class Radiotelephone Licenses. Newly revised multiple-choice questions and diagrams cover all areas tested in FCC exams—plus—Self-Study Ability Test! \$9.95 postpaid.

COMMAND PRODUCTIONS P.O. BOX 26348 — E  
 RADIO ENGINEERING DIVISION • SAN FRANCISCO, CALIF. 94126

### 3 "FANS ON A RACK"

Tri "prop" fans on a silver-gray relay rack panel (18"). Excellent for your "rig", darkroom or any type of electronic work. Even ideal for hobby projects. 200 CFM per fan. Each fan has 6" close mesh guard on each side. Reversible. 5000 rpm motor, has hp of 1/50. Operates on 115/160 cycles. Wt 7 lbs. By Howard Industries.

Only **\$12.00**  
2 for \$20

### NATIONAL EQUALS ON "DIGITAL CLOCK ON A CHIP"

Any "Chip" **\$12.88**

Mfrs #	Description	Price
5311	28-pin, ceramic, any readout, 6-digits A-B	\$12.88
5312	24-pin, ceramic, any readout, 4-digits C-D	\$12.88
5313	28-pin, ceramic, any readout, 6-digits A-B	\$12.88
5314	24-pin, plastic, LED and Incandescent readouts, 6-digits: A-B	\$12.88

Code: A—Hold Count. C—1 PPS Output.  
B—Output Strobe. D—BCD



\*Compare and Save!  
\*Money Back Guarantee!  
\*With Spec Sheet!

### 12-DIGIT "CALCULATOR CHIP" SALE

Similar to Mostek 5001. Outperforms Texas 8-digit TMS1802. A 40-pin DIP. Adds, multiplies, subtracts, and divides. Use with 7-segment readouts, Nixies, and LEDs. We include schematics, instructions to build calculator.

Only **\$12.88**  
3 for \$35  
CT5005 — Same as above with MEMORY — \$14.95

### GENERAL TELEPHONE DATA ENTRY KEYBOARD

Used in calculators, touch-tone, encoding, programming devices. 10 PUSH-BUTTONS (4 to 9). 2 uncommitted. All switches have 2 separate poles. 2 separate buses — totalling 6 buses & 24 poles... Any combination of which can be used! Size: 8x2 1/2 x 1 1/2"

Only **\$8.88**

### WORLD FAMOUS SEMI-KON Dollar Stretchers

- 5-MOS REGISTERS, 5013-17, mini dips, no-test
  - 1-2N3055 npn, 100W, 15A, TO-3, transistor
  - 5-ER900 TRIGGER DIODES for SCRs & Triacs
  - 2-FET'S 2N5457 N channel 6000 umhos, TO-92 plastic
  - 10-1N914 fast switch diodes, silicon, 4 nanoseconds
  - 2-8 AMPS, TO-18 PNP, Nixie driver IC, DIP
  - 40-1TT MICRO MINI RECTIFIERS silicon porcelain to 1KV
  - 30-WORLD'S SMALLEST RECT. & zeners, 1W, assorted volts
  - 4-2N4269 Nixie tube driver transistors 100V, npn
  - 2-PUTS, prog. uni-transistors, similar to GE-D13T
  - 2-2N3296, 2N3298, N channel, 6500 umho TO-18
  - 3-2N2646 unijunctions, plastic transistors, Texas
  - 5-2N107, GE, most commonly used pnp, germanium
  - 80-SILICON, glass rectifiers, computer, axial leads
  - 80-GERMANIUM, glass rectifiers, signal, axial leads
  - 6-2N5706, PNP, germanium, nfn, transistors, TO-22
  - 10-1 AMP 1000 PIV, epoxy, submini silicon rectifiers
  - 30-500MW ZENERS, axial, 4, 6, 9, 10, 12V rectifiers
  - 4-2N3055, HOBBY, 40W npn silicon transistors, TO-3
  - 30-3-AMP RECTIFIERS, silicon, epoxy, assorted V, axial
  - 5-2N7443, BCD-to-Nixie driver IC, DIP
  - 10-LINEAR AMPS, 709, 710, 711, 741, TO-3
  - 10-709 LINEAR AMPS, 741's too, DIP'S
  - 5-HOBBY MEMORY CELLS, SN7481, up to 16-cell, DIP
  - 2-2N5296 32-WATT NPN PLASTIC TRANSISTORS, for NE-540
  - 10-2N6108 40-WATT PNP PLASTIC TRANSISTORS, for NE-540
  - 10-RCA CA-3000 OP AMP, TO-5 case
  - 5-723 VOLTAGE REGULATORS, TO-5
  - 4-1000 HFE DARLINGTON Transistors, TO-18 case
  - 2-2N5036 100 WRF plastic trans 100 space-amp 85 watts
  - 4-2N5296 HOBBY, 35 watts, plastic powers, NPN
  - 4-2N6109 HOBBY, 40 watts, plastic powers, PNP
  - 5-PLASTIC 35W powers, nfn, silicon, hobby 2N6121
  - 5-PLASTIC 35W powers, pnp, silicon, hobby 2N6124
  - 2-MOS FETS, N channel, 10K umho 3N128, TO-18, RCA
  - 2-MOS FETS, DUAL GATE, N chan. 3N187, TO-18, RCA
  - 2-MOS FETS, DUAL GATE, N chan. 3N140, TO-18, RCA
  - 4-RCA 2N3600 PNP, UHF transistors, tv-fm, TO-18, 1000mc
  - 4-PHASE ADCK LOGS, hobby 565, 561
  - 10-MINI DIP phase lock loops 709, 741, 801, 307, hobby
  - 4-VOLTAGE REGULATORS, LM309K, hobby, TO-3
  - 1-300V PLASTIC POWER TAP transistors, 6W
  - 10-TO-5 Case 536, 540, 565, 567, 741
- \*Untested, guaranteed satisfaction

### HOT EXPERIMENTER SPECIALS BY POLY PAKS

- 1-5311-14 CLOCK ON A CHIP, 4-or-6 digit, 24-or-28 pin
- 1-CALCULATOR ON A CHIP, hobby, exp. 40-pin, specs
- 4-DECADE COUNTER, hobby special, SN7490, DIP pak
- 1-2516 CHARACTER GENERATORS, hobby, for MAN 2
- 10-LEDS, hobby or experimental quality, asst types
- 10-555 HOBBY TIMER special, in the mini DIP paks
- 10-NATIONAL 301 and 307 HOBBY OP AMP SPECIAL TO6
- 15-NATIONAL & SIGNETIC TTL dip special, all marked
- 10-SIGNETIC OP AMP, 531, 533, 536, 550, 555, DIPs, TO-5

### PHOTO TRANSISTORS, with darlington amp filter, lens

- 1- PHOTO TRANSISTOR, with darlington amp filter, lens \$1
- 2- PHOTO TRANSISTORS, with darlington amp, 2N5777, GE. \$1
- 4- PHOTO CELLS, Clairex, pancake, 30K-70 ohms \$1

### SUPER ECONOMY \$1 PARTS "DOLLAR STRETCHERS"

- 30-POWER RESISTORS, 8-to-25m, square, vitreous, asst. vals.
- 10-MICRO REED SWITCHES, 1" long, transistor work
- 1-\$25 SURPRISE PAK, resistors, caps, transistors, etc.
- 50-TERMINAL STRIPS, 1-to-8 screw & tie lugs
- 30-SQUARE DISCS, 85mmf, to 0.1M, 741, 801, 307, hobby
- 75-PRE-FORMED DISCS, capacitors, printed circuit
- 60-TUBE SOCKETS, receptacles, plugs, audio, etc.
- 100-PREFORMED RESISTORS, 1/2 watt, printed circuit
- 50-COILS & CHOKES, 1/2, 1, 2, 5, 10, 50 ohms, 1 meg, 5%
- 60-PRECISION RESISTORS, 1/4, 1/2, 1, 2, 5, 10, 50 ohms, 1 meg, 5%
- 60-TUBULAR CONDENSERS, to 5mf, to 1kv, molded too
- 30-POLYSTYRENE CONDS, finest caps made, asst. values
- 10-PANEL SWITCHES, 110VAC, micro, rotary, thermal, slide
- 10-VOLUME CONTROLS, to 1 meg, duals too, some w/switch
- 50-TRIMMER RESISTORS, 1/4, 1/2, 1, 2, 5, 10, 50 ohms, 1 meg, 5%
- 40-MICRO-MINI CONDENSERS, to 0.5mf ceramic
- 5-IBM COMPUTER BOARDS, trans, caps, res, coils, etc.
- 10-ELECTROLYTIC COND'S, FP's, & tubular, 2 & 3 sect. too
- 6-TRIMMER POTS, 100, 500, 2K, 5K, 10K, 25K, 1/2w, snap-in
- 6-MICRO-MINI RESISTORS, 1/4, 1/2, 1, 2, 5, 10, 50 ohms, 1 meg, 5%
- 30-YELLOW PACKET FILARS, assorted vals & sizes
- 10-POWER TRANSISTOR SOCKETS, for TO-3, asst. types
- 64-PLASTIC TRANSISTORS TO-18, printed circuit

### Lowest Prices Largest Selection TTL IC's

Brand New • "DIP" Packages Order by type number! Spec sheets on request • ONLY • Buy 3 or more, 10% discount

Type	Price	Type	Price	Type	Price	Type	Price
SN7400	\$0.30	SN7438	.60	SN7481	1.50	SN7414g	1.40
SN7401	.30	SN7440	.30	SN7482	.95	SN74151	1.25
SN7402	.30	SN7441	1.40	SN7483	1.50	SN74153	1.60
SN7403	.30	SN7442	1.25	SN7485	1.41	SN74154	2.10
SN7404	.35	SN7443	1.35	SN7486	.55	SN74155	1.55
SN7405	.32	SN7444	1.35	SN7489	3.75	SN74156	1.55
SN7406	.55	SN7445	1.35	SN7490	1.50	SN74157	1.55
SN7407	.55	SN7446	1.65	SN7491	1.50	SN74158	1.55
SN7408	.55	SN7447	1.65	SN7492	1.10	SN74160	1.95
SN7409	.35	SN7448	1.50	SN7493	1.10	SN74161	1.95
SN7410	.30	SN7451	.35	SN7494	1.10	SN74162	1.95
SN7411	.35	SN7453	.35	SN7495	1.10	SN74163	1.95
SN7413	.95	SN7454	.50	SN7498	1.10	SN74164	3.50
SN7415	.85	SN7455	.35	SN7499	1.10	SN74165	3.50
SN7416	.55	SN7460	.35	SN7400	1.49	SN74180	1.20
SN7417	.55	SN7464	.50	SN74104	.55	SN74181	4.50
SN7420	.30	SN7465	.50	SN74107	.60	SN74182	1.20
SN7421	.35	SN7470	.50	SN74108	1.25	SN74184	2.50
SN7422	.35	SN7472	.50	SN74112	1.25	SN74185	2.50
SN7426	.35	SN7473	.65	SN74113	1.25	SN74192	1.95
SN7430	.30	SN7474	.65	SN74114	1.25	SN74193	1.95
SN7432	.30	SN7475	1.30	SN74121	.70	SN74194	1.95
SN7437	.60	SN7476	.75	SN74122	.75	SN74195	1.35
		SN7478	.95	SN74123	1.20	SN74199	2.65
		SN7480	.75	SN74140	.50	SN74200	9.99

• Factory Marked!

Designed by our Scientific Device engineers as the most advanced digital timing device in the consumer "time" field. One radio-and-TV station engineer tells us, "Not a change of a second in 3 months." It is so accurate we use it as our standard. KRONOS KR100 Series, in the new sleek all-purpose walnut-and-black modern design cabinet, enhances any office, home, den, etc. It becomes a "visible-atomic conversation piece" wherever it is placed. Has modern LSI National Clock Chip, and 8-page brochure chock-full with pictorials and easy-to-understand, step-by-step instructions. This kit is COMPUTER SIMPLIFIED making do-it-yourself easy! Other features include 3 setting controls, 1 hour per second, 1 minute per second, and hold button. Easy-to-change from 12 to 2420s, 4 to 6 digits, 50 to 60 Hz operation. Your choice of different type readout systems: MAN-3 Type LED, MAN-1 Type LED (the larger character size), MAN 4 Type LED, 7-Segment Nixie Type Tubes. Kit includes POLAROID filter.

### KRONOS \$47.

With Cabinet

### 'TIME STANDARD' CHRONOMETER

- KR101 7-Segment MAN-3 Type LED, 6 Digits \$47.00
- KR102 7-Segment MAN-1 Type LED, 6 Digits \$69.95
- KR103 7-Segment MAN-4 Type LED, 6 Digits \$57.00
- KR104 7-Segment Nixie Type Tubes Buy 3 — Take 10% \$47.00

### WIRED ADD \$19.95

Size of cabinet: 6" x 3 1/2" x 8" deep

### PHILCO 11 TRANSISTOR AM RADIO CHASSIS

Use as:  
• Mike amplifier  
• Phono amplifier  
• Tape amplifier

Only **\$5.95**

One of the most versatile AM Radio and multi-purpose amplifiers we have seen at Poly Paks famous "Economy" price. Measures only 4 1/2" x 3" x 2" high. With tuning capacitor, IF circuitry, loopstick, ant., volume control with switch, AC and phono-mike jacks. Separate switch for changing from AM radio to amplifier. Uses either 110V plug-in adapter (not with unit) and a 9-volt battery power. Exceptional sensitivity and power. Feeds into 16 ohm speaker. Complete with spec sheets, diagrams, and hookup ideas. AC or DC

Shpg. wt. 1-lb.

### AC-DC CHARGER-CONVERTER

Only **\$1.98**

Converts 11-and-8-transistor chassis from 9VDC to 110VAC. Easy to hook in, with instructions. Size: 2" x 1 1/4" x 1 1/4". 1-lb. 5-ounce ceramic, cylindrical magnet. Twin voice coil, 4 and 8 ohms. 50-16,000 cycles. Shpg. wt. 3 ins. Only 5-IN. "HI-FI" PM SPEAKER **\$1.98**

### 8 TRANSISTOR AMPLIFIER CHASSIS

Only **\$3.95**

Same as above, except no AM radio section. Completely wired! With built-in preamp, mike, phono and tape inputs. Color-coded wires with diagram and hookups. Works off 9VDC transistor battery. Excellent fidelity.

### LINEAR Op Amps

FACTORY GUARANTEED

- 531 Hi slow rate op-amp (TO-5) \$2.50
- 532 Micro power 741 (TO-5) 2.50
- 533 Micro power 709 (TO-5) 2.50
- 536 FET input op amp (TO-5) 3.95
- 837 Precision 741 (TO-5) 2.50
- 840 70W pwr driver amp (TO-5) 2.04
- 850 Precision 723 voltage reg. (DIP) 1.17
- 855 Timer 2 uSeconds to 1-hr (A) 1.00
- 858 741C Times faster than 741C 2.49
- 859 Dual 741 (mini DIP) .88
- 860 Phase lock loops (DIP) 3.25
- 861 Phase lock loops (DIP) 3.25
- 862 Phase lock loops (DIP) 3.25
- 865 Phase lock loops (A) 3.25
- 866 Junction generator (A) 3.25
- 867 Tone generator (A) 3.25
- 898 Four quadrant multiplier 3.10
- 702C HI-grain, DC amp (TO-5) .44
- 703C RF-IF, amp, 14 ckts (TO-5) 1.00
- 709C Operational amp (A) .49
- 709CV Op amp (mini DIP) .49
- 710C Differential amp (A) .44
- 711C Dual diff. comp (A) .44
- 723C Voltage regulator (A) .88
- 741C Frequency comp 709 (A) .49
- 741CV Freq. comp 709 (Mini DIP) .49
- 747C Dual 741C (A) 1.25
- 748C Freq. adj. 741C (A) .44
- 748CV Freq. adj. 741C (mini DIP) .49
- 709-709 Dual 709C (DIP) 1.00
- 739-739 Dual stereo preamp 1.98
- 741-741 Dual 741C (A) 1.00
- 78450 Dual peripheral driver (DIP) .69

(A) TO-5 or DIP dual in line pak

### NATIONAL 'OP' AMPS

BUY ANY 3 — TAKE 10%

Type	Description	Price
LM-300	Super 723 V. reg.	\$1.49
LM-301	Hi-performance amp	.49
LM-302	Voltage follower	1.49
LM-304	Pos. V. reg.	1.49
LM-307	Super 741	1.49
LM-308	Super gain op amp	.59
LM-309A	SV 200 mil V. reg.	1.50
LM-309K	SV 1-amp V. reg.	2.25
LM-320	Comparator	1.50
LM-321	Minus 1-amp V.R.	2.95
LM-320	Minus 12V 1-amp V.R.	2.95
LM-320	Minus 15V 1-amp V.R.	2.95
LM-350	Dual peripheral driver	.59
LM-371	AGC squelch op amp	1.49
LM-371	R-F I-F op amp	.69
LM-373	AM, FM, SSB, I-F audio	3.75
LM-380	2-watt audio amplifier	1.98

TO-3 case, others TO-5

### GENERAL ELECTRIC 3-WATT AUDIO AMP

3 FOR \$6.00

Delivers 3 watts continuous, 10 watts peak. With heat sinks: micro-mini size: 3/4" x 1/2" x 9/16". 9 to 30V supply. High sensitivity. 8 to 16 ohms. For mono and stereo phonos, tape, FM, AM, TV, servo.

### "How's Your MEMORIES For 1973?"

- 1101 256 Bit RAM MOS \$3.50
- 1103 1024 Bit RAM MOS 8.50
- 2513 Character Gen. ROM 12.50
- 2516 Character Gen. ROM 12.50
- 8223 64 Bit RAM TTL 3.50
- 8223 Programmable ROM 7.95
- MEM260 1024 Bit RAM 6.88

### INTEGRATED CIRCUIT SOCKETS

Buy Any 3 — Take 10% Discount!

- 14-Pin, dual in line \$1.45
- 16-Pin, dual in line .50
- TO-5, 8 or 10 pins .29

### WIRE-WRAP INTEGRATED CIRCUIT SOCKETS

14-Pin \$1.45  
16-Pin \$1.45  
2 for \$1.

### 35 WATT AUDIO AMPLIFIER BASIC

Only **\$3.33** 2 FOR \$6.66

For Class AB use. Basic includes: Signetec 6-40 90 ohm resistor, high power driver TO-5 'IC' with a pair of complimentary 85-watt plastic transistors, i.e. 2N6296 npn and 2N6109 pnp. With schematics, printed circuit and parts board layouts.

Terms ad postage. Phone Orders: Wakefield, Mass. (617) 245-8829 Retail: 18-18 Del Carmine St., Wakefield, Mass. (off Water Street) C.O.D.'S MAY BE PHONED

15¢ CATALOG on Fiber Optics, 'IC's, Semi's, Parts

### POLY PAKS

P.O. BOX 942R, LYNNFIELD, MASS. 01940

**CANADIAN'S** free catalog LED's, I.C.'s, transistors, SCR's, diodes, parts. **CORONET ELECTRONICS**, 720 Notre Dame St. W., Montreal, Canada

**BEAUTIFUL** catalog. Free! Professional Line of Guaranteed Metal Detectors. Find Coins, Jewelry, Relics. **FISHER**, Room 727-Q, Box 490, Belmont, Calif. 94002

**EXPERIMENTERS** only use my used parts. Save money. Capacitors, resistors, transistors IC's. List 25¢. **TED HOLDER**, 502 Pacific Drive, Belton, Mo. 64012

**FREE** Bargain Catalog. Transistors, Computer Boards, LEDs, Thermocouples, Parts. **CHANEY'S**, Box 15431, Lakewood, Colorado 80215

**NEW** Instruments oscilloscope from \$79.00. Signal generator \$39.00. Multimeter for inductance, voltage, current, and capacitors from \$14.00. For catalogue send \$1.00 to: **TELE-MIX**, Box 75, 17522 Jaerfaella, Sweden.

**TUNER** service UHF or VHF \$9.75, combo \$15.00. Includes all parts except tubes, transistors, diodes, nuvistors. Tuners repaired, realigned and neutralized by expert technicians. Send to **RAINBOW TUNER LABS.**, 4158 Greeby St., Philadelphia, Pa. 19135

**INTEGRATED CIRCUIT BREADBOARD SYSTEM**



Included is one 4 1/2" x 7 1/2" etched glass epoxy board which will mount up to 8 I.C.'s in sockets or soldered from either side.

Also over 600 cardstock lay-overs are included, each 5/8" x 1 1/4", showing pin connections for most of the 7400 series, top or bottom mounted. Each solder pad will accept 3-5 wires or discrete components.

Board undrilled. Send \$4.95 plus postage for 7 or. (18¢). Calif. res. add sales tax.

Sollie Enterprises, Box 41283  
Los Angeles, California 90041

**I.C. AND TRANSISTOR SPECIAL.** DCL EQUIVALENTS OF 7400, 7403, 7412, 7420, 7440, 7450, 7460, 22¢; 7474, 7470, 30¢. **ADJUSTABLE VOLTAGE REGULATORS** (MFC6034A) 75¢. 30V/100MA/300 MHZ NPN TRANSISTORS 5/\$1.00. ALL FULLY GUARANTEED. MINIMUM ORDER \$3.00. **NEMOS ELECTRONICS** P.O. BOX 116, SAUGUS, CALIF. 91350

**DIGITAL electronics!** Complete schematics, parts lists, theories—Discrete Component Digital Clock, \$3.00—Sound Sensitive Switch, \$1.50. Increase technical competence, hobby skills—Complete course in Digital Electronics is highly effective, \$10.00. Free literature. **DY-NASIGN**, Box 60R2, Wayland, Mass. 01778

**FREE CATALOG**—Tremendous electronics bargains. **Pacific**, Box 4188T, Mountain View, Calif., 94040.

**SURPLUS, NEW, USED; SEMICONDUCTOR, I.C.'s, (LINEAR, DIGITAL), OPTOELECTRONICS, P.C. BOARDS, TRANSFORMERS, HDWR. FREE FLYER. ELECTRONIC DISCOUNT SALES**, 138 N. 81st STREET, MESA ARIZ. 85207

**Technical Excellence in Electronics.**

On our small, friendly campus the emphasis is on Living as well as Learning. Extra-curricular social activities, student clubs, a student operated radio station, student government, new dormitory and a full sports program help provide a world of your own in which to prepare for tomorrow. Associate Degree in Engineering Electronics. B.S. obtainable. G.I. approved.

**VALPARAISO TECHNICAL INSTITUTE**  
Dept. C, Yellowstone Trail, Valparaiso, Indiana 46383

**CLASSIFIED COMMERCIAL RATE** (for firms or individuals offering commercial products or services). \$1.00 per word . . . minimum 10 words.  
**NONCOMMERCIAL RATE** (for individuals who want to buy or sell personal items) 70¢ per word . . . no minimum.  
**FIRST WORD and NAME** set in bold caps at no extra charge. Additional bold face at 10¢ per word. Payment must accompany all ads except those placed by accredited advertising agencies. 10% discount on 12 consecutive insertions, if paid in advance. Misleading or objectionable ads not accepted. Copy for September issue must reach us before July 1.

**CLASSIFIED ADVERTISING ORDER FORM**

1	2	3	4	5
6	7	8	9	10
11	12	13	14	15
16	17	18	19	20
21	22	23	24	25
26	27	28	29	30
31	32	33	34	35

No. of Words { @ .70 Non-Commercial Rates } = \$  
 { @ \$1.00 Commercial Rate } = \$  
 No. of Words in bold face @ .10 = \$

Total Enclosed \$ \$

Insert \_\_\_\_\_ time(s)

Starting with \_\_\_\_\_ issue

NAME \_\_\_\_\_

ADDRESS \_\_\_\_\_

CITY \_\_\_\_\_ STATE \_\_\_\_\_ ZIP \_\_\_\_\_

SIGNATURE \_\_\_\_\_

MAIL TO: RADIO-ELECTRONICS, CLASSIFIED AD DEPT., 200 PARK AVE. SOUTH, NEW YORK, N.Y. 10003

Payment must accompany order unless placed through accredited advertising agency 28

**15 AMP CHARGER KIT**

Brand new GE transformer with solid state rectifier. Assembled in minutes and ready to charge any 12 volt battery up to 15 amps. — #PK-4 \$7.50

**POWER AMP TRANSFORMER**

115 VAC input. Output 70 VCT at 3 amps. Makes a magnificent power amp.

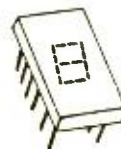

- #73S-43 \$7.50
- 7 Segment LED display, similar to MAN-1 \$3.50
- 7 Segment LED display, similar to MAN-3 2.00
- 7 Segment LED display, similar to MAN-4 3.50
- LED (red) 3 for \$1.00 \*\*
- LM 309K \$2.00

- PA234 1 watt audio amp \$1.25
- PA264 5 watt up to 25 volt regulator 1.25
- PA265 5 watt up to 37 volt regulator 1.50
- GE THYRECTOR 20 amp peak, 30 volt surge protector 5/\$1.00
- 709 OP AMP TO-5 3/\$1.00
- DUAL 709 OP AMP .75

**HOW'S YOUR MEMORY**

- RCA MEMORY STACK ultra compact 32x32x9 \$50.00
- MEMORY STACK 32x32x16x9 frames 100.00
- SINGLE PLANE 64x64 10.00
- SINGLE PLANE 32x32x16 15.00

**AM-FM RADIO \$5.50**

Fully built, with AC supply, no cabinet, no speaker. Send for free catalog. Postage extra on above items.

**MESHNA PO Bx 62,**  
E. Lynn, Mass. 01904

Circle 79 on reader service card

**JAPANESE TRANSISTORS**, Wholesale prices, Free catalog. **West Pacific Electronics**, Box 25837, W. Los Angeles, Calif. 90025

**TTL IC Semiconductor**, Parts Discount Price List. 10¢ TOTELEK, Box 222, Goodyear, Ariz. 85338

**SAM'S PHOTOFACT**—841 Sets with Cabinets. \$895. **Tommy Douglas**, Route #3, Franklin, TN. 37064.

**SALES DIGITAL CLOCKS PHOTO TIMERS** **ASTRO LABS, BOX 524, MESA, ARIZ**

**75%-80% Discount.** Surplus Receiving Industrial Military Obsolete Free List **A&G ELECTRONICS** 10062 Cunningham, Westminster, Calif. 92686

**PLANS & KITS**

**FREE** catalog. Most unusual electronic kits available. Music accessories, Surf, Wind Synthesizers, Wind Chimes, many others. **PAIA ELECTRONICS**, Box B14359, Oklahoma City, Okla. 73114.

**CONVERT** any television to sensitive big-screen oscilloscope. Only minor changes required. No electronic experience necessary. Illustrated plans \$2.00. **RELCO**—A25, Box 10563, Houston, Tex. 77018

**COLOR ORGAN, METERS, PARTS. CATALOG. WORKSHOP**, Box 393RE, Bethpage, N.Y. 11714

COMPUTERIZED football easy to build realistic plans \$2.00. **JERRY JARVIS**, 921 East 19th, Spokane, Wash. 99203

DIGITAL IC MANUAL—1973 EDITION—1500 TYPES. DOUBLE LISTING BY TYPE AND WIRING DIAGRAM NUMBER. MANY CROSS-REFERENCED \$3.95. **ELECTRONETICS**, Box 278, Cranbury, N.J. 08512

BUILD 32-FUNCTION DIGITAL COMPUTER 24-PIN IC, 12 TRANSISTORS, COMPLETE INSTRUCTIONS, \$15.25. **ELECTRONETICS**, Box 278, Cranbury, N.J. 08512

TEN KNOB OCTAVE BAND GRAPHIC EQUALIZER plans-\$2.50. RECORD TELEPHONE CONVERSATIONS AUTOMATICALLY. Leave recorder UNATTENDED Plans-\$2.50. Both plans-\$4.00. **GREEN BANK SCIENTIFIC**, Box 100S, Green Bank, W. Va. 24944

ELECTRONIC BRAKE Instantly stops any AC motor. Full speed to dead stop in less than one revolution. Ideal for the drill press, lathe, saw, etc. Plans plus PC board \$10.00. Plans only \$2.50. **K.R. JOHNSON CO.**, 12000 Old Georgetown Rd., Rockville, Md. 20852

"DIGITAL SPEEDOMETER with numeric read-out Plans \$7.50 **KIMTRON**, Box 80134, Chamblee, Ga. 30341"

ELECTRONIC organ kits, keyboards and many components. Independent and divider tone generators. All diode keying. I.C. circuitry. With our kits you can build any type or size organ desired. 25¢ for catalog. **DEVTRONIX ORGAN PRODUCTS**, Dept. B, 5872 Ampala Dr., San Jose, Calif. 95129

FOUR TRACE SCOPE ADAPTER PLANS! **TITUS**, Box 242, Blacksburg, Va. 24060

### TUBES

RADIO & TV tubes 36¢ each. One year guaranteed. Plus many unusual electronic bargains. Free catalog. **CORNELL**, 4217-E University, San Diego, Calif. 92105

SAVE money on parts and transmitting-receiving tubes, foreign-domestic. Send 25¢ for Giant Catalog. Refunded first order. **UNITED RADIO COMPANY**, 56-R Ferry Street, Newark, N.J. 07105

RECEIVING & industrial tubes, transistors. All brands-biggest discounts. Technicians, hobbyists, experimenters—request free giant catalog and save! **ZALYTRON**, 469 Jericho Turnpike, Mineola, N.Y. 11501

### TAPE & RECORDERS

RENT 4-track open reel tapes—all major labels—3,000 different—free brochure **STEREO-PARTI**, 55 St. James Drive, Santa Rosa, Calif. 95401

**A NEW INSTRUMENT TO USE WITH YOUR SCOPE**

**MULTITRACER**

Use with your present Oscilloscope to trace Resistors, Capacitors, Transformers, Diodes, Transistors, Zeners, Triodes, most Semiconductor IC's, etc. Also shows continuity, in-circuit and go/no-go checks. Complete with diagrams and instructions. No internal scope connections. For medium or small production runs or for hobbyist, experimenter, engineer, or ham.

ONLY \$19.95—CHECK OR MONEY ORDER WHY PAY MORE!

BOX 14, LESCO ELECTRONICS, SKOKIE, ILL. 60076

# Opto Electronics Sale

LIGHT EMITTING DIODE GaAs INDICATORS



<input type="checkbox"/> 1-MV2*, TO-18, Dome, green, visible	\$1.19
<input type="checkbox"/> 1-MV4*, stud, high power, red, 2-watts	3.95
<input type="checkbox"/> 1-MV4M*, stud, high power, hi-dome, red, 2-watts	2.95
<input type="checkbox"/> 2-MV10*, TO-18, clear, diffused dome, red	1.00
<input type="checkbox"/> 2-MV50*, axial leads, micro-mini dome, clear, red	1.00
<input type="checkbox"/> 2-MV5022*, jumbo red dome, TO-18, visible	1.19
<input type="checkbox"/> 2-MV5020*, jumbo clear dome, TO-18, visible, red	1.19
<input type="checkbox"/> 1-MV5040*, 4-LED red array, with 6-lead pak	1.49
<input type="checkbox"/> 2-MV5080*, TO-18, micro-mini, clear dome, red	1.00
<input type="checkbox"/> 1-MV5222*, jumbo dome, green, panel snap-in	1.98
<input type="checkbox"/> 1-MV5322*, jumbo dome, GaAsp, panel snap-in	1.98
<input type="checkbox"/> 1-MV9000*, cartridge panel lamp, sealed, red, clear lens	1.49
<input type="checkbox"/> 2-MT-2*, Photo Transistor, light sensor, TO-18	1.00
<input type="checkbox"/> 1-ME-1*, infra-red, parabolic lens, pin type	1.19
<input type="checkbox"/> 2-ME-4*, infra-red, "invisible", TO-18, diff. dome	1.19
<input type="checkbox"/> 2-ME60*, infra-red, "invisible", axial, micro-mini	1.00
<input type="checkbox"/> 3-LED HOBBY SPECIAL, ass't. types, axial, TO-18, etc.	1.00
<input type="checkbox"/> 1-LED MAN-4*, hobby special, readout, 14-pin	1.49
<input type="checkbox"/> 1-LED MAN-3*, hobby special, readout, "the claw"	1.19

\* Monsanto LED equivalents.

### LED MITY DIGITS "DCM'S"

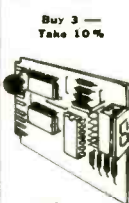

Buy 3 — Take 10%

Will outperform any other DCM on the market today. Not gaseous, not incandescent, but a device that will READ almost for life. MAN-4, Monsanto equal.

**9.99** Digital Counting Modules

INCLUDES P.C. EDGE CONNECTOR — FREE!

Kit includes: 3 x 2" printed ckt board, with fingers tool Side-mounting socket, MAN-4 resistors, 7448, 7475, 7490, booklet.

Only Poly Paks can do it!

### OPTO-COUPLERS

MCA2-30* 1500V Photo Darlington Relay	\$1.49
MCD1* 4000V Isolation Photo Transistor	4.95
MCD2* 1500V Isolation Photo Diode	1.29
MCT1* 4000V Isolation Photo Transistor	4.95
MCT2* 1500V Isolation Photo Transistor	1.49
MCT2-D* 1500V Isolation Twin Photo Transistor	1.98
MCT5-10* 10,000V Isolation Photo Transistor	4.95
MCT5-25* 25,000V Isolation Photo Transistor	5.95

\*Monsanto Equivalent

**LITRONIX** Buy 3 — Take 10%

**FDL-7 LED 7-SEG READOUT** Pin-for-pin substitute for famous MAN-1. Electrically the same. Snaps into 14-pin DIP socket. Requires same drivers, i.e., SN7446 or SN7447. Requires 5V @ 20 mls per segment. 0.27 size character with left decimal. Size: 3/4 x 7/16 x 3/16".

**\$4.95**

**LED 7-SEGMENT READOUTS** Only \$3.95

0-9 plus letters, for SN-7448. Snaps in 14-pin DIP socket. 3/4" x 1/4" x 3/16". 5V 10ma, with decimal point. Like MAN-1

Socket for above, 50¢

**MAN-4 EQUAL**

**LED READOUTS** Buy 3 — Take 10%

This display is excellent for small portable electronics, such as DVM's, calculators, etc. Equivalent to Monsanto MAN-3A. Operates from 5V, 20 milliamps, with 47 ohm dropping resistor.

**\$2.95**

**6-DIGIT MAN-3A MUX'D PC BOARD**

Clock DCMs, VTVM, DVM, calculators, multiplexed.

6-MAN-3A's for above board, \$15

**\$2.95**

**EPOXY FULL WAVE SILICON BRIDGE RECTIFIERS**

PIV	2 Amp	6 Amp
100	\$5.99	\$8.99
150	.75	.95
200	.95	1.25
400	1.19	1.50
600	1.35	1.75
800	1.59	1.95
1000	1.79	2.25

Code: 2 amp TO-5 case  
6 Amp 1/2 x 1/2 x 3/16 sq

**ALLEN BRADLEY 'TRANSISTOR' POTS** Any 4 for \$1

Type F Screwdriver adjust.

Ohms	7.5K
75	10.0K
100	20.0K
200	25.0K
250	50.0K
500	75.0K
750	100K
1.0K	250K
2.5K	2 Meg
5.0K	5 Meg

**ALLEN BRADLEY 'MICRO-POTS'** 2 for \$1

Type G, 1/2" dia, x 1/2" high. Mounts 1/16" hole, with shaft, linear, immersion-proof high freq.

Ohms	2.5K	25.0K
75	5.0K	75.0K
100	7.5K	100.0K
200	10.0K	5 Meg
500	20.0K	

We stock Locknut Bushing & Screwdriver types at same low prices.

**Potter & Brumfield KAP RELAYS**

Your choice 3 for \$7.50 **\$2.98**

115 VAC 3PDT	\$2.98
12 VDC 3PDT	2.98

Excellent for "HAM" use as antenna switching, latching transmit, receive, etc., and 100's of commercial or industrial uses. Includes plastic dust-cover with diagram and hookup info, 11-pin plug-in base. Contacts movable gold flashed silver, stationary overlay, with silver cadmium oxide movables. All contacts 10 amp 3PDT. Coil data: 116VAC 2250 ohms, 17.5 ma, 12 VDC 21 ma, 16.8 ohms. Size: 2 3/4" x 1 5/16" Wt. 4 ozs. Center pin missing. Comar Mfg. type equal too.

Retail: 16-18 Del Carmine St., Wakefield, Mass.

Terms: add postage Rated: net 30  
Phone Orders: Wakefield, Mass. (617) 245-3429  
C.O.D.'S MAY BE PHONED IN  
P.O. BOX 942 R  
Lyndfield, Mass. 01940

**POLY PAKS**

Circle 74 on reader service card

## AM-FM-Stereo-Mux

### SOUND CONTROL CENTER

**ALL 3 PIECES** Only **29.95** **HYBRID**

**LOOK!**

Slide rule tuning!

FM freq: 88 to 108 mc! AM: 550 to 1600 kcal

**AM, FM Tuner**

**FM-Multiplex**

**Amplifier**

- FEATURES**
- AM, FM, FM-Multiplex stereo phono input!
  - Separate Tuner! Amplifier! and Multiplex!
  - FM Tuner has automatic frequency control!
  - Hybrid tube, transistor printed circuitry!
  - Separate volume and power control!
  - Separate bass and treble control!
  - Remote speaker control!
  - Connects easily to record changer!
  - Mike, tape, phono input!
  - Push-pull power output solid state!

Shpg. wt. for 3-pc. Sound Control Center — 10 lbs.

This is a Poly Pak exclusive. Bought for the economy-minded hi-fies. This unique audio system was designed for \$300 consoles. 15 watts of stereo music power. 3 separate units, each unit professionally designed by U.S.A. engineers. AM-FM tuner, Multiplex, push-pull TO-66 power transistors mounted on chassis. Outputs connect to any good speaker system. Voice coils of 8 connect to 16 ohms. Unique switch on panel connects external stereo speakers to other parts of rooms, home or office. Concentric volume controls for perfect stereo balance. Has built-in preamplifier, built-in AM antenna. 13"x8"x8"

**TUNER — 13" x 6" x 8"**

Tuner uses 12C9 for FM r-f amplifier and converter, 12BA6 for 1st FM i-f amp and AM i-f amp, 12BA6 for 12AX7 multiple preamp and AM detector, 12BE6 AM converter for hi-fi and TV. Built-in AFC. Comes complete with 8-pg. 8 1/2"x11" factory booklet, check-full of diagrams, printed circuit layouts of all parts, etc. All parts are easily identified. Power consumption 115 VAC 60 cy. Complete with all interconnecting cables. Wide frequency response. Includes printed front panel template. **WHERE CAN YOU GET SO MUCH AM! FM! STEREO! FOR SO LITTLE MONEY?**

**MULTIPLY — 4" x 6" x 3"**

Multiplex uses 12AT7 amp-doubler, 12AX7 38 kc output amp, with availability of "STEREO STATION INDICATING" lamp.

**POWER AMPLIFIER CHASSIS — 12" x 8" x 2"**

Solid state devices, using a pair of driver transistors to push-pull TO-66 "Sound Control Center" power.

**LOWEST PRICES EPOXY SILICON RECTIFIERS** \*microminature

PIV	2amp	2amp	3amp
50	\$2.05	\$2.05	\$2.08
100	.06	.06	.12
200	.09	.07	.15
400	.09	.09	.22
600	.12	.12	.28
800	.15	.15	.39
1000	.18	.18	.45

**STUD 'TRIACS'**

PRV	15 amp	25 amp
50	\$1.65	\$1.85
100	1.25	1.05
200	1.25	1.45
300	1.45	1.65
400	1.85	1.95
500	2.85	2.25
600		2.65

# LOGIC NEWSLETTER

SAMPLE COPY \$1.00  
LOGIC NEWSLETTER  
POB 252  
WALDWICK,N.J. 07463



The American Red Cross

## BUSINESS OPPORTUNITIES

**START small, highly profitable electronic production in your basement.** Investment, knowledge unnecessary. Postcard brings facts. **BARTA-REI**, Box 248, Walnut Creek, Calif. 94597

**TECHNICIANS desperately needed,** Employers Directory \$2. **CALEIS**, Box 514, Agnew, Calif. 95054

### DID YOU MISS

High-fidelity amplifier testing is not the easiest task. There are eight different tests you should make if you want to completely check out an amplifier. For full details on what these tests are and how to perform them, turn back to page 37

## ADVERTISING INDEX

**RADIO ELECTRONICS** does not assume responsibility for any errors which may appear in the index below.

READER SERVICE CARD NO.	PAGE
30	Bell & Howell Schools.....18-21
66	B & K Division of Dynascan Corp...Cover II
	Brooks Radio & TV Corp..... 89
71	Castle TV Tuner Services, Inc..... Cover IV
21	Channelock Inc..... 79
20	Cleveland Institute of Electronics.....72-75
	CREI, Division of the McGraw-Hill Continuing Education Co.....62-65
5	Crown International..... 14
12	Delta Products, Inc..... 61
70	Edmund Scientific..... 98
63	EICO, Electronic Instruments Co..... 86
61	Electronic Chemical..... 85
	EMC, Electronic Measurements Corp..... 71
7	Electro-Voice, Inc..... 16
18	E & L Instruments Inc..... 70
62	Fordham Radio Supply Co..... 85
	Grantham School of Engineering..... 59
	GTE Sylvania Electronics Components... 2
100	Heath Co.....Cover III
1	ICS School of Electronics..... 1
26	Indiana Home Study Institute..... 84
11	International Crystal Mfg. Co..... 60
9	International Electronics Unlimited..... 22
4	Jerrold Electronics..... 13
67	Linear Digital Systems Corp..... 90
14	Michelin International..... 66
29	Midwest HI-FI..... 85
6	Micro- Instrumentation Telemetry Systems, Inc..... 15
28	Mountain West Alarm Supply Co..... 83
27	National Camera Co..... 84
	National Radio Institute.....8-11
	National Technical Schools.....28-31
25	Oneida Electronics Mfg. Co. Inc..... 83
16	PTS Electronics, Inc..... 68
19	PLC Electronics..... 71
69	Quietrol Co..... 91
15	RCA Sales Corp..... 67
	RCA Electronics Components Semiconductors.....76-77
65	Rye Industries, Inc..... 88
3	Sansui..... 7
17	Schober Organ..... 69
68	Services Data Co..... 90
8	Southwest Technical Products..... 17
64	Sprague..... 87
23	Telematic..... 81
13	Tri-Star Corp..... 66
2	Tuner Service Corp..... 5
22	TV Tech Aids..... 80
	M. Weinschenker Elec..... 91
24	Xcelite Inc..... 82
	Zenith Radio Corp.....26-27
<b>MARKET CENTER</b>	
	ATV Research Corp..... 92
72	Babylon Electronics..... 92
	Barta..... 92
	Command Productions..... 92
75	Digi-Key..... 97
81	Delta Electronics..... 97
78	JTM Associates..... 97
	Lakeside Industries..... 92
	Logic Newsletters..... 96
	Lesco Electronics..... 95
79	Meshna Electronics, John Jr..... 94
73	Polypaks..... 93
74	Polypaks..... 95
	Solid State Sales..... 96
	Sollee Enterprises..... 94
	Yeats Appliance Dolly Sales Co..... 92
<b>SCHOOL DIRECTORY</b>	
	Valparaiso Technical Institute..... 94

**HC2000-7** amp all purpose silicon amplifier, 30MC bandwidth at 60W. These units are used for servo amps, power audio amps, power oper. amps \$22.95

**MULTI-TURN TRIM POTS**  
Similar to Bourns 3010 style  
3/16" x 5/8" x 1 1/4"  
50, 100, 500, 2000, 5000,  
10,000 and 20,000 ohms.  
\$2.00 3/\$5.50

**PRINTED CIRCUIT BOARD**  
4 1/2"x6 1/2" double sided fiberglass board, 1/16" thick, unetched \$1.60 ea. 5/\$2.50

**NIXIE TUBES**  
Similar to Raytheon 8754 tubes, with socket & data sheet \$2.25 3/\$6.00

TIS 73 N FET \$1.75  
2N4891 UJT \$1.50

**VERIPAX PC BOARD**  
This board is a 1/16" single sided paper epoxy board, 4 1/2"x6 1/2" (standard veripax), DRILLED and ETCHED which will hold up to 21 single 14 pin IC's or 8, 16 or LSI DIP IC's with busses for power supply connections. It is also etched for a 22 pin connector \$5.25

**ER900 TRIGGER DIODES.** These bidirectional trigger diodes are one of the best and cheapest methods to trigger SCR's and triacs...4/\$1.00  
FLV 100 Visible LED \$1.65  
ME-4 IR LED \$1.65  
MRD 14B photo darlington \$1.75  
MV 5026 Vis. LED \$1.65  
MT-2 PHOTO TRAS. \$1.90  
MCT-2 OPTO-ISOL. \$1.49  
MCD-2 OPTO-ISOL. \$1.49  
3/4" read switch 6/\$1.00  
1N4886 25-40W Power varactor \$4.95

**TRIACS**

PRV	1A	10A	15A	20A*
100	.40	.70	1.00	1.20
200	.70	1.10	1.50	1.60
300	.90	1.35	1.90	2.00
400	1.10	1.60	2.30	2.40
500	1.50	2.00	2.70	2.80

\*Press fit  
Terms: FOB Cambridge, Mass.  
Send check or Money Order. Include Postage. Average Wt. per package 1/2 lb. No. C.O.D.'s. Minimum Order \$3.00

### TRANSISTOR SPECIALS

2N965	PNP	6E	TO-18	.15W	7V	.1A	300MHZ	40Hte	5/\$1.00
2N1605	NPN	6E	TO-5	.15W	24V	.1A	14MHZ	125	5/\$1.00
2N2360	PNP	6E	TO-33	.06W	20V	.05A		980	32 \$5.50
2N5324	PNP	6E	TO-3	60W	250V	10A		20	35 \$1.50
2N1015D	NPN	SI	TO-82	150W	200V	7.5A		.025	10 \$1.45
2N2015	NPN	SI	TO-36	150W	50V	10A		.012	26 \$9.90
2N3584	NPN	SI	TO-66	35W	250V	2A		10	100 \$1.50
2N3055	NPN	SI	TO-3	115W	100V	15A		.01	50 \$1.00
2N3772	NPN	SI	TO-3	150W	60V	30A		.2	30 \$1.25
2N5296	NPN	SI	TO-220	36W	40V	4A		.8	60 \$5.50
2N6109	PNP	SI	TO-220	36W	40V	4A		.8	60 \$5.55
2N4898	PNP	SI	TO-66	25W	40V	4A		4	46 \$6.60
MJ2251	NPN	SI	TO-66	10W	225V	.5A		10	40 \$7.70
2N3638	PNP	SI	TO-5	.3W	25V	.5A		10	67 5/\$1.00

SV 1 Amp regulated power supplies. These units are similar to Analog Devices encapsulated SE 905 power supplies. \$34.95

DATA-LIT 707 Direct replacement for MAN-1 LED readouts \$3.95

MAN-3 LED READOUT \$2.95  
MAN-4 LED READOUTS \$3.95

8223 field prog. ROM \$8.00  
1101 256 bit RAM \$4.00  
8225 64 bit read-write RAM \$4.95

### Full Wave Bridges

PRV	2A	6A
200	.95	1.25
400	1.15	1.50
600	1.35	1.75

### DECADE COUNTER KIT

CONSISTING OF:  
1-NIXIE TUBE and SOCKET  
1-7490 1-7475 1-7441  
Special priced at \$5.95

**TTL IC SERIES**

7400	.30	7480	.65
7401	.30	7481	1.25
7403	.30	7483	1.25
7405	.35	7486	.60
7410	.30	7490	1.30
7411	.35	7492	1.00
7420	.30	7494	1.20
7430	.30	7495	.90
7440	.30	74107	.90
7441	1.50	74123	1.30
7442	1.50	74143	1.35
7446	1.50	74153	1.95
7447	1.50	74161	1.79
7448	1.50	74192	1.75
7450	.30	74193	1.75
7460	.30	74194	2.35
7472	.40	8570	1.90
7473	1.00	8590	1.90
7474	.50	9309	1.95
7475	1.00	9312	1.95
		9322	1.95

14 Pin DIP sockets \$1.50  
16 Pin DIP sockets \$1.60

**PRECISION TRIM POTS**  
500ohm, 10K, 20K, 25K  
50K \$1.75 3/\$2.00

**Silicon Power Rectifiers**

PRV	1A	3A	12A	50A
100	.06	.11	.24	.90
200	.07	.14	.35	1.25
400	.09	.20	.50	1.50
600	.11	.25	.70	1.80
800	.15	.30	.90	2.30
1000	.20	.35	1.10	2.75

### LINEAR CIRCUITS

PA234 1W audio amp \$1.25  
PA264-5 Watt regulator \$1.25  
LM309K 5V 1A regulator \$2.25  
531 High slew oper amp \$2.50  
536 FET input oper amp \$3.25  
537 Precision 741 \$2.50  
540 70W Power driver \$2.04  
555 2 us to 1 hour timer \$1.19  
560 phase lock loop \$3.25  
561 phase lock loop \$3.25  
565 phase lock loop \$3.35  
566 Function gen \$3.25  
567 Tone decoder \$3.25  
703 RF-IF amplifier \$1.80  
Dual 709 \$1.95  
709C operational Amp \$1.50  
723 Regulator \$1.75  
741 operational Amp \$1.50  
747 Dual 741 \$1.25  
TVR 2002 high power 723 \$1.00  
CA3065 FM/TV amp \$1.35  
5558 dual 741 \$1.88  
LM 308 oper amp \$2.95  
5556 oper amp \$1.75  
101 oper amp \$1.75  
741A oper amp \$1.60  
320 -5V reg. \$1.75  
320 -15V reg. \$1.75  
424 Zero volt switch \$1.25  
748 oper amp \$1.95

**Silicon Control Rectifiers**

PRV	6A	10A	20A	70A
100	.30	.45	1.00	3.50
200	.50	.75	1.25	6.50
300	.60	.90	1.50	
400	.70	1.10	1.75	9.50
500	.80	1.25	2.00	
600	.90	1.40	2.25	11.00

Send 20¢ for our latest catalog featuring Transistors and Rectifiers; 325 Elm St., Cambridge, Mass.

**OLID**

Post Office Box 74D

**TATE**

Somerville, Mass. 02143

**ALES**

Tel. (617) 547-4005



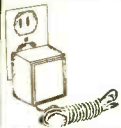

**D.C. POWER UNIT** \$2.95  
**TRANSFORMER & RECTIFIER**  
**IN A WALL PLUG**  
**U.L. LABELED**  
**8V DC - 4 WATT**

**XD 7-SEGMENT LED DISPLAY**  
**MINIATURE CALCULATOR SIZE—1/4"x7/32"**  
**LOWEST PRICE!**  
 W/O DEC. PT. \$2.50  
 WITH DEC. PT. \$2.75

**MAN-1**  
**7 SEGMENT LED DISPLAY** \$3.90

**MONSANTO MAN-2 LED 7 BY 5 ARRAY.** \$8.95  
**COMPLETE DATA FOR ASCII**  
**ALPHANUMERIC CIRCUITRY INCLUDED**  
**MAN-3M 7 SEGMENT LED** \$2.90  
**MAN-4 7 SEGMENT LED** \$3.75  
**8223 FIELD PROGRAMABLE ROM** \$7.50  
**256 BIT—32 8-BIT WORDS**  
**CUSTOM PROGRAMMING** \$5.00  
**PHASE LOCKED LOOPS 565 566 567** \$2.95  
**555 TIMER—WITH ALL DATA** \$1.05  
**LM309K REGULATOR** \$2.00

**LM 311 SUPER COMPARATOR** \$1.95  
**LM 308 ULTRA HI IMPED OP-AMP** \$1.95

**LM 1303 DUAL STEREO PREAMPLIFIER** \$1.95  
**LM 380 2-WATT AUDIO AMPLIFIER** \$1.75  
**CALCULATOR CHIP SPECIAL** \$8.95  
**DIGITAL CLOCK CHIP** \$12.50  
**6 DIGIT, 7 SEGMENT OUTPUT**  
**12 OR 24 HOUR, SINGLE POWER SUPPLY!**  
**WITH COMPLETE DATA**

**NATIONAL "DM" SERIES**

8090, 8091, 8092, 8093, 8094 \$ .85 8210,  
 8220 \$1.00 8601, 8820, 8830 \$ .95 8280 8281  
 \$1.10 8200, 8211, 8520, 8551 \$1.50 8570,  
 8590, 8880 \$1.75 8123, 8810, 8812 \$2.00

**LO-POWER TTL**

74L00, 74L02, 74L04, 74L10, 74L30, 74L51 \$ .40  
 74L72, 74L73, 74L74 \$ .75 74L90, 74L93 \$2.00  
 7400, 7401, 7402, 7403, 7404, 7405, 7408,  
 7410, 7420, 7430, 7440, 7453, 7454, 7460 \$ .24  
 7447, 7448, 7483, 7496 \$1.25  
 7475, 7490, 7492, 7493, 7495, \$ .90  
 74153, 74154, 74192, 74193 \$1.75

I.C.s SENT FIRST CLASS MAIL—WE PAY!

**JTM ASSOCIATES**

**P. O. BOX 843 MANCHESTER, MO. 63011**

Circle 78 on reader service card

# service notes

## USING DULL WIRE STRIPPERS

If your automatic strippers get dull and won't strip properly, simply squeeze the end of the wire being

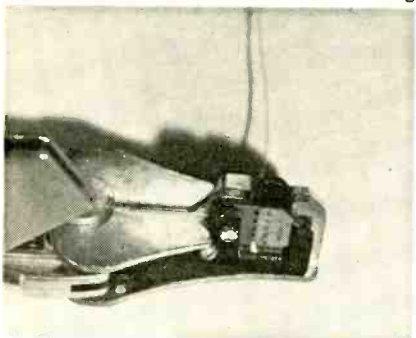

stripped with a pair of long-nose pliers. The wire will strip cleanly.—A. E. Plawcan

## FILING COMPONENTS

Knowing that you have a certain component is one thing—producing it is often something else again. One solution for all small axial-lead components that has proved its worth is

shown. Two widths (1/2" & 3/4") will handle all common components. The units are cut from filing card stock and punched for hanging.

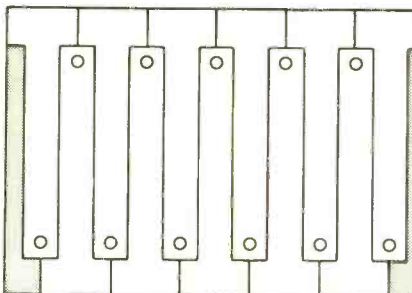
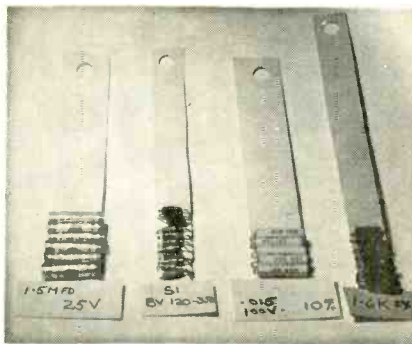

If lined stock is used the width of the stem of the "T" will be either 3 or 4 spaces and the units can easily be cut freehand as shown without any layout.—R. G. Cooper **R-E**

## REGULATED LABORATORY POWER SUPPLY

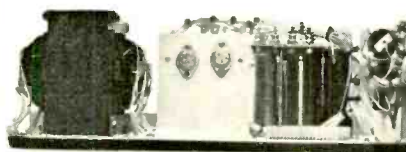

This computer power supply delivers 5 highly regulated & filtered voltages. 24 volts @ 1.6 amp, 26.5 volts @ 3.25 amp, 18 volts @ 2.6 amps, 14 volts @ 2.9 amp, & 12 volts @ 1 amp. Bench or 19" rack mount. A beautiful piece of equipment. 500 sold last year @ \$49.50.  
**STOCK NO. J5025 \$39.50**

## P & B POWER RELAY



Potter & Brumfield PR7AL1 DPST power relay. 25 amp silver contacts. 1 set auxiliary contacts, 5 amp. SPST. 115 volts 60 Hz. Removed from new equipment.

**STOCK NO. J9555 .75 ea. 3/2.00 5/3.00**

## POWER SUPPLY PC BOARD



This board has everything you need for a power supply up to 40 volts, 2 amps. You add the transformer for the voltage you want. Rectifier, filter, protective resistor and fuse holder, all on fiberglass board.

**STOCK NO. J9483 \$2.75 ea. 2/5.00**

Include sufficient postage, excess refunded. Send for new 48 page catalog, loaded with bargains. **MINIMUM ORDER \$3.00**

**DELTA ELECTRONICS CO.**  
**BOX 1, LYNN, MASSACHUSETTS 01903**  
 Phone (617) 388-4705

Circle 81 on reader service card

# IC PRICES SLASHED

## FACTORY FIRSTS

**NATIONALLY KNOWN BRANDS SATISFACTION GUARANTEED**



## DIGITAL TTL

ITEM	1-99	100-999	ITEM	1-99	100-999
7400N	32¢	28¢	7454N	32¢	28¢
7401N	32¢	28¢	7472N	39¢	35¢
7402N	32¢	28¢	7473N	48¢	43¢
7403N	32¢	28¢	7474N	48¢	43¢
7404N	35¢	31¢	7475N	80¢	68¢
7410N	32¢	28¢	7476N	56¢	50¢
7420N	32¢	28¢	7486N	56¢	50¢
7430N	32¢	28¢	7490N	85¢	70¢
7440N	32¢	28¢	7492N	85¢	70¢
7441N	\$1.50	\$1.35	7493N	85¢	70¢
7442N	\$1.20	\$1.07	7495N	\$1.20	\$1.08
7447N	\$1.15	\$1.03	74107N	54¢	49¢
7451N	32¢	28¢	74121N	60¢	51¢
7453N	32¢	28¢			

## LINEAR INTEGRATED CIRCUITS

709C MINIDIP	50¢	10/\$4.50	100/\$42.50
723C TO-5	\$1.00	10/\$9.00	100/\$85.00
741C MINIDIP	55¢	10/\$4.60	100/\$43.00
748C MINIDIP	60¢	10/\$5.50	100/\$51.00
558C MINIDIP	95¢	10/\$8.50	100/\$79.00
NE565A DIP	\$3.57	10/\$30.00	
LM309K TO-3	\$2.50	5/\$11.25	

The above full specification first line devices are also available with "relaxed specs", fully functional at discounts up to 50%. Mail reader service card for flyer.

## GENERAL PURPOSE SILICON TRANSISTORS

2N3638 PNP	20¢	10/\$1.65	100/\$15.00
2N3638A PNP	22¢	10/\$1.80	100/\$16.50
2N3641 NPN	23¢	10/\$2.00	100/\$17.50
2N3643 NPN	23¢	10/\$2.00	100/\$17.50
2N5133 NPN	15¢	10/\$1.25	100/\$10.00
2N5134 NPN	15¢	10/\$1.25	100/\$10.00
2N5137 NPN	18¢	10/\$1.50	100/\$13.65
2N5138 PNP	15¢	10/\$1.25	100/\$10.00
2N5139 PNP	15¢	10/\$1.25	100/\$10.00
2N3055 NPN	\$1	10/\$9.50	100/\$86.25

## 1 AMP SILICON RECTIFIERS

1N4001 50PIV	14¢/\$1	100/\$5	1M/\$42
1N4002 100PIV	14¢/\$1	100/\$5	1M/\$42
1N4003 200PIV	12¢/\$1	100/\$6	1M/\$45
1N4004 400PIV	11¢/\$1	100/\$7	1M/\$48
1N4005 600PIV	10¢/\$1	100/\$7	1M/\$55
1N4006 800PIV	8¢/\$1	100/\$8	1M/\$68
1N4007 1000PIV	7¢/\$1	100/\$9	1M/\$75

## SILICON SIGNAL DIODES

1N4148 (1N914 equiv.) 20¢/\$1 100/\$4 1M/\$30

## INTEGRATED CIRCUIT SOCKETS

14 PIN DIP SOLDER TYPE	45¢
16 PIN DIP SOLDER TYPE	50¢
14 PIN WIRE WRAP TYPE	55¢
16 PIN WIRE WRAP TYPE	60¢

## MOLEX IC SOCKET PINS

100/\$1.00 200/\$1.80 300/\$2.60 500/\$4.20  
 700/\$5.80 1000/\$8.20 ea add 1000/\$7.50

## DISPLAY DEVICES

5 VOLT 7 SEGMENT TUBE	\$3.75
DISPLAY KIT (TUBE+7447+7475+7490)	\$5.75
	3/\$16.50
7 SEGMENT LED (MAN-1 TYPE)	\$4.00
DISPLAY KIT (LED+7447+7475+7490+RESISTORS)	\$6.00
	3-/\$17.50

## 1/4 & 1/2 WATT 10% RESISTORS

1/4W 5¢ 30/\$1.20, 100/\$3.00, 500/\$13.75 as low as 1.7¢ ea in quantity—see catalog  
 1/2W 4¢ 30/90¢, 100/\$2.50, 500/\$11.25 as low as 1¢ ea in quantity—see catalog

COD orders accepted for same day shipment. Call 218 681 6674.

Free Catalog—Large Quantity Discounts—Orders Less Than \$10.00 Add 25¢—Others Postpaid

**DIGI-KEY** PRICE PACESETTER FOR QUALITY IC'S  
**BOX 126H THIEF RIVER FALLS, MN56701**

Circle 75 on reader service card  
 JULY 1973 • RADIO-ELECTRONICS

# LIVE IN THE WORLD OF TOMORROW...TODAY!

## A BETTER LIFE STARTS HERE

### 3-CHANNEL COLOR ORGAN KIT

Easy to build low-cost kit needs no technical knowledge. Completed unit has 3 bands of audio frequencies to modulate 3 independent strings of colored lamps (i.e. "lows"-reds, "middles"-greens, "highs"-blues. Just connect hi-fi, radio, power lamp etc. & plug ea. lamp string into own channel (max. 300w ea.). Kit features 3 neon indicators, color intensity controls, controlled Individ SCR circuits; isolation transformer; custom plastic housing; Instr.



Stock No. 41,831EH .....\$15.75 Ppd.



### TERRIFIC BUY IN HE-NE LASERS

Low price on 0.5mW Laser (random mode); 0.9mm beam dia. (at 10M, 16mm) belies its quality. New cold aluminum cathode tube for more life stability (hi beam: 9000-hr tube life under normal cond.) Ready to plug in, turn on. Starts instantly. Safe, easy for holography, interferometry, alignment. Metal case, 2.8 x 3.8 x 10", 110v AC. 633nm wavelength,

small beam divergence.

Stock No. 79,020EH .....\$88.50 Ppd.

0.7mW (SINGLE TEMOOODE), 0.8mm BEAM DIA.  
Stock No. 79,024EH .....\$99.50 Ppd.

### 130 EXPERIMENTS IN OPTICS . . .

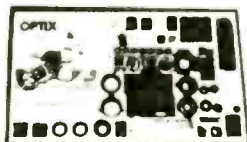

and photography! Optix® Experiments Kit is a complete optical & photography lab for 130 exciting experiments. Lets you recreate the periscope, telescope, microscope, kaleidoscope! . . . Build a 35mm reflex camera with interchangeable lens system! Make, develop photographic film! Enjoy the fun and fascination of having your own optics lab. Fully illustrated 112-pg. manual, 8½"x11", clearly explains usage of this stimulating kit's 114 precision engineered components.

Stock No. 71,646EH .....\$21.00 Ppd.

(And our FREE CATALOG is packed with exciting and unusual ecological & physical science items—plus 4,000 finds for fun, study or profit . . . for every member of the family.)

### NEW! ELECTRONIC DIGITAL COMPUTER KIT

Solve problems, play games, predict weather, even play miniature chess, with this actual working model of giant electronic brains. Amazing new fun way to learn all about computer programming . . . logic, decimal, binary systems, Laws of Sets. Even do your own programming after completing the simplified, 116-page instruction booklet. Circuits are easily changed, readout is from an illuminated control panel. Requires 2 "D" batteries (not incl.)

Stock No. 71,434EH . . .\$31.50 Ppd.  
(11 x 12½ x 4")



### 140 ELECTRICAL EXPERIMENTS! SEE FEATURE ARTICLE IN JUNE ISSUE!



Explore the fun world of electricity, magnetism, telecommunications. Exciting new Electrix™ Experiment Kit enables you to build a Morse code sender, receiving buzzer & printer; produce electricity with a real generator; assemble a working phone system; build an electric motor; 135 other projects. Illus. 112-pg. 8½ x 11" manual explains easy use of kit's 135 precision parts. Safety approved. Everything you need except 4 "C" cells.

Stock No. 71,647EH . . . \$17.95 Ppd.



### FEATHERWEIGHT TREASURE FINDER

Best, easiest to use solid state metal detector at its price. U.S. made! Only 3 lbs!! 6" search head detects penny at depth of 5", bag of coins at 18". Easily works thru dirt, sand, wood, water (30" deep) and rock with no power loss. "Sounds off" sharply with loudspeaker. Comes ready to go. Tuner control; 5 transistors; adjus. stem; perfect balance. Incls. 9v batt. FREE 101 TREASURE SITES GUIDE.

Stock No. 80,175EH .....\$39.95 Ppd.  
#80,181EH 10-TRANSISTOR MODEL .....\$71.00 Ppd.

### MAIL COUPON FOR GIANT FREE CATALOG!

164 PAGES • MORE THAN 4000 UNUSUAL BARGAINS!

Completely new Catalog. Packed with huge selection of telescopes, microscopes, binoculars, magnets, magnifiers, prisms, photo components, ecology and Unique Lighting items, parts, kits, accessories — many hard-to-get surplus bargains. 100's of charts, illustrations. For hobbyists, experimenters, schools, industry

EDMUND SCIENTIFIC CO.

300 Edscorp Building, Barrington, N. J. 08007

Please rush Free Giant Catalog "EH"

Name \_\_\_\_\_

Address \_\_\_\_\_

City \_\_\_\_\_

Zip \_\_\_\_\_

### COMPLETE & MAIL WITH CHECK OR M.O.

EDMUND SCIENTIFIC CO.

300 Edscorp Building, Barrington, N.J. 08007

How Many	Stock No.	Description	Price Each	Total

PLEASE SEND  GIANT FREE CATALOG "EH"

MERCHANDISE TOTAL \$

HANDLING CHARGE \$1.00\*

TOTAL \$

\*50¢ ON ORDERS OVER \$5.00

**30 DAY MONEY-BACK GUARANTEE**

YOU MUST BE SATISFIED OR RETURN ANY PURCHASE IN 30 DAYS FOR FULL REFUND

I enclose  check

money order for \$ \_\_\_\_\_

NAME \_\_\_\_\_

ADDRESS \_\_\_\_\_

CITY \_\_\_\_\_ STATE \_\_\_\_\_ ZIP \_\_\_\_\_

Circle 70 on reader service card



# '73 Heathkit® Catalog

Shown below are only a few of the more than 350 kits fully described in the 1973 Heathkit catalog. Kits for every interest, every budget... including color TV; stereo systems; electronic organs; marine equipment; a kitchen waste compactor; home intercoms and protection systems, garage door openers; table radios; portable radios and phonographs; guitar amplifiers and accessories; educational electronic workshops for youngsters and adults; tool sets; electronic test instruments; amateur and shortwave radio gear; radio-control equipment; metal locators.

Can you build a Heathkit? For 25 years people just like you have been doing it - armed with no more than a soldering iron and a few conventional hand tools.

No matter how complex the kit, the manual reduces assembly to a simple step-by-step operation. Add to that the availability of the technical correspondence department here in Benton Harbor, and service people in 36 retail stores across the country, and you see why we say "we won't let you fail." And finally, building a Heathkit is fun, pure and simple. The coupon below gets you started.

gets you started.

## Here are just a few of the new kits in this new '73 edition



Heathkit 50-watt Stereo Receiver. \$169.95\*



Heathkit VHF/FM Band-Scanning 8 channel Receiver. \$119.95\*



Heathkit Dolby Cassette Deck, Dolby Circuit. \$249.95\*



Heathkit 6-Digit Electronic Clock-Alarm. \$54.95\*

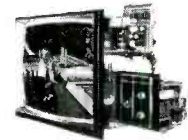

Heathkit 25V Solid-state Color TV with detent power tuning. \$599.95\*



NEW Heathkit Ultrasonic Intrusion Alarm. \$49.95\*

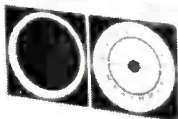

NEW Heathkit 8-transistor AM Radio for first-time kit-builders. \$14.95\*



Heathkit 2 1/2 Digit VOM. \$79.95\*



NEW Heathkit 8-digit pocket Calculator. \$92.50\*



NEW Heathkit 8-digit desktop Calculator. \$79.95\*



NEW Heathkit Small-engine Tune-up Meter for 2- and 4-cycles, all ignitions. \$39.95\*



NEW Heathkit 2-Meter Amateur Transceiver. \$179.95\*

## Send Today for Your Free '73 Heathkit Catalog

### HEATHKIT ELECTRONIC CENTERS

ARIZ.: Phoenix, 2727 W. Indian School Rd.; CALIF.: Anaheim, 330 E. Ball Rd.; El Cerrito, 6000 Potrero Ave.; Los Angeles, 2309 S. Flower St.; Pomona, 1555 Orange Grove Ave. N.; Redwood City, 2001 Middlefield Rd.; San Diego (La Mesa), 8363 Center Dr.; Woodland Hills, 22504 Ventura Blvd.; COLO.: Denver, 5940 W. 38th Ave.; CONN.: Hartford (Avon), 395 W. Main St. (Rte. 44); FLA.: Miami (Hialeah), 4705 W. 16th Ave.; GA.: Atlanta, 5285 Roswell Rd.; ILL.: Chicago, 3462-66 W. Devon Ave.; Downers Grove, 224 Ogden Ave.; IND.: Indianapolis, 2112 E. 62nd Ave.; KANSAS: Kansas City (Mission), 5960 Lamar Ave.; MD.: Baltimore, 1713 E. Joppa Rd.; Rockville, 5542 Nicholson Lane; MASS.: Boston (Wellesley), 165 Worcester St.; MICH.: Detroit, 18645 W. Eight Mile Rd. & 18149 E. Eight Mile Rd.; MINN.: Minneapolis (Hopkins), 101 Shady Oak Rd.; MO.: St. Louis, 9296 Gravois Ave.; N.J.: Fair Lawn, 35-07 Broadway (Rte. 4); N.Y.: Buffalo (Amherst), 3476 Sheridan Dr.; New York City, 35 W. 45th St.; Jericho, L.I., 15 Jericho Turnpike; Rochester, Long Ridge Plaza; OHIO: Cincinnati (Woodlawn), 10133 Springfield Pike; Cleveland, 5444 Pearl Rd.; PA.: Philadelphia, 6318 Roosevelt Blvd.; Pittsburgh, 3482 Wm. Penn Hwy.; TEXAS: Dallas, 2715 Ross Ave.; Houston, 3705 Westheimer; WASH.: Seattle, 221 Third Ave.; WIS.: Milwaukee, 5215 Fond du Lac.

HEATH	
Schlumberger	
HEATH COMPANY, Dept. 20-7 Benton Harbor, Michigan 49022	
<input type="checkbox"/> Please send FREE Heathkit Catalog.	
Name _____	
Address _____	
City _____	State _____ Zip _____
*Mail order prices; F.O.B. factory. CL-470	

Circle 100 on reader service card

# The all NEW

## TV TUNER SUBBER™

### Mark IV



Latest, all solid state version of the sensational signal circuit analyzing timesaver originated by Castle.

Invaluable for locating the break in the tuner and i.f. signal chain or analyzing agc system defects in tube TV receivers . . . essential for speedy location of signal circuit defects in modular IC, solid state and hybrid TV receivers.

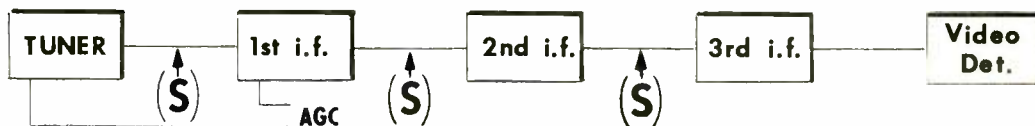

Subber Mk. IV permits injection of substitute 40MHz signal at points (S) in signal amplifier chain. Permits signal injection after the agc controlled stages to simplify testing for agc defects.

- Works with any 40MHz receiver . . . color or black and white . . . solid state, tube or hybrid.
- High level, low impedance output furnishes signal usable at input of final i.f. stage.
- Special output circuit works equally well into first i.f. input of late model, link coupled systems and older, low "C" bandpass coupled systems.
- Antenna input and i.f. output electrically isolated; no "hot" chassis hazards.
- No need to disconnect supply leads from suspected tuner being tested. Substitutes the VHF tuner and tests the UHF tuner.
- Tunes all 12 VHF channels, has preset (memory) fine tuning on all channels.
- Higher overall gain than previous models with wide range gain reduction control of 60db.
- Completely self contained and battery operated, uses popular batteries available everywhere. Simple battery replacement; battery compartment in rear of custom molded case.
- Reduced current consumption extends battery life to as much as double that of previous models. Bright LED indicator warns when unit is ON.
- Use on the bench or in the home . . . anywhere.
- Comes complete with extension cables, batteries and instructions.

**TV TUNER SUBBER™ Mark IV net \$45.95**

Contact your distributor.

Include \$1.50 shipping and handling on prepaid mail orders: we will ship C.O.D.



**CASTLE TV TUNER SERVICE, INC.**

5715 N. Western Ave., Chicago, Illinois 60645 • Phone: (312) - 561-6354

In Canada: Len Finkler Co., Ontario

Circle 71 on reader service card